

PW2 SERIES

4 to 20 mA, 2-Wire Device



PW2xxxS



PW2xxxBP

The PW2 Series 2-wire, 4 to 20 mA wet pressure transducers incorporate microprocessor profiled sensors for exceptional accuracy and reliability. Easy to use and designed to provide exceptional installation savings, the PW2 Series is ideal for measuring pressure across pumps, filters, heat exchangers, compressors, and other non-corrosive wet media applications.

The optional pre-assembled bypass valve is designed for easy maintenance and a one-step installation.

SPECIFICATIONS

GENERAL

Input Power	Class 2; 12 to 24 Vdc, loop powered (polarity insensitive)
Maximum Current Draw	29 mA
Output	2-wire transmitter; user selectable 4 to 20 mA (clipped & capped)*
Surge Damping	Electronic; 5-second averaging
Zero Adjust	Pushbutton auto-zero terminals
Housing Material	White powder-coated aluminum

PRESSURE RANGES (SELECTABLE)

0 to 50 psi (0 to 3.45 barg) (Gauge)	0-5/10/25/50 psid (0-0.34/0.69/1.72/3.45 bard) (Differential)
0 to 100 psig (0 to 6.89 barg) (Gauge)	0-10/20/50/100 psid (Differential) (0-0.69/1.38/3.45/6.89 bard) (Differential)
0 to 250 psi (0 to 17.24 bar) (Gauge)	0-25/50/125/250 psid (Differential) (0-1.72/3.45/8.62/17.24 bard) (Differential)

SENSOR

Accuracy @ 25 °C**	Range A, B, C: ±1% F.S.; Range D: ±2% F.S.***
Media Compatibility	Media compatible with 17-4 PH stainless steel
Long Term Stability	±0.25% per year
Proof Pressure	Max. 2x F.S. range
Burst Pressure	Max. 5x F.S. range
Temperature Compensated Range	0 to 50 °C (32 to 122 °F); TC Zero <±1.5% of product F.S. per sensor; TC Span <±1.5% of product F.S. per sensor, (2 sensors per unit)
Media Temperature Limits	-20 to 85 °C (-4 to 185 °F); 0 to 90% RH non-condensing

Jumper selectable Dual sensor

The jumper-selectable output switch for normal (4 to 20 mA) or reverse (20 to 4 mA) operation provides application flexibility

Dual sensor design for improved overpressure tolerance... eliminates the requirement for a bypass valve assembly in most applications

Rugged

Rugged, die-cast enclosure provides NEMA 4 sealing

High stability

Jumper-controlled electronic surge dampening for high stability

Selectable

Selectable differential units: psid or bard

Zero calibration

Pushbutton zero calibration – no trim pots to adjust... maintain accuracy and reduce callbacks with automatic zero calibration

APPLICATIONS

- Monitoring and controlling pump differential pressure
- Chiller/boiler differential pressure drop
- CW/HW system differential pressure

Product Operating Environment	-10 to 55 °C (14 to 130 °F); 0 to 90% RH non-condensing
-------------------------------	---

WARRANTY

Limited Warranty	5 years
------------------	---------

AGENCY APPROVALS



* Minimum input voltage: 250 Ω loop = 12 Vdc; 500 Ω loop = 17 Vdc

**Accuracy combines linearity, hysteresis, and repeatability.

***FS is defined as full span of selected range in bi-directional mode.

EMC Conformance - Low voltage directive 2014/35/EU; EMC directive 2014/30/EU.

EMC Special Note: Connect this product to a DC distribution network or an AC/DC power adaptor with proper surge protection (EN 61000-6-1 specification requirements).

MICROPROCESSOR PROVIDES DIGITAL SIGNAL CONDITIONING

- Noise rejection reduces fluctuating readings due to noise or turbulence
- Surge damping prevents false alarms by averaging fast peaks

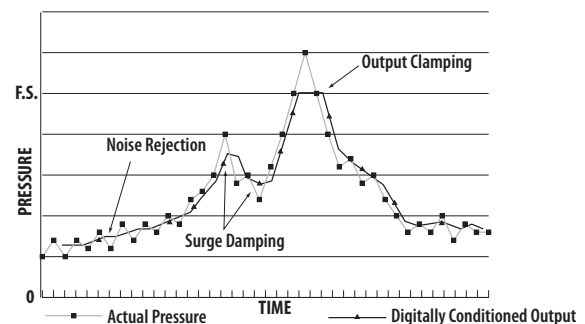

WIRING DIAGRAM

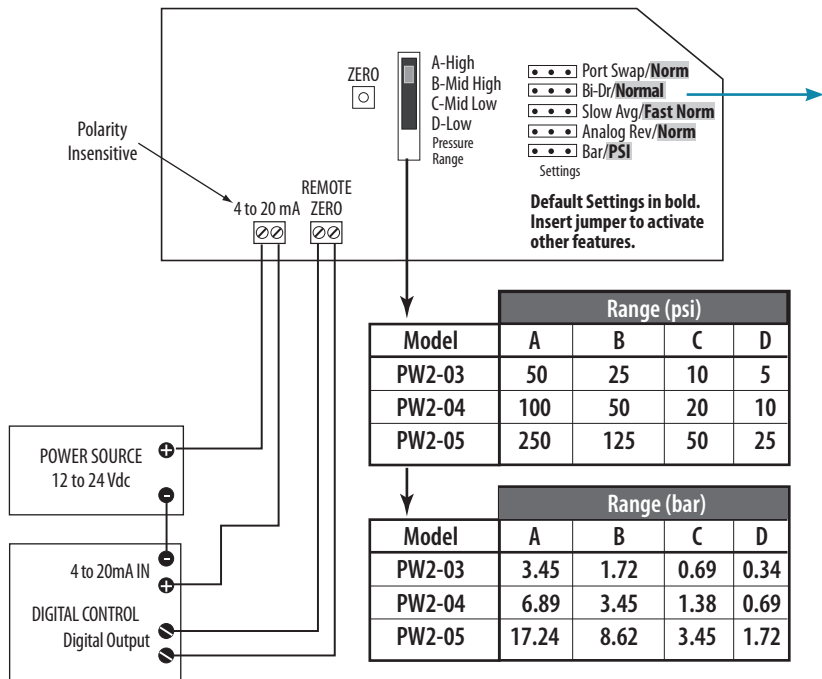

Bidirectional Operation

Input Conditions		Result	Outputs Read
HI PORT	LO PORT	DP	4-20mA
100 psi	0 psi	+100 psi	20mA
100 psi	50 psi	+50 psi	16mA
50 psi	50 psi	0 psi	12mA
50 psi	100 psi	-50 psi	8mA
0 psi	100 psi	-100 psi	4mA

Model	Range (psi)			
	A	B	C	D
PW2-03	50	25	10	5
PW2-04	100	50	20	10
PW2-05	250	125	50	25

Model	Range (bar)			
	A	B	C	D
PW2-03	3.45	1.72	0.69	0.34
PW2-04	6.89	3.45	1.38	0.69
PW2-05	17.24	8.62	3.45	1.72

DIMENSIONAL DRAWING

PW2xxxS

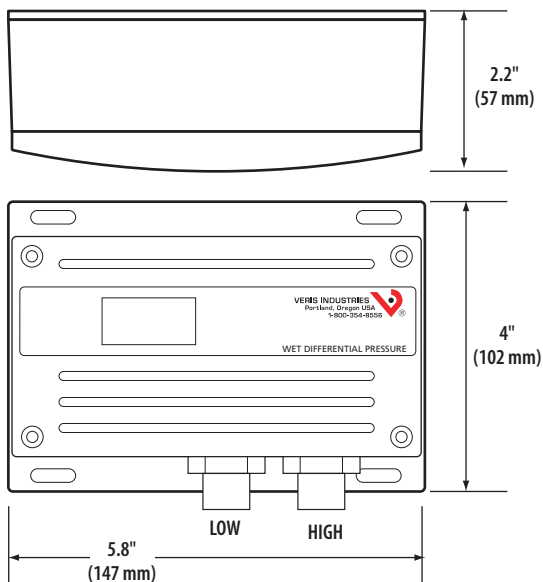

DIMENSIONAL DRAWING

PW2xxxBP

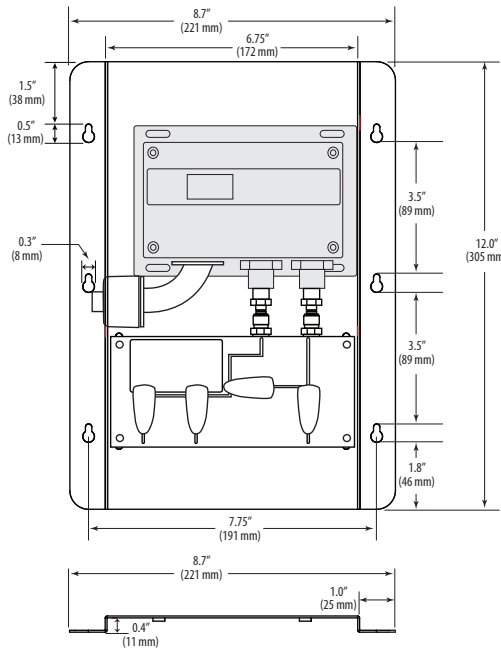

ORDERING INFORMATION

Local Display	NIST	Operational Range*	Options
PW2 <input type="checkbox"/>	<input type="checkbox"/>	<input type="checkbox"/>	<input type="checkbox"/>
L = LCD Display X = No Display	N = NIST X = None	03 = 0 to 50 psig/3.45 barg 04 = 0 to 100 psig/6.89 barg 05 = 0 to 250 psig/17.24 barg	S = Standard BP = With mounted bypass assembly

Example: PW2 L X 04 S

*Select operational range according to maximum gauge pressure, NOT differential pressure.
Example: High gauge pressure=90 psig, Select 100 psig model (04).

