

OpenAir® Electronic Damper Actuators GDE/GLB Enhanced Rotary Non-spring Return

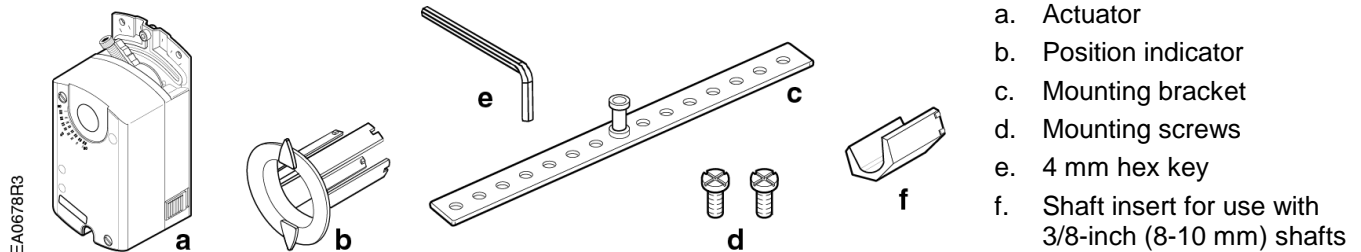

Figure 1. Parts of the GDE/GLB Enhanced Rotary Actuator.

Product Description

Steps for direct-coupled mounting of the OpenAir GDE and GLB Enhanced Series non-spring return rotary electronic damper actuators.

Product Numbers

GDE141.1U	GLB141.1P
GDE141.1U/B (24 pk)	GLB141.1Q
GDE141.1P	GLB146.1P
GDE141.1P/B (24 pk)	GLB161.1P
GDE141.1Q	GLB161.1Q
GDE142.1P	GLB166.1P
GDE146.1P	GLB341.1U
GDE161.1P	GLB346.1U
GDE161.1P/B (24 pk)	
GDE161.1Q	
GDE163.1P	
GDE164.1P	
GDE166.1P	
GDE341.1U	
GDE346.1U	

Required Tools

- 4 mm hex key (included)
- 4 mm (5/32-inch) drill bit and drill
- Small flat-blade screwdriver
- Marker or pencil

Estimated Installation Time

30 minutes

Warning/Caution Notations

WARNING:		Personal injury/loss of life may occur if you do not follow a procedure as specified.
CAUTION:		Equipment damage or loss of data may occur if you do not follow a procedure as specified.

Instructions



WARNING:

Do not open the actuator.

NOTE: Place the actuator on the damper shaft so that the front of the actuator is accessible. The label is on the front side.

1. Determine whether the damper blades will rotate clockwise or counterclockwise to open. See Figure 12 and Figure 13.
2. If the blades will rotate counterclockwise, slide the manual override switch to manual, and move the adjustment lever to the right. Return the switch to automatic. See Figure 9.

Mounting and Installation

Mounting Orientation

UL NEMA Type 2 and IP54 approved in all positions except as shown below:



Figure 2. Unapproved Position for UL NEMA Type 2 and IP54.

NOTE: The GDE/GLB Enhanced actuator comes with a factory-installed 1/2-inch shaft guide. If the shaft size is 1/2-inch, proceed with Figure 6.

When using a 3/8-inch shaft: Remove factory-installed 1/2-inch guide. See Figure 3.

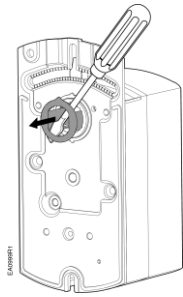

Figure 3. Removing 1/2-inch Ø Shaft Guide for 3/8-in or 5/8-in Shaft.

When using a 5/8-inch shaft:

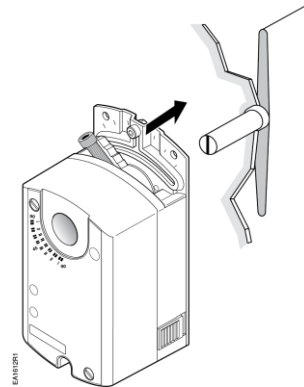

Figure 5. 5/8-inch Ø Shaft.

1. Remove factory-installed 1/2-inch guide. See Figure 3.
2. Mount actuator to shaft per Figure 6.

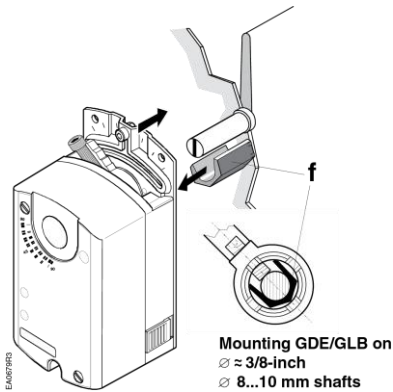

Figure 4. 3/8-inch Ø Shaft, See Figure 1 Item f.

1. A 3/8-inch shaft adapter is provided in actuator package.
2. Hold the shaft insert so that the raised tabs are inserted last when placing the insert into the back of the actuator.
3. Proceed to Figure 6.

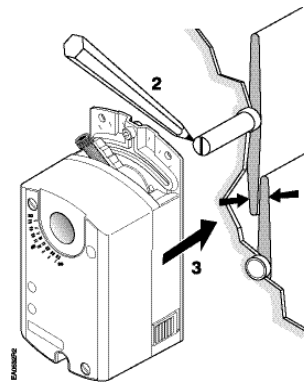

Figure 6. Mounting Actuator to Damper Shaft.

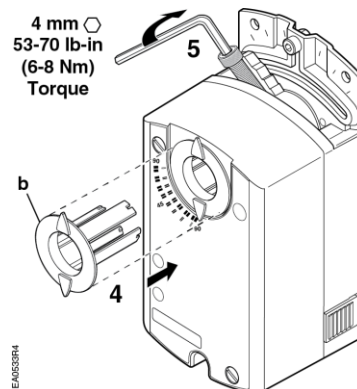

Figure 7. Installing the Position Indicator (b).

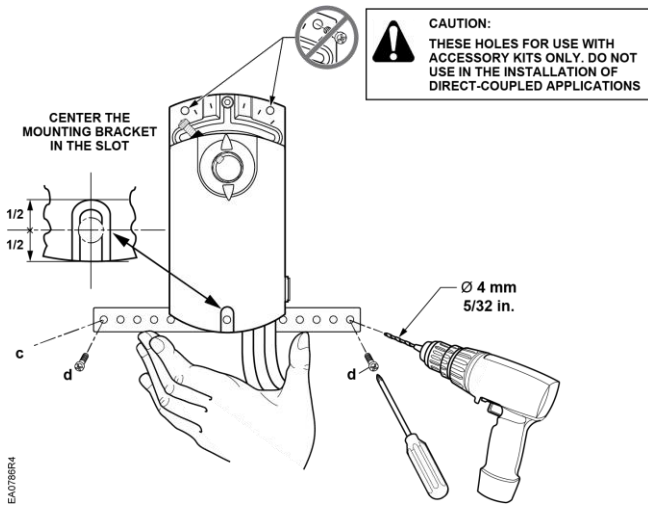

Figure 8. Attaching the Mounting Bracket.

Manual Override

To move the damper blades and lock the position with no power present, do the following:

1. Slide the red manual override knob toward the back of the actuator. See Figure 9.
2. Make adjustments to the damper position.
3. Slide the red manual override knob toward the front of the actuator.

Once power is restored, the actuator returns to automated control.

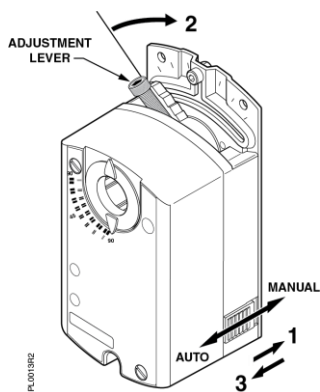

Figure 9. Manual Override.

Dual Auxiliary Switch Setting For GDE/GLB146/346, GDE164 and GDE/GLB166 only.

Factory setting: A = 5° B = 85°

Use a flat-blade screwdriver to adjust the A switch. The long arm of the † points to the setting. Manually turn the red ring of the B switch. The narrower tab on the ring points to the setting. See Figure 10.

The auxiliary switch setting shafts rotate with the actuator.

NOTE: The scale is valid only when the actuator is in the 0 position on clockwise motion.

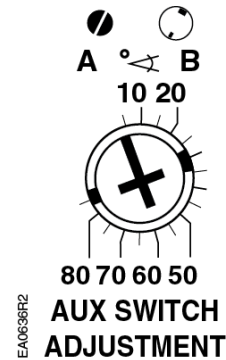

Figure 10. Auxiliary Switch Setting Dial.

Mechanical Range Adjustment

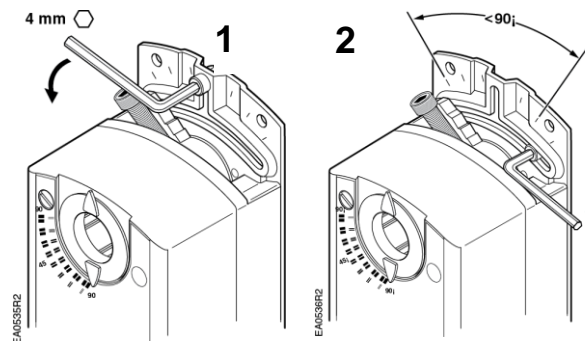

Figure 11. Moving the Mechanical Range Stop.

1. Loosen the stop set screw.
2. Move it along the track to the desired position, and fasten it in place using maximum 26 to 44 lb-in (3 to 5 Nm) torque.

Changing Rotation Direction DIP Switch Settings

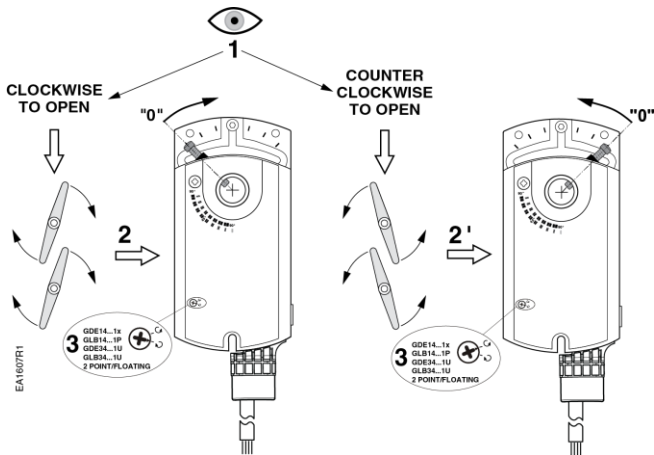

Figure 12. Setting the Direction of Rotation, 2-Position/Floating.

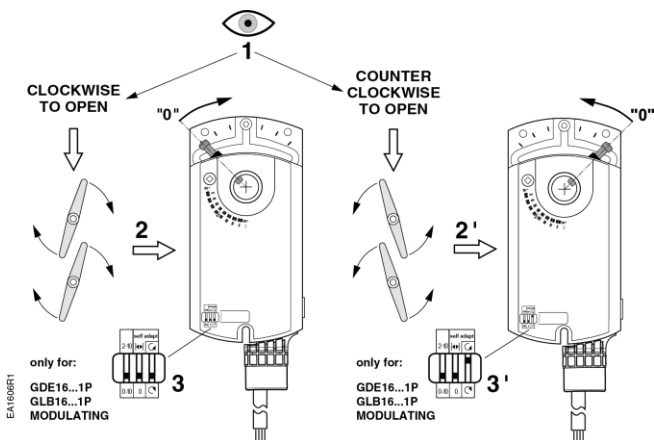

Figure 13. Setting the Direction of Rotation, Modulating Actuator.

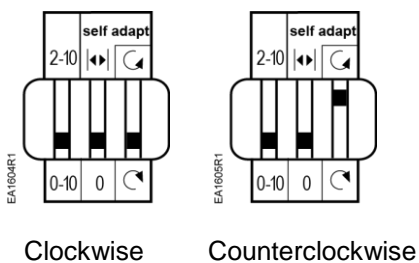



Figure 14. Rotation Direction, Modulating Actuator.

NOTE: For DIP switch setting options, see the Technical Instructions listed in *References*.

Mechanical Range Limitation and Self-adapt Feature

- To use the entire 0(2) to 10V input signal to control the adjusted range, raise the tab located on the lower left-hand side of the actuator and locate the DIP switches. See Figure 15.
- Set the self-adapt DIP switch (middle) to  (ON).

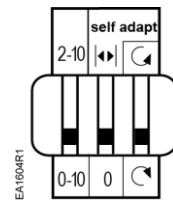

Figure 15. Self-adapt Switch in OFF Position (Factory Setting).

- Close the tab over the DIP switches.

For example, if you set the locking screw at 70° and turn the self-adapt switch ON, a 5V input signal will drive the damper to 35° (50% of its adjusted range).



CAUTION:

When turning the self-adaptive feature on, or after software reset with the feature on, the actuator will enter a five-minute calibration cycle as the actuator adjusts to the rotation limits of the system. The software reset happens after power on, or may be caused by electrostatic discharge (ESD) at levels of 2 kV and above.

Slope (Span) and Offset Adjustment

For GDE163x and GDE164x only

Factory setting:
 Slope (span) $\Delta U \approx 10$
 Offset $U_0 = 0$



Use a flat-blade screwdriver to make adjustments. The long arm of the  points to the setting.



OFFSET, U_0



Figure 16.

Wiring

All wiring must conform to NEC and local codes and regulations.

Use earth ground isolating step-down Class 2 transformers. Do not use autotransformers.

Determine the supply transformer rating by summing total VA of all actuators used. It is recommended that one transformer power no more than 10 actuators.



WARNING:

Installations requiring **CE** Conformance

- All wiring for CE rated actuators must only be separated extra low voltage (SELV) or protective extra low voltage (PELV) per HD384-4-41.

- Use safety-isolating transformers (Class III transformer) per EN 61558. They must be rated for 100% duty cycle.
- Overcurrent protection for supply lines is maximum 10A.

Wiring Diagrams



CAUTION:

Do not wire different types of actuators (such as GBB or GIB Actuators) in parallel with these models.

GDE/GLB14

Each wire has the standard symbol printed on it. See Table 1.

24 Vac/dc Power Supply 2-Point/Floating Control.

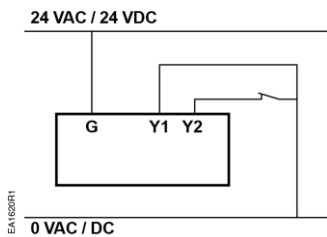
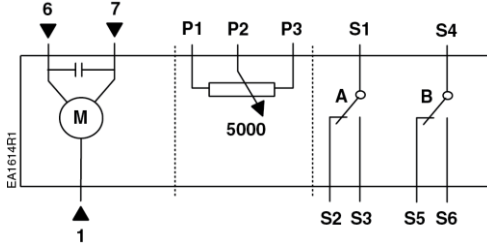

Figure 17. 2-Position, SPST (Single-Pole, Single-Throw).

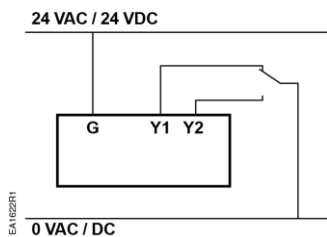

Figure 18. 2-Position, SPDT (Single-Pole, Double-Throw).

Table 1. 2-Point/Floating Control 24 Vac/dc.

Standard Symbol	Function	Terminal Designation	Color
1	Supply (SP)	G	Red
6	Control signal clockwise	Y1	Violet
7	Control signal counterclockwise	Y2	Orange
Factory-Installed Options			
S1	Switch A Common	Q11	Gray/red
S2	Switch A N.C.	Q12	Gray/blue
S3	Switch A N.O.	Q14	Gray/pink
S4	Switch B Common	Q21	Black/red
S5	Switch B N.C.	Q22	Black/blue
S6	Switch B N.O.	Q24	Black/pink
For GDE14 Models Only			
P1	Feedback Potentiometer 0 to 100% P1 - P2 (0 to 5,000 ohms)	a	Black
P2	Feedback Potentiometer Common	b	Black
P3	Feedback Potentiometer 100 to 0% P3 - P2 (5,000 to 0 ohms)	c	Black

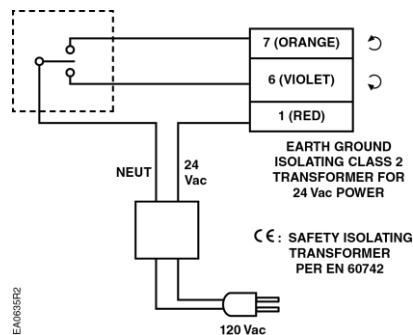

Figure 19. Floating Control, 24 Vac/dc.

GDE/GLB34x

100 to 240 Vac Power Supply, Two-Point Floating Control

Each wire has the standard symbol printed on it. See Table 2.

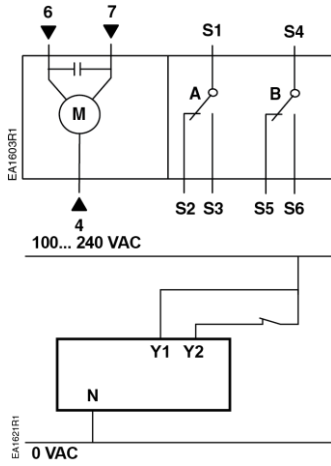

Figure 20. 2-Position, SPST (Single-Pole, Single-Throw).

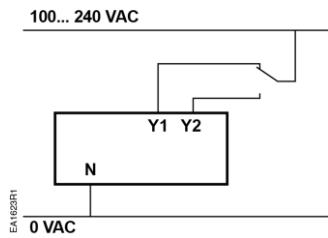

Figure 21. 2-Position, SPDT (Single-Pole, Double-Throw).

GDE/GLB16x

24 Vac/dc Power Supply, Modulating Control

Each wire has the standard symbol printed on it. See Table 3.

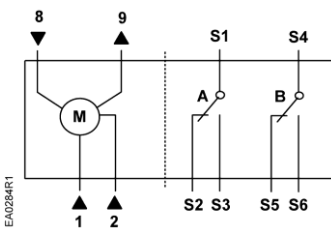

Figure 22. 0(2) to 10 Vdc Modulating Control.

Table 2. Two-Point, Floating Control, 100 to 240 Vac.

Standard Symbol	Function	Terminal Designation	Color
4	Supply (SP)	N	Light Blue
6	Control signal clockwise	Y1	Black
7	Control signal counterclockwise	Y2	White

Factory-Installed Options.

S1	Switch A – Common	Q11	Gray/red
S2	Switch A – N.C.	Q12	Gray/blue
S3	Switch A – N.O.	Q14	Gray/pink
S4	Switch B – Common	Q21	Black/red
S5	Switch B – N.C.	Q22	Black/blue
S6	Switch B – N.O.	Q24	Black/pink

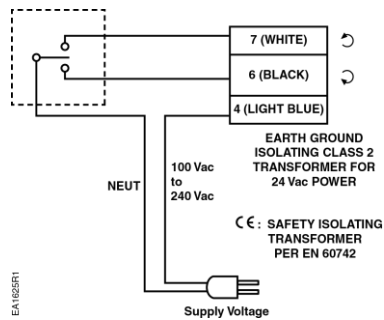

Figure 23. Floating Control, 100 to 240 Vac.

Table 3. Modulating Control.

Standard Symbol	Function	Terminal Designation	Color
1	Supply (SP)	G	Red
2	Neutral (SN)	G0	Black
8	0(2) to 10V input signal	Y	Gray
9	Output for 0(2) to 10 Vdc position indication	U	Pink

Factory-Installed Options.

S1	Switch A – Common	Q11	Gray/red
S2	Switch A – N.C.	Q12	Gray/blue
S3	Switch A – N.O.	Q14	Gray/pink
S4	Switch B – Common	Q21	Black/red
S5	Switch B – N.C.	Q22	Black/blue
S6	Switch B – N.O.	Q24	Black/pink

Retrofit Wiring

Modulating Control (0 to 10 Vdc)	Siemens GDE Series GLB Series		Belimo LMB Series NMB Series		Honeywell MN7505 Series MN7510 Series*		Johnson M9104 Series M9109 Series*	
	Color	Number	Color	Number	Color	Number	Color	Number
Supply 24V	Red	1	Red	2	Red	1	Red	2
Common	Black	2	Black	1	Black	2	Black	1
0(2) to 10 Vdc Input	Gray	8	White	3	Brown	3	Gray	3
0(2) to 10 Vdc Feedback	Pink	9	Orange	5	Blue	5	Orange	4

NOTE: MN7510 Series is not available pre-cabled. Numbers listed associate with terminal positions.
 M9109 Series is not available pre-cabled. Numbers listed associate with terminal positions.

Floating Control	Siemens GDE Series GLB Series		Belimo LMB Series NMB Series		Honeywell MN6105 Series MN6110 Series*		Johnson M9104 Series M9109 Series*	
	Color	Number	Color	Number	Color	Number	Color	Number
Common	Red	1	Black	1	Black	2	Black	1
24V CW	Violet	6	Red	2	Red	3	Red	2
24V CCW	Orange	7	White	3	White	4	Orange	3

NOTE: MN6110 Series is not available pre-cabled. Numbers listed associate with terminal positions.
 M9109 Series is not available pre-cabled. Numbers listed associate with terminal positions.

References

OpenAir® Electronic Damper Actuators 155-784
 GDE Series Enhanced Non-spring Return Rotary
 Technical Instructions

OpenAir® Electronic Damper Actuators 155-785
 GLB Series Enhanced Non-spring Return Rotary
 Technical Instructions

Dimensions

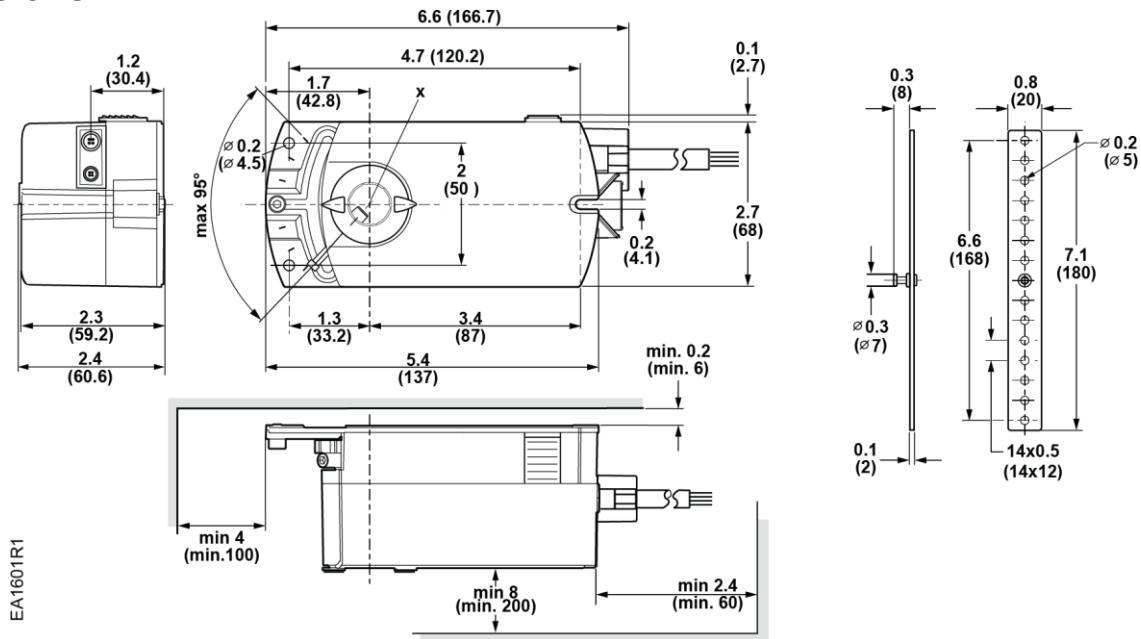

Figure 24. Dimensions of the OpenAir GDE/GLB Enhanced Actuator and Mounting Bracket.

Information in this publication is based on current specifications. The company reserves the right to make changes in specifications and models as design improvements are introduced. OpenAir is a registered trademark of Siemens Industry, Inc. Product or company names mentioned herein may be the trademarks of their respective owners. © 2016 Siemens Industry, Inc.