

## Q-Series Outdoor Air Relative Humidity and Relative Humidity & Temperature Sensors

### Product Description

The Q-Series Outdoor Air Relative Humidity, and Relative Humidity & Temperature Sensors monitor and transmit changes in humidity and temperature to the building control systems. These units are especially suited for applications where precise, stable humidity sensing is required. Standard models available are 2% and 2% certified, for both humidity only and combination humidity with temperature sensing. Sensors are offered with either 4 to 20 mA or 0 to 10 Volt output signals.

### Product Numbers

Part Number	Description
QFA3100	Outdoor air humidity sensor (2%), 0 to 10 Vdc
QFA3101	Outdoor air humidity sensor (2%), 4 to 20 mA
QFA3160	Outdoor air humidity sensor (2%), 0 to 10 Vdc/Temp 0 to 10 Vdc
QFA3160D	Outdoor air humidity sensor (2%), 0 to 10 Vdc/Temp 0 to 10 Vdc with display
QFA3171	Outdoor air humidity sensor (2%), 4 to 20 mA/Temp 4 to 20 mA
QFA3171D	Outdoor air humidity sensor (2%), 4 to 20 mA/Temp 4 to 20 mA with display
QFA4171	Outdoor air humidity sensor (2%), 4 to 20 mA/Temp 4 to 20 mA, certified
QFA4171D	Outdoor air humidity sensor (2%), 4 to 20 mA/Temp 4 to 20 mA, certified with display
QFA4160	Outdoor air humidity sensor (2%), 0 to 10 Vdc/Temp 0 to 10 Vdc, certified
QFA4160D	Outdoor air humidity sensor (2%), 0 to 10 Vdc/Temp 0 to 10 Vdc, certified with display
<b>Accessories</b>	
AQF3101	Sensor filter cap
AQF4150	Replaceable, certified sensor tip
AQF3100	Sun shield
74 662 0104 0	US 1/2-inch rigid conduit adapter

### Required Tools

- Phillips screwdrivers, sizes No. 1 and No. 2
- Medium flat-blade screwdriver
- Wire cutters/strippers
- Tape measure
- Medium-duty electric drill
- Drill bit for wall anchor hole
- Marker or pencil
- Two No. 10 screws and wall anchors

### Expected Installation Time

30 minutes

### Prerequisites

- Ensure that the appropriate field wiring is installed.  
Appropriate wiring is one or more twisted pair or three conductor cables (plenum or non-plenum as required) within the maximum wiring run length for the humidity/temperature controller. The maximum recommended length is 750 feet (229 m).
- Ensure that all wiring complies with National Electric Code (NEC) and local regulations.

### Installation

1. Determine where the sensor is to be located and install the Sun Shield, AQF3100, as shown in Figure 1. The installation surface determines which mounting components are to be used.

**NOTE:** The shield must be mounted vertically as shown in Figure 1.

2. Remove sensor cover and install plug in knockout next to sensing probe. See Figure 1 (2).
3. Pull the field wiring through the conduit and into the sensor base. See Figure 2.

4. Connect the field wiring to the sensor terminal block on the base. See Figures 3 and 4 for wiring diagrams.

5. Install the sensor onto the Shield as shown. See Figure 1 (7).

The installation is now complete.

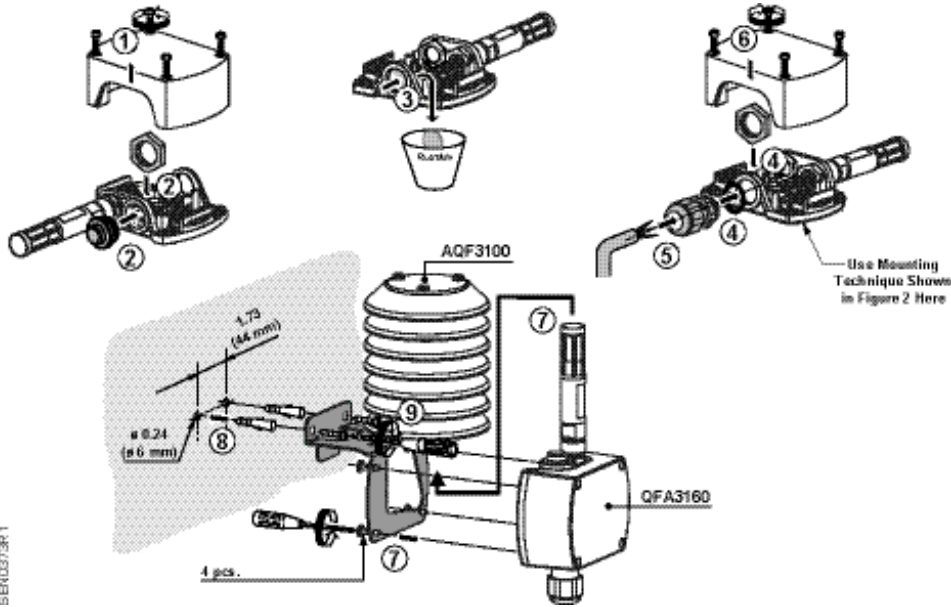

Figure 1. Rh/T Outdoor Air Sensor Installation.

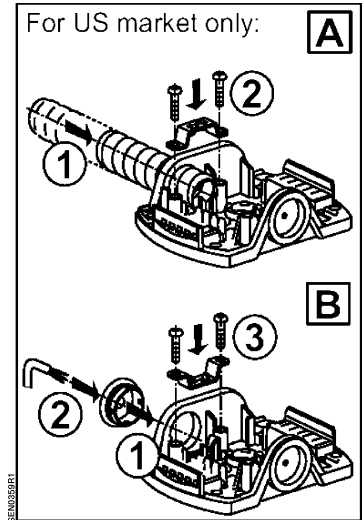

Figure 2. Field Wiring.

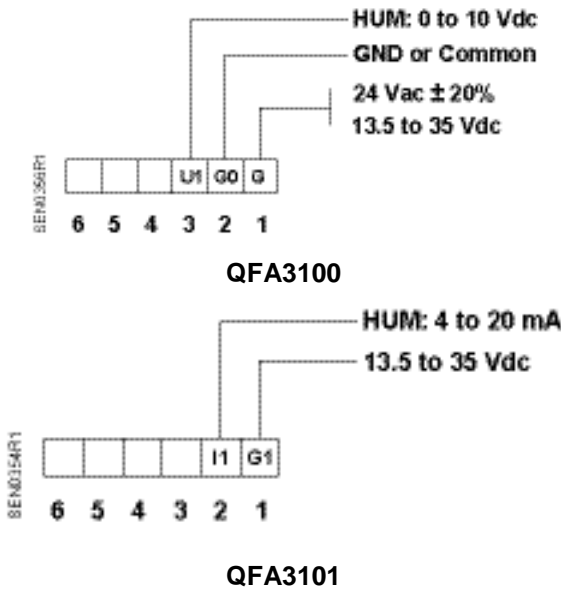

Figure 3. Wiring Diagrams for RH Sensors.

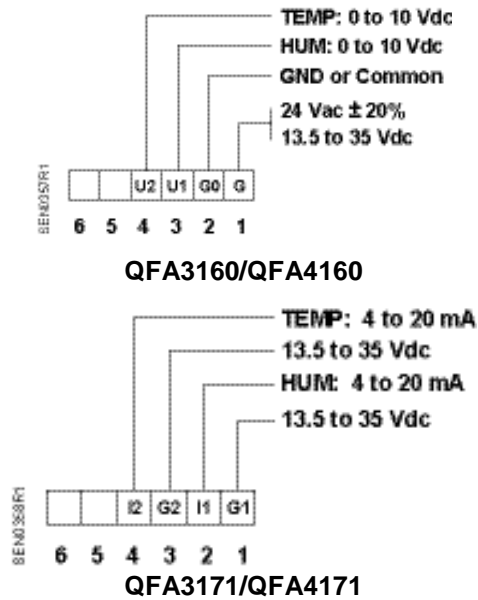

Figure 4. Wiring Diagrams for RHT Sensors.

Information in this publication is based on current specifications. The company reserves the right to make changes in specifications and models as design improvements are introduced. Product or company names mentioned herein may be the trademarks of their respective owners. © 2009 Siemens Industry, Inc.