

Catalog Number • Numéro de Catalogue • Número de Catálogo: LMRC-221

Country of Origin: Made in China • Pays d'origine: Fabriqué en Chine • País de origen: Hecho en China

LMRC-221-U is BAA and TAA compliant (Product produced in the U.S.)



SPECIFICATIONS

Input Voltage	120/277VAC, 50/60Hz
Minimum Load Rating	10 watt
Maximum Load Ratings	
Incandescent, Quartz Halogen, LED Drivers*	
Magnetic Low Voltage* Transformer (MLV).....	20A
Electronic Low Voltage* Transformer (ELV).....	20A
Electronic Fluorescent Dimming Ballasts:	
2 Wire Advance® Mark X or equal	
3 Wire Lutron® Hi-Lume or Eco-10	
Neon/Cold Cathode (cc).....	1920 W @ 120 V
.....	4432 W @ 277 V

* Forward Phase compatible, dimming rated only

Output to DLM Local Network	up to 250mA @ 24VDC
Connection to the DLM Local Network.....	4 RJ-45 ports
DLM Local Network characteristics when using LMRC-11x/2xx room controllers:	
Low voltage power provided over Cat 5e cable (LMRJ);	
max current 800mA. Supports up to 64 load addresses,	
48 communicating devices including up to 4 LMRC-10x	
series and/or LMPL-101 controllers.	
Free topology up to 1,000' max.	
Environment	For Indoor Use Only
Operating Temperature	32° to 131°F (0° to 55°C)
Storage Temperature	23° to 176°F (-5° to 80°C)
Relative Humidity	5 to 95% (non condensing)
Max Branch Circuit Overcurrent Protection.....	25A
Patent Pending	

This unit is pre-set for Plug n' Go™ operation, adjustment is optional.

For full operational details, adjustment and more features of the product, see the DLM System Installation Guide provided with Wattstopper room controllers, and also available at www.legrand.us/wattstopper.

Installation shall be in accordance with all applicable regulations, local and NEC codes. Wire connections shall be rated suitable for the wire size (lead and building wiring) employed. For Class 2 DLM devices and device wiring: To be connected to a Class 2 power source only. Do not reclassify and install as Class 1, or Power and Lighting Wiring.

PLACEMENT EXAMPLE

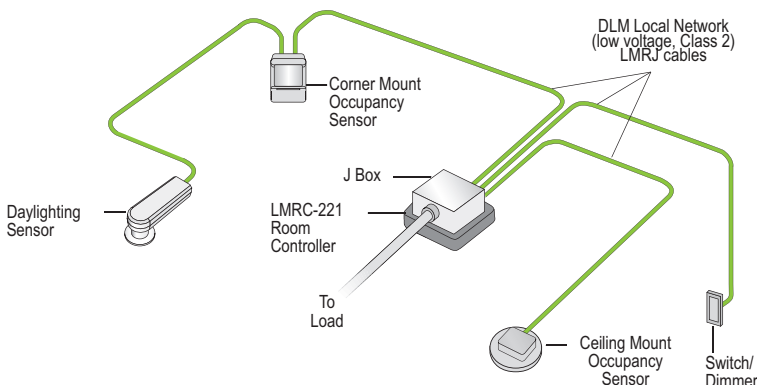

WARNING: TURN THE POWER OFF AT THE CIRCUIT BREAKER BEFORE WIRING.

CAUTION: TO CONNECT A COMPUTER TO THE DLM LOCAL NETWORK USE THE LMCI-100. NEVER CONNECT THE DLM LOCAL NETWORK TO AN ETHERNET PORT – IT MAY DAMAGE COMPUTERS AND OTHER CONNECTED EQUIPMENT.

MOUNTING THE CONTROLLER

The room controller mounts to a four square deep junction box using the included mounting plate with the hinge pins extending away from the box as shown.

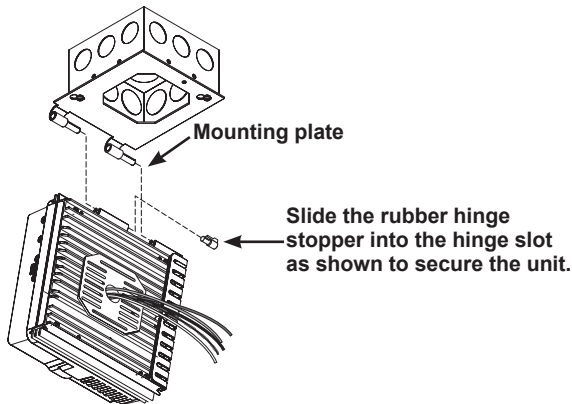

LINE VOLTAGE WIRING

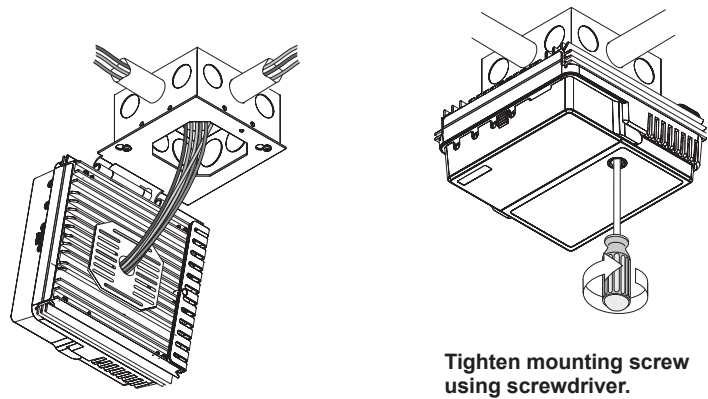

WARNING: To Reduce Risk of Electric Shock, unit shall be properly Grounded in accordance with NEC and Local Codes..

CONNECTIVITY

LMRJ connections shown are for example only. LMRJ cables can connect to any DLM device with an open RJ45 receptacle. All line voltage wiring is #12 AWG. Do not connect different load types to the same load output.

WIRING DIAGRAMS

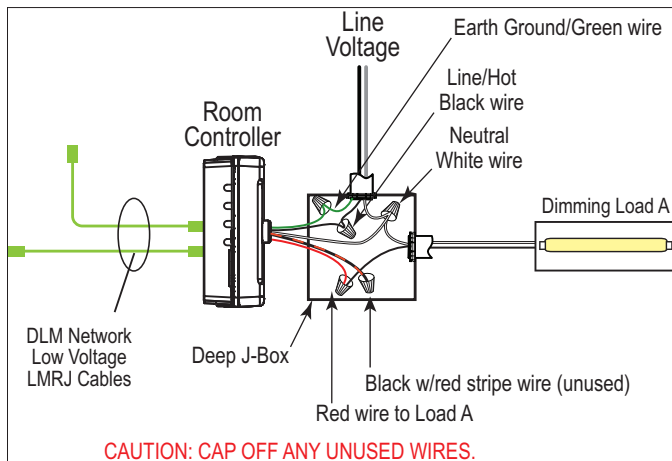

Incandescent, MLV, ELV, LED, Neon/cc, 2 Wire Fluorescent (Advance Mark X or equal)

NOTE: Do not connect different load types to the same load output.

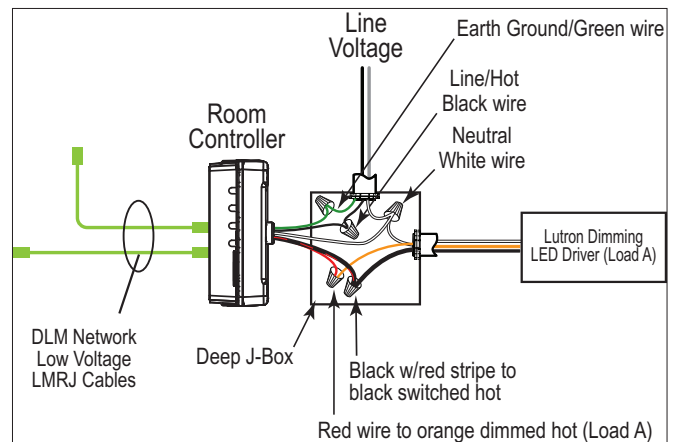

3 Wire LED Driver (Lutron or equal)

ATTACHING LMRJ LOW VOLTAGE CABLES

To access the RJ45 receptacles, lift the "clamshell" cover on the controller. Remove the rubber jack covers to use the RJ45 receptacles. Plug the cables into the receptacles then secure them under the strain relief hooks. Leave covers in place for all unused receptacles.

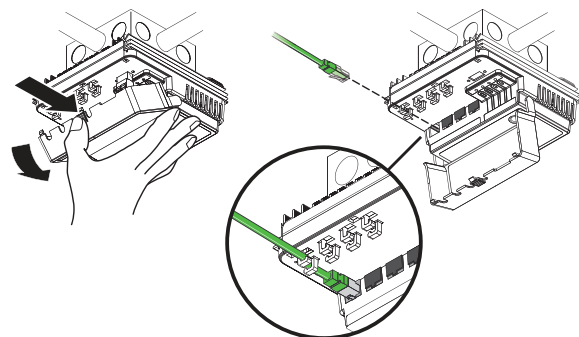

DIMMING CURVE SELECTION PROCEDURE

The Dimming Curve button allows selection of the appropriate curve for the connected load type. By default, the curve is factory set to Curve 1, which is for incandescent, MLV, LED, ELV, and neon/cc loads.

Step 1 Load Selection

Press and hold the Load button for the load that you wish to configure. The lights will dim down/up in a continuous cycle.

Step 2 Curve Selection

While continuing to **press and hold the Load Button**, **Tap and release the Dimming Curve Button** to select the correct curve for the connected load type (see Curve/Load Types table below).

Each subsequent tap of the dimming curve button will cycle to the next curve. This will be indicated by the frequency at which the yellow Dim Curve LED is blinking (see Curve/Load Types table below).

Button Selection Location and LEDs

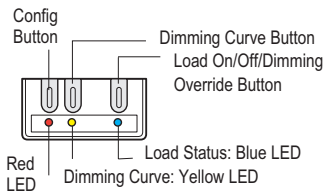

The Dimming Curve LED will blink according to load type below.

CURVE/LOAD TYPES	
Dimming Curve	Load Type
Curve 1 - 1 blink followed by a pause, then repeats.	(Incandescent/MLV/LED/ELV/Neon/cold cathode)
Curve 2 - 2 blinks followed by a pause, then repeats.	(2 wire floor; Advance Mark X or equal)
Curve 3 - 3 blinks followed by a pause, then repeats.	3 wire Lutron (Fluorescent/LED driver)
Curve 4 - 4 blinks followed by a pause, then repeats.	Low current LED/Incandescent lamps

NOTE: If you see flickering, pulsing, or any other anomaly with LED lamps when using curve 1, the load may not be meeting the minimum load requirement of the LMRC. In this case, please use curve 4 which helps optimize cases where the minimum load is not met.

Step 3 Exit Dimming Curve Selection

To exit Dimming Curve Selection, simply release the Load Override Button.

PLUG N' GO OPERATION (PNG)

Plug n' Go supports the most energy efficient control strategy. For example, if at least two loads, one switch and one occupancy sensor are connected to the DLM local network, the system operates

Load A as **Automatic ON, Automatic OFF** and Load B as **Manual-ON, Automatic-OFF**.

See DLM device Quick Start Guides to determine how each device affects the PNG operation of the LMRC-221.

Load A ON/OFF/Dim button

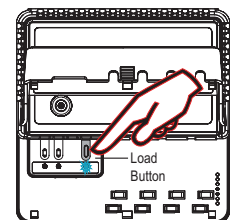

Blue LED **ON** when load is **ON**.

Load button:

Press & release for **ON/OFF**.

Press & hold to Dim.

Load Control Arbitration

To take full advantage of automatic PnG configuration, review these simple rules about load control arbitration.

After the room controllers are connected to the DLM Local Network and powered up, they automatically negotiate to determine which controller becomes the **Master**, and assigns the load numbers for each load output on the DLM Local Network.

The **Master** is the controller with the highest serial number. The LMRC-221 has one load output.

In a DLM local network with only LMRC-221 room controllers, the LMRC-221 with the highest serial number is the **Master**, carrying Load 1. The next highest serial number would have Load 2, and so forth.

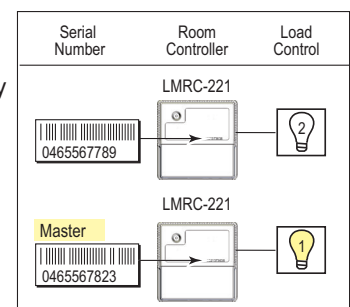

UNIT ADJUSTMENT - PUSH N' LEARN (PNL)

Load Selection Procedure

A configuration button (Config) allows access to our patented Push n' Learn™ technology to change binding relationships between sensors, switches, and loads.

Step 1 Enter Push n' Learn

Press and hold the Config button (on any DLM device) for 3 seconds.

The red LED on the LMRC-221 begins to blink. When you release the button, the red LEDs on other communicating devices connected to the DLM Local Network begin to blink. They continue to blink until you exit PnL mode.

All loads in the room turn **OFF** immediately after entering PnL, then one load will turn **ON**. This is Load #1, which is bound to Switch Button #1 and occupancy sensors as part of the Plug n' Go factory default setting. **All switch buttons and sensors that are bound to this load have their blue LED solid ON.**

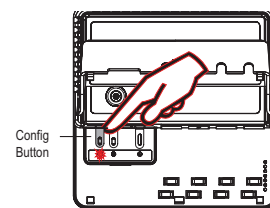

Config button & red LED

Step 2 Load selection

Press and release the Config button to step through the loads connected to the DLM Local Network. As each load turns **ON**, note the devices (switch buttons and sensors) that are showing a bright solid blue LED. These devices are currently bound to the load that is **ON**. The blue LED on the room controller or plug load controller connected to the load is also lit.

- To **unbind** a switch or dimmer button from a load, press the switch button while its blue LED is **ON** bright. The blue LED goes dim to indicate the button no longer controls the load that is currently **ON**.
- To **unbind** an occupancy sensor, press the up (▲) or down (▼) adjustment button while its blue LED is **ON**. The blue LED turns **OFF** to indicate the sensor no longer controls the load that is currently **ON**.

Pressing the switch button or sensor up (▲) or down (▼) again while the load is **ON** **rebinds** the load to the button or sensor and the blue LED illuminates brightly.

Step 3 Exit Push n' Learn

Press and hold the Config button until the red LED turns **OFF**, approximately 3 seconds.

TROUBLESHOOTING

LEDs on a switch or sensor don't light	<ol style="list-style-type: none"> 1. Check to see that the the device is connected to the DLM Local Network. 2. Check for 24VDC input to the device: Plug in a different DLM device at the device location. If the device does not power up, 24VDC is not present. <ul style="list-style-type: none"> • Check the high voltage connections to the room controller and/or plug load controller(s). • If high voltage connections are good and high voltage is present, recheck DLM Local Network connections between the device and the room controller(s).
The wrong lights and plug loads are controlled	<ol style="list-style-type: none"> 1. Configure the switch buttons and sensors to control the desired loads using the Push n' Learn adjustment procedure.
LEDs turn ON and OFF but load doesn't switch	<ol style="list-style-type: none"> 1. Make sure the DLM local network is not in PnL. 2. Check load connections to room controllers and/or plug load controllers.
Lamps do not dim, or lamps drop out at low dim levels	<ol style="list-style-type: none"> 1. Make sure a compatible dimming ballast and rapid start sockets are installed per the ballast manufacturer's recommendation. Shunted sockets are typically not acceptable. 2. Check wiring per ballast manufacturer's instructions.

WARRANTY INFORMATION

Wattstopper warrants its products to be free of defects in materials and workmanship for a period of five (5) years. There are no obligations or liabilities on the part of Wattstopper for consequential damages arising out of, or in connection with, the use or performance of this product or other indirect damages with respect to loss of property, revenue or profit, or cost of removal, installation or reinstallation.

INFORMATIONS RELATIVES À LA GARANTIE

Wattstopper garantit que ses produits sont exempts de défauts de matériaux et de fabrication pour une période de cinq (5) ans. Wattstopper ne peut être tenu responsable de tout dommage consécutif causé par ou lié à l'utilisation ou à la performance de ce produit ou tout autre dommage indirect lié à la perte de propriété, de revenus, ou de profits, ou aux coûts d'enlèvement, d'installation ou de réinstallation.

INFORMACIÓN DE LA GARANTÍA

Wattstopper garantiza que sus productos están libres de defectos en materiales y mano de obra por un período de cinco (5) años. No existen obligaciones ni responsabilidades por parte de Wattstopper por daños consecuentes que se deriven o estén relacionados con el uso o el rendimiento de este producto u otros daños indirectos con respecto a la pérdida de propiedad, renta o ganancias, o al costo de extracción, instalación o reinstalación.