



NETWORK ALL YOUR HVAC EQUIPMENT
 Monitor, update and control System Information from the mobile app
 Centralized DDC Communications for
 Stand-Alone HVAC and Zoned Modulating Systems



Zone	Temp	Occupied Heat/Cool	Unocc Heat/Cool
1. Board	70.9°	68/72	68/82
2. Cora	68.7°	68/73	68/82
3. New Office	72.3°	68/72	68/82
4. Lab	61.7°	68/72	68/82
5. Cherry	72.3°	71/73	68/82
6. Elm	70.3°	68/74	68/82
7. Jeff	71.0°	68/72	68/82
8. Charlie	71.1°	68/73	68/82
9. Conference	73.0°	68/73	68/82
10. Zone 10	68.4°	65/78	68/82
11. Zone 10	68.4°	65/78	68/82
12. Zone 11	68.4°	65/78	68/82



INSTALLATION AND APPLICATIONS MANUAL
USING WIRED THERMOSTATS

GEN X

CONCEPTUAL OVERVIEW

NETWORK AND CONTROL VVT SYSTEMS
ALONG WITH MULTIPLE STAND ALONE RTU OR SPLIT SYSTEMS FROM YOUR MOBILE DEVICE

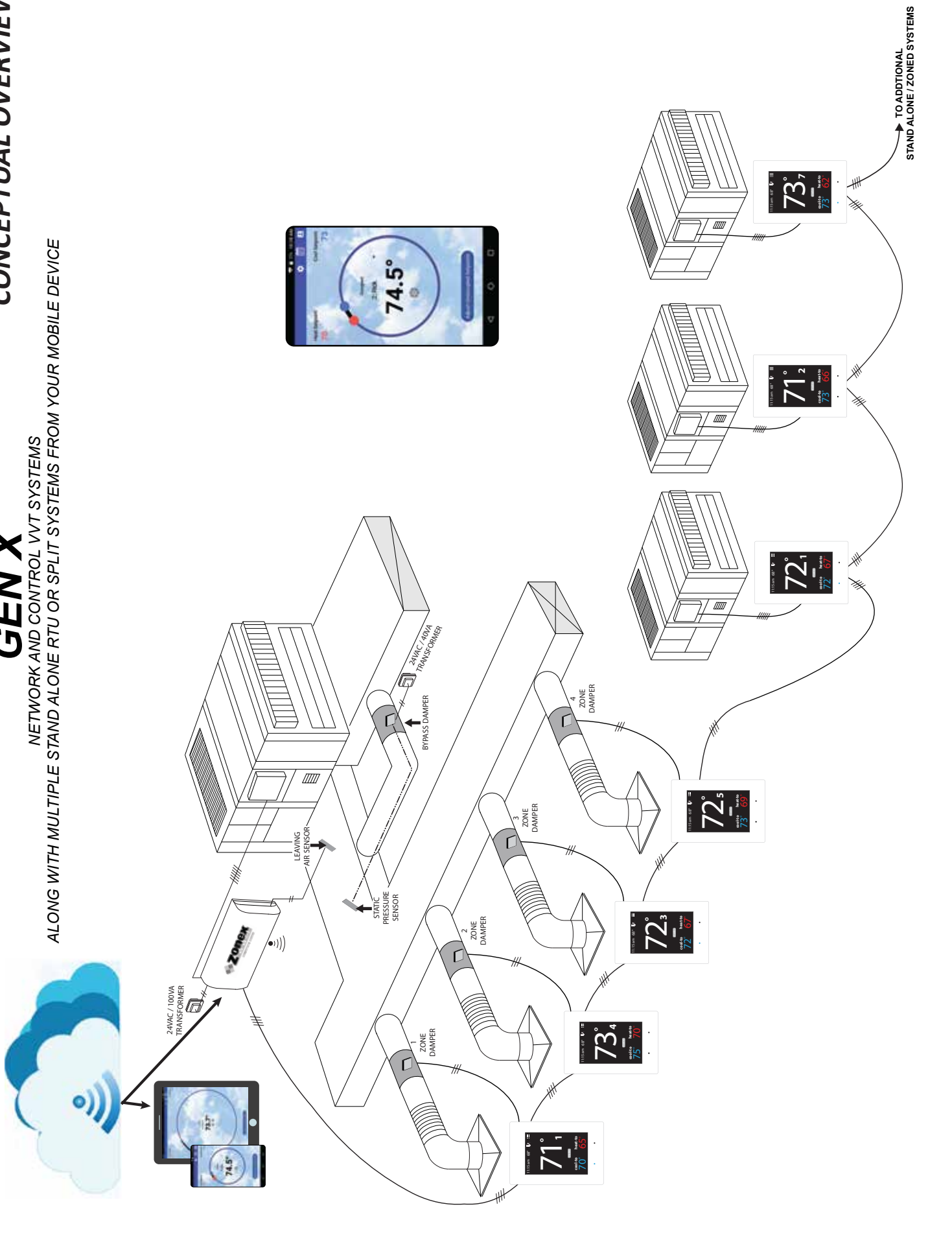

NOTE: USE ZONEX, 2 WIRE TWISTED PAIR COMMUNICATION LINK

* FOR THE 24V POWER, SIZE THE WIRE BASED ON LENGTH OF RUN

TO ADDITIONAL
STAND ALONE / ZONED SYSTEMS

GEN X is a commercial modulating bypass VAV system controlling 2-20 independent zones per RTU or split system utilizing Zonex wired thermostats that communicate remotely over the Internet with our App and a phone or mobile device from ANYWHERE. GEN X RM controllers are used to expand your system to control multiple zoned or stand alone units remotely. GEN X can support up to 20 RM expansion controllers providing control of up to 400 units, zone dampers or other control points in your system, seamlessly accessed via the App, or any browser from the end user interface.

The GEN X controller is designed for Auto Changeover, bypass VAV operation for multi-stage Heat Pump (2C/3H) or Gas Electric (2C/2H) applications. The GEN X supports VAV boxes and VFD type systems.

The GEN X mobile App allows for a wide range of system control and changeover strategies, allowing the contractor to tailor the GEN X system to a specific application, remotely or on-site.

Additional features include LED status indication of all system functions, digital leaving air temperature, return air temperature and outside air temperature display, fully adjustable capacity control with on-board limit settings and optional staging strategies. Morning warm up, email/text alerts, priority votes, and air balance features are also included. An integrated clock allows for setup, night setback, vacation scheduling, globally or individually for each zone thermostat, with selectable 2 to 8 hour override, and the ability to remotely lock each thermostat in the system. Additionally a unique system tool provides the installing contractor with a simple startup diagnostic to quickly alert and identify any system wiring errors, all from the palm of your hand using the GEN X mobile App.

GEN X is recognized as the industry's easiest commercial zone control system to install and wire. The GEN X system operates over a plenum rated 2 wire data link, along with two 24VAC power wires daisy chained from thermostat to thermostat with no home run wiring required. Communication and configuration is done through the GEN X mobile App. GEN X can control zoned systems along with standalone units or generic loads, ie. fans, pumps, lights, ect. Zonex stand alone thermostats are utilized to control stand-alone (non-zoned) HVAC equipment and a RLYX controller is utilized to control the generic loads.

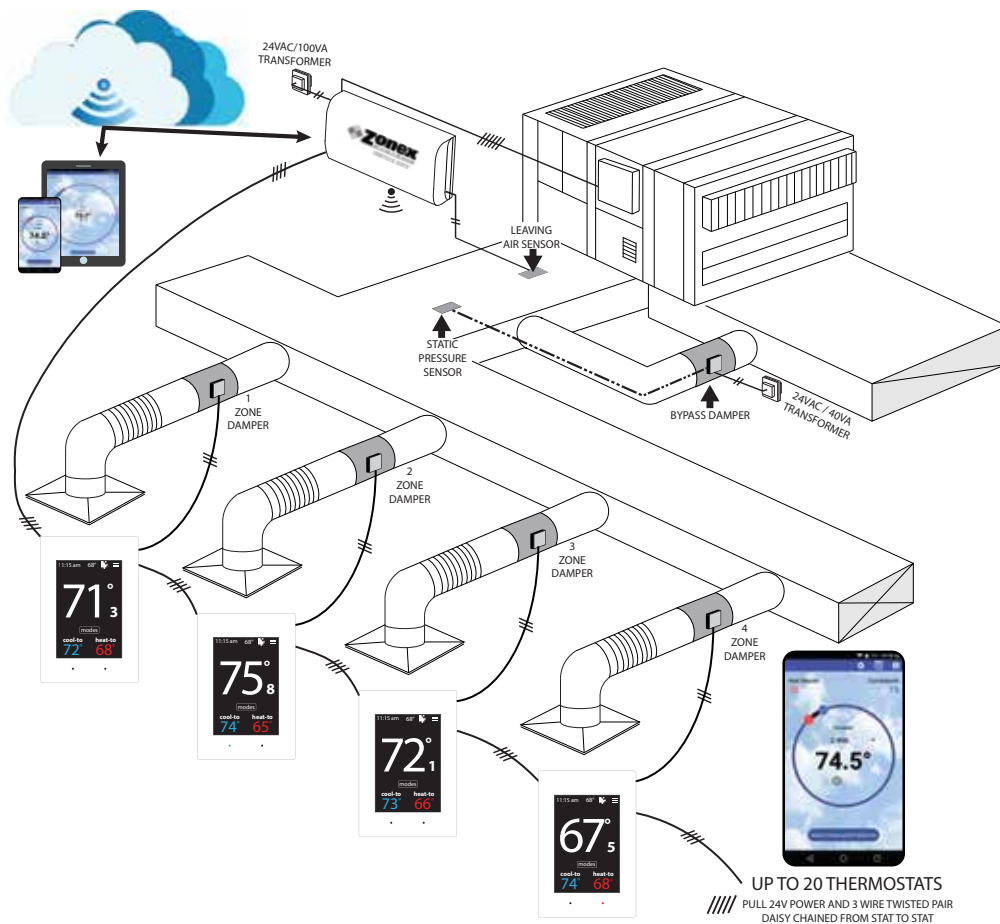
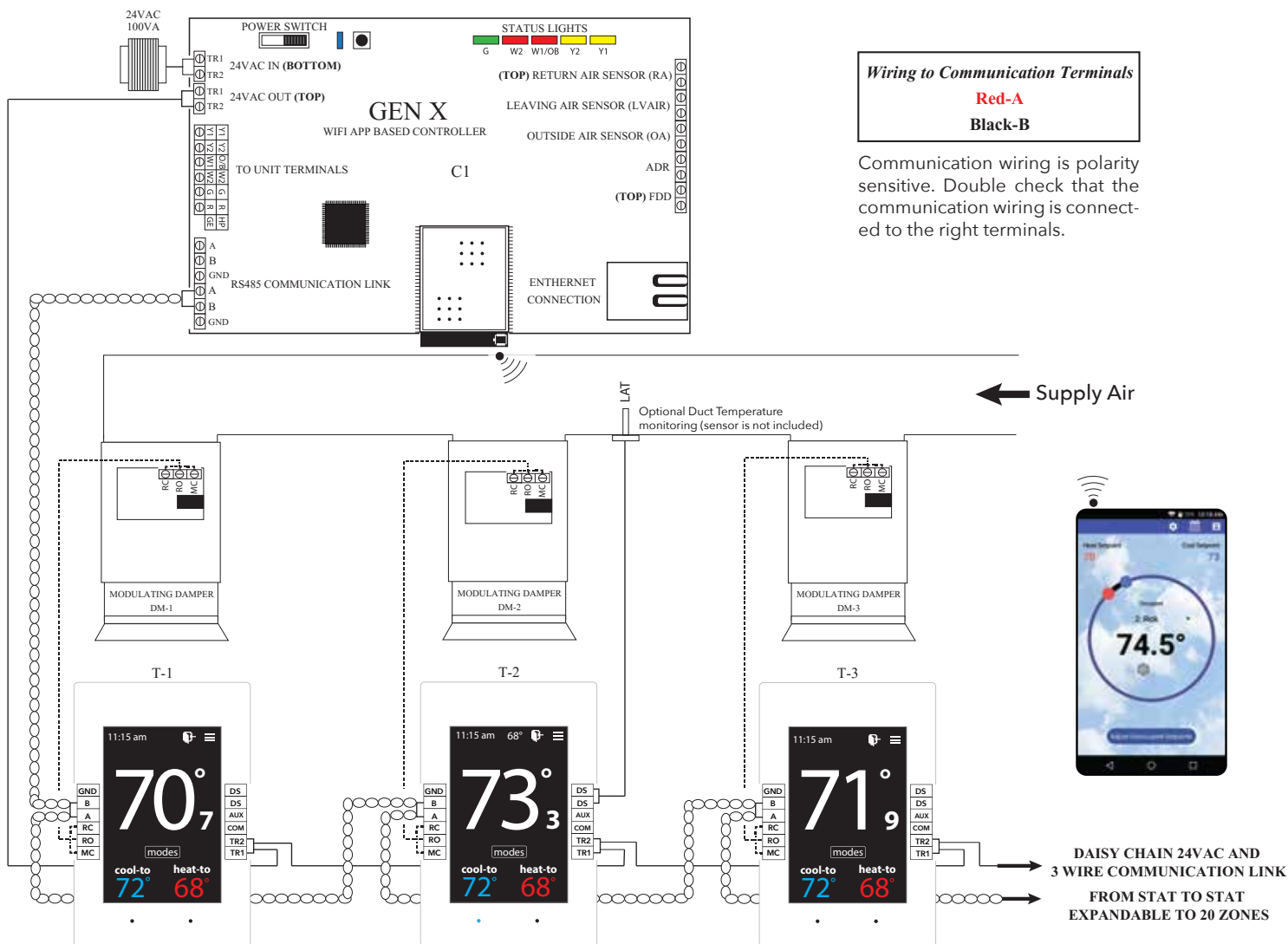

TABLE OF CONTENTS

1	QUICK START AND OVERVIEW	5
	Quick Start and Commissioning	5-7
	Mobile App Overview	8-9
	Component Selection Guide	10
	Sequence of Operation	11
	System Schematic Overview	12
2	SYSTEM COMPONENTS	13
	GEN X Controller	13
	GEN X RM Expansion Controller	14
	RLYX Generic Load Controller	15
	EzTouchX Zone Thermostat	16-17
3	INSTALLATION INSTRUCTIONS	18
	GEN X Controller	18-20
	GEN X ADR and FDD Installation	21
	GEN X RM Expansion Controller	22-24
	GEN X RM FDD Installation	25
	RLYX Generic Load Controller	26
4	COMMISSIONING AND START UP	27
	ID'ing Zone Thermostats	27
	Downloading the Mobile App and Connecting to the GEN X	28
	Commissioning and Start up of the GEN X	29-32
	Commissioning and Syncing of the GEN X RM	33
	Commissioning and Syncing of the RLYX	34
5	ZONE THERMOSTAT OVERVIEW AND OPERATION	35
	EzTouchX Overview and Configuration	35-36
	EzTouchX Configuration Menu	37-39
	EzTouchX Advanced Menu	40-42
	Auxiliary Heat / Reheat / W1 First Operation	43
	Supplemental Heat - Wiring Options	44
6	GEN X NETWORK CONNECTION AND ACCOUNT SET UP	45
	Android Wireless Connection Configuration	45
	Apple Wireless Connection Configuration	46
	Account Set up for Internet Connection	47
7	GEN X MOBILE APP OVERVIEW AND OPERATION	48
	System Configuration Menu, Schedule / Vacation	48-49
	Lock, Thermostat Lock Mode, Turn Thermostat ON/OFF	50
	System Diagnostic, High / Low Limit, Second Stage Delay, Override Hours	51-52
	Priority Vote, Fan Mode, Unit Type, Set Maverick, Enable Morning Warm Up	53-54
	Temperature Format, Air Balance Mode, Set Stat Zone Names	55
	Change GEN X / RM Unit Names, Configure Number of Dampers	56
	Configure Number of RM's Attached to System	56
	Assign RM ID, Configure Number of RLYX Attached to System	57
	Assign RLYX ID, See Zone Overview, Change Alarm Settings	57-58
	Change ADR Settings	59
	Extended Menu Options	60
8	GEN X WEB-PORTAL INSTRUCTIONS	61
	Web-Portal Login	61
	Zone Overview and Changing Zone Thermostat Temperatures	62-63
	Diagnostics Screen and Schedule / Vacation Set up	64-66
	Changing Temperature Format and Zone Names	67
9	SATOUCHX THERMOSTAT INSTALLATION AND CONFIGURATION	68
	SATouchX Universal Thermostat	68
	Installation Instructions	69
	SATouchX Configuration and Operation	70-71
	SATouchX Configuration Menu	72-75
	SATouchX Advanced Menu	76-78
10	ZONE DAMPERS	79
	Round and Rectangular Sizing and Selection	79-81
	Slaving Zone Dampers	82
11	BYPASS DAMPERS	83
	Slaving Bypass Dampers	83
	Bypass Installation	84-85
	IPC - Static Pressure Controller	86-87



Wiring and Installation

1. Install GEN X controller inside the conditioned space, in a area that is easily accessible.
2. Install an Independent 24VAC/100VA transformer, wire the secondary 24VAC output to the TR1 and TR2 (IN) bottom terminal on the GEN X controller. **DO NOT ground out the transformer.**
3. Install the Leaving air sensor (LV Air) in the supply duct, prior to the bypass. Wire the Leaving air sensor to the LV Air terminals on the GEN X controller. Install Return air sensor (RA) in the return duct, after the bypass. Wire Return air sensor to the RA terminals.(May extend sensor wire using 18/2 thermostat wiring.) (See page 19)
4. Install Supply Dampers and Bypass Dampers. (See page 80)
5. Wire TR1 and TR2 (OUT) top terminal from the GEN X controller to the first zone thermostat (EzTouchX) TR1 and TR2 using 18/2 thermostat wire. (See page 18.) Continue daisy chaining TR1 and TR2 on the EzTouchX to the next EzTouchX until the last EzTouchX or Standalone thermostat (SATouchX) in the system. Make sure TR1 and TR2 polarity is consistent throughout the system.
6. Wire A and B from the GEN X controller using Zonex 2 wire Plenum rated twisted pair wire (Part #STPR) to the first zone thermostat (EzTouchX). (See page 18.) Continue daisy chaining from A and B on the EzTouchX to the next EzTouchX until at the last EzTouchX board or SATouchX in the system. Make sure A and B polarity is consistent throughout the system.
7. Turn ON the GEN X controller, confirm that the GEN X , EzTouchX's, and SATouchX's (if applicable) are powered. A blue light on the GEN X controller indicates it is powered. If you do not have a blue power light confirm power at the transformer and check TR1 and TR2 wiring.





Configuring Thermostat ID's

- Every thermostat in the system needs a unique ID ranging from 1-20. They must be in numerical order the way the communication wire is daisy chained. Confirm no duplicate addresses.

To set the stat's ID access the Advanced Configuration menu by tapping on the degree symbol next to the room temp . The degree symbol will change from white to green and then tap 

Once in the Thermostat Advanced Menu, Select **SET ID**

Use the  and  arrows and set the new ID ranging from 1-20



Tap  to save changes, to return to the home screen tap 

(Repeat the steps above, All stats are ID'ed as 001 to 020, maximum of 20 zones on each GEN X / GEN X RM system.)

- If GEN X RM's are being installed to support additional HVAC units see page 22. If not skip this step.

Select Damper Type Operation

- The EzTouchX needs to be configured for the type of damper that it is wired to. There are 4 options, round, rectangular, spring loaded or vrf.

To set the damper type access the Advanced Configuration menu by tapping on the degree symbol next to the room temp . The degree symbol will change from white to green and then tap 

While in Thermostat Configuration Menu, **Select Damper Type**



Select round, rectangular, spring loaded or vrf damper operation

Tap  to save changes, to return to the home screen tap 

Connecting to the GEN X controller via the Mobile App

- Download the GEN X mobile App from the Google Play or Apple App store and install it on your mobile device.
- Connect the GEN X to the building's Local Area Network (LAN)(Router or Switch) with an Ethernet cable. If a wired network connection is not available, please go to page 45 for direct wireless connection to the GEN X using your mobile device.
- Connect your mobile device via Wi-Fi to the same network the GEN X is connected. You may need to get the SSID/network name and password from the network administrator or IT personnel.
- Open the GEN X mobile App and Tap **Scan LAN for GEN X**. Once the scan is complete, Tap **Select Local GEN X** at the top of the screen. A drop down menu will appear allowing you to select a GEN X controller. If more than one is displayed, Tap the system you want to connect to.

System Configuration

15. Tap  for System Configuration Menu; scroll down to **Configure # of Thermostats** and indicate how many thermostats are wired to the GEN X controller.(See page 27.)
16. Tap **System Diagnostic**, confirm Leaving Air, Return Air, and Outdoor Air are reading temperatures. Also confirm under Thermostat Status that all Zones are Active.
17. While still in System Configuration, choose **Unit Type**. Select **Gas, Electric or Heat pump**.
18. See System Configuration Menu on page 48 to further configure the GEN X controller.
19. Scroll to Zone Overview and select, All zones should be showing room temperatures. Tap any zone to change set point for Heating and Cooling. See page 8 on how to use the App. Adjust your cool set point and Tap  at the top of the App. This will take you back to the zone overview screen. The zone room temperature should show in blue and the GEN X controller should be energized G (Green) and Y1 (Yellow) lights confirming cool call operation. Satisfy all zones calling for cooling and repeat the steps above for a heat call and confirm W1 (Red) light or Y1 (Yellow) and G (Green) lights for Heat pump operation.
20. Wire the GEN X controller to the RTU or split system. (See page 20).
21. Make a cool call from each zone thermostat and check register to ensure each damper opens and closes as you make and satisfy calls.

MOBILE APP OVERVIEW

The Zonex App gives you direct access and control to every thermostat connected to the GEN X system.

These Menu shortcuts at the top of the screen allow you to quickly navigate the GEN X App.

- Overview Screen
- Schedule/Calendar
- System Configuration Menu
- Extended Menu Options

The Overview Screen provides a quick look at all temperatures in your system, current calls for heat or cool along with listing the occupied and unoccupied set points.

Tap the icon to access the Overview screen which displays the following:

1. Zone number
2. Zone name
3. Current room temperature of each thermostat
 - Note: Room temperatures displayed in Blue are calling for cooling or Red if the zone is calling for heat. A flashing room temperature indicates a call that has not yet been addressed. Room temperatures in black are zones that have been satisfied.
4. Occupied Heat / Cool set points. (Bold temperatures indicate current mode).
5. Unoccupied Heat / Cool set points. (Bold temperatures indicate current mode).

Zone	Temp	Occupied Heat/Cool	Unocc Heat/Cool
1: Gene	72.3°	66/73	66/85
2: Marcos	72.6°	66/74	60/95
3: Main Off	72.9°	66/72	60/95
4: Joe	70.7°	66/72	60/95
5: Cheryl	73.0°	69/74	60/95
6: Ellie	74.6°	67/74	60/95
7: Jeff	72.2°	66/72	60/95
8: Charlotte	72.7°	67/72	60/95
9: Conf	73.0°	68/73	60/95

Tap any thermostat to make an individual or global temperature set point change.

Familiarize yourself with the thermostat features and simple operation:

Labels and descriptions for the thermostat control screen:

- Access System Configuration Menu**: Points to the gear icon in the top navigation bar.
- Access Schedule / Calendar**: Points to the calendar icon in the top navigation bar.
- Access Overview Screen**: Points to the hamburger menu icon in the top navigation bar.
- Access Extended Menu Options**: Points to the vertical dots icon in the top navigation bar.
- Heat Set Point**: Points to the red number '66' on the left side of the thermostat interface.
- Cool Set Point**: Points to the blue number '72' on the right side of the thermostat interface.
- Drag Blue Dot to Adjust Cool Set Point**: Points to the blue dot on the circular temperature slider.
- Zone Number**: Points to the text '3: Main Off' in the center of the thermostat interface.
- Drag Red Dot to Adjust Heat Set Point**: Points to the red dot on the circular temperature slider.
- Occupied / Unoccupied Mode**: Points to the 'Occupied' text in the center of the thermostat interface.
- Tap ▼ to Access All Thermostats**: Points to the downward arrow icon in the center of the thermostat interface.
- Room Temperature**: Points to the large number '72.9°' in the center of the thermostat interface.
- System Status Cool / Heat / Vent**: Points to the snowflake, flame, and fan icons at the bottom of the thermostat interface.
- Lock Icon**: Points to the padlock icon at the bottom of the thermostat interface.
- Tap Here To Change Unoccupied Set Points**: Points to the 'Adjust Unoccupied Setpoints' button at the bottom of the thermostat interface.

System Diagnostic screen provides an overview of the system’s current conditions. Tap the  icon and then locate and tap **System Diagnostic** to view the following information:

1. The number of thermostats in the system
2. Leaving, Return and Outside air temperatures
3. Main system status: displays current operation, either Cool, Heat, Vent mode or Changeover
4. Number of heating and/or cooling calls.

Note: GEN X is a vote based auto changeover system that polls each thermostat every 60 seconds to determine if a zone requires cooling, heating or is satisfied. System operates on a first call, first served majority wins on changeover strategy. If the system counts more heating than cooling votes then the system will operate in the heating mode, until it detects a majority of cooling votes, at which time it will initiate a changeover cycle, energize the compressor and cooling. Dampers drive closed in the heating zones and modulate to the open position in zones calling for cooling.

5. Thermostat status: indicates if each thermostat is active (wired and communicating properly with the system), and reports any wiring errors in the system.

The App is a great tool to diagnose and / or avoid potential problems with your system.

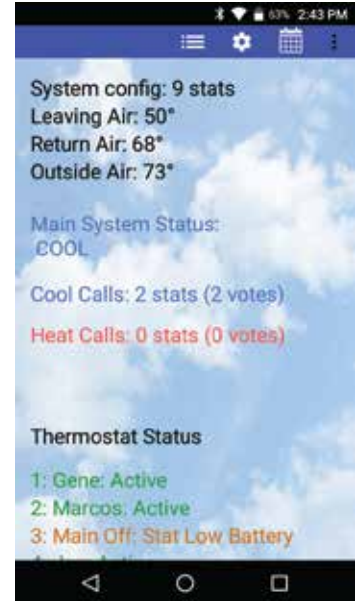

Schedule/Calendar is used to schedule occupied or unoccupied periods individually or globally for each thermostat and vacation days.

Tap the  icon to configure the following:

1. Select 5-1-1 (Mon - Fri, Sat - Sun), 7 day operation or 24/7 operation
2. Set Daily schedule
2. Set 2nd Daily schedule (optional)
3. Set vacation schedules
4. Enable vacation schedules

The **Extended Menu** provides shortcut access to the following, by tapping on the  icon:

1. System diagnostics
2. Log out of Account
3. Change RM/GEN X (same system)
4. Change RM/GEN X (separate system)
6. Exit the App

This App provides direct system access, either on-site or remotely, putting control right in the palm of your hand. For more detailed information and operating instructions explore this GEN X manual.

GEN X

Wi-Fi APP Based Controller

Part # - **GEN X**

Includes Mobile APP

1 - Per RTU or Split System
Supports 2 - 20 Fully Modulating Zones

Add Part # **GEN X-RM** to expand your GEN X system by adding a GEN X-RM controller for each additional zoned unit.
(Each GEN X-RM supports 2-20 fully modulating Zones or thermostats)

Daisy Chain: Zonex communications wire and 24VAC from Damper to Damper with wireless stats or Stat to Stat with wired stats
1-24VAC / 100VA Transformer Powers the GEN X and All the Dampers in the System
Each GEN X-RM expansion controller requires an additional transformer to support up to 20 dampers per GEN X-RM

Color Touch Screen Thermostat

Part # - **EzTouchX**

1- Thermostat per Damper
Slave Up to 3 Zone Dampers per Stat

Modulating Zone Dampers

Part # -

STMPD + Damper Size - Round Dampers (up to 1.75 S.P)
STCD + Damper Size - Rectangular Dampers (up to 1.75 S.P)

Thermostat to Control Standalone Units

Part # - **SATouchX**

Controls and Networks Standalone RTU or Split systems
with SA / RA / RH reporting from the mobile app

Electronic By-Pass Damper

Part #

STBP + Damper Size Round By-Pass Dampers
STCDBP + Damper Size Rectangular By-Pass Dampers
(Includes Integrated Static Pressure Control)
1-24VAC / 40VA Transformer to Power By-Pass Damper

THIS COMPLETES YOUR GEN X SYSTEM

For assistance, contact Zonex at (800) 228-2966
or visit zonexproducts.com for more information

Vote Based Auto Changeover Bypass VAV with Programmable Thermostats Accessed Remotely or On-site from a Phone, Mobile Device or Web Browser

GEN X controller wires to the HVAC unit with legacy style connections Y1, Y2, W1/OB, W2, G, R. Every minute the controller communicates to each zone thermostat via RS485 connection daisy chained along with 24VAC power wired thermostat to thermostat. Each zone thermostat is given a unique ID that communicates back to the GEN X controller.

The GEN X is an auto changeover, vote based VVT system. As thermostats call for heating or cooling, votes are tallied by the GEN X controller and based on the majority of votes received the HVAC unit operates in the mode of majority votes. If majority changes, the system controller will automatically initiate a changeover sequence with built in time delays to protect the equipment before changing over to the new mode of operation.

When the last calling zone is satisfied (in either heat or cool mode), the GEN X controller will terminate outputs to the HVAC unit after the next "poll"; and the blower output will de-energize (unless controller is configured for constant fan) after a 3-minute purge cycle. During the purge cycle no heat or cool calls are recognized.

The zone thermostats control and modulate zone dampers based on variance from set point to a position that will match the demand requirement. When the HVAC unit is running, if a zone thermostat is not calling or is calling for the opposite mode, its corresponding damper fully closes. When the HVAC unit is not running, the thermostats open to the Vent mode to provide ventilation if the indoor blower fan is running continuously. When configured for Reheat operation and the zone temperature drops 2° below thermostat set point, the damper modulates to approximately 40% open providing airflow over electric heat strips or other supplemental heat source, the AUX terminal will energize and strip heat will energize.

While the HVAC unit is running, the capacity control LAT (leaving air temperature sensor) monitors the leaving air temperature from the HVAC unit and will cycle the HVAC unit to maintain the air temperature with a preset range to prevent coil freeze-up and premature heat exchanger failure. When the system is in the heating mode and a majority vote changes to cooling, a changeover timer begins and will run heating for 4 minutes or until heat call is satisfied and then cycle into a changeover purge. After a 3-minute purge cycle, cooling is energized until the cool call is satisfied or there is a majority vote for heat received by the GEN X controller. If all calls have been satisfied, after the 3-minute off delay, dampers will modulate to approximately 40% open position for ventilation mode.

The system fan/blower operation can be configured for ON or intermittent AUTO operation.

All Zone thermostats are wired to their respective modulating zone damper. Thermostats, scheduling and diagnostic reports to streamline system troubleshooting, are generated from the mobile App that interacts with all thermostats every minute and initiates control decisions for the system. The mobile App shall establish global or individual schedules for the system, lock thermostats individually and provide local adjustment, on site or remotely over internal Wi-Fi or the Internet. Air balance shortcuts, along with password protection, are also enabled from the App. Sleep and energy saving modes are available to extend battery life and enhance operation of the thermostats.

Voting demand strategy can be enhanced by adding Priority votes or by giving a NULL vote to individual thermostats in the system, thereby weighting certain zones more than others. Priority votes allow you to select 0, 1, 2, or 3 additional votes for a thermostat that has unusual loads, such as a conference room. A change to 0 for priority in that zone stat configuration will create a NULL vote for the HEAT/COOL and will not allow the stat to place a call for heat or cool, but will allow damper operation based on system mode of operation, HEAT/COOL/VENT.

Additional zoned systems, along with stand alone units and generic loads may be controlled with the GEN X RM or RLYX controller that supports and networks additional units. Mobile Wi-Fi or web based App streamlines installation, commissioning or servicing the system.

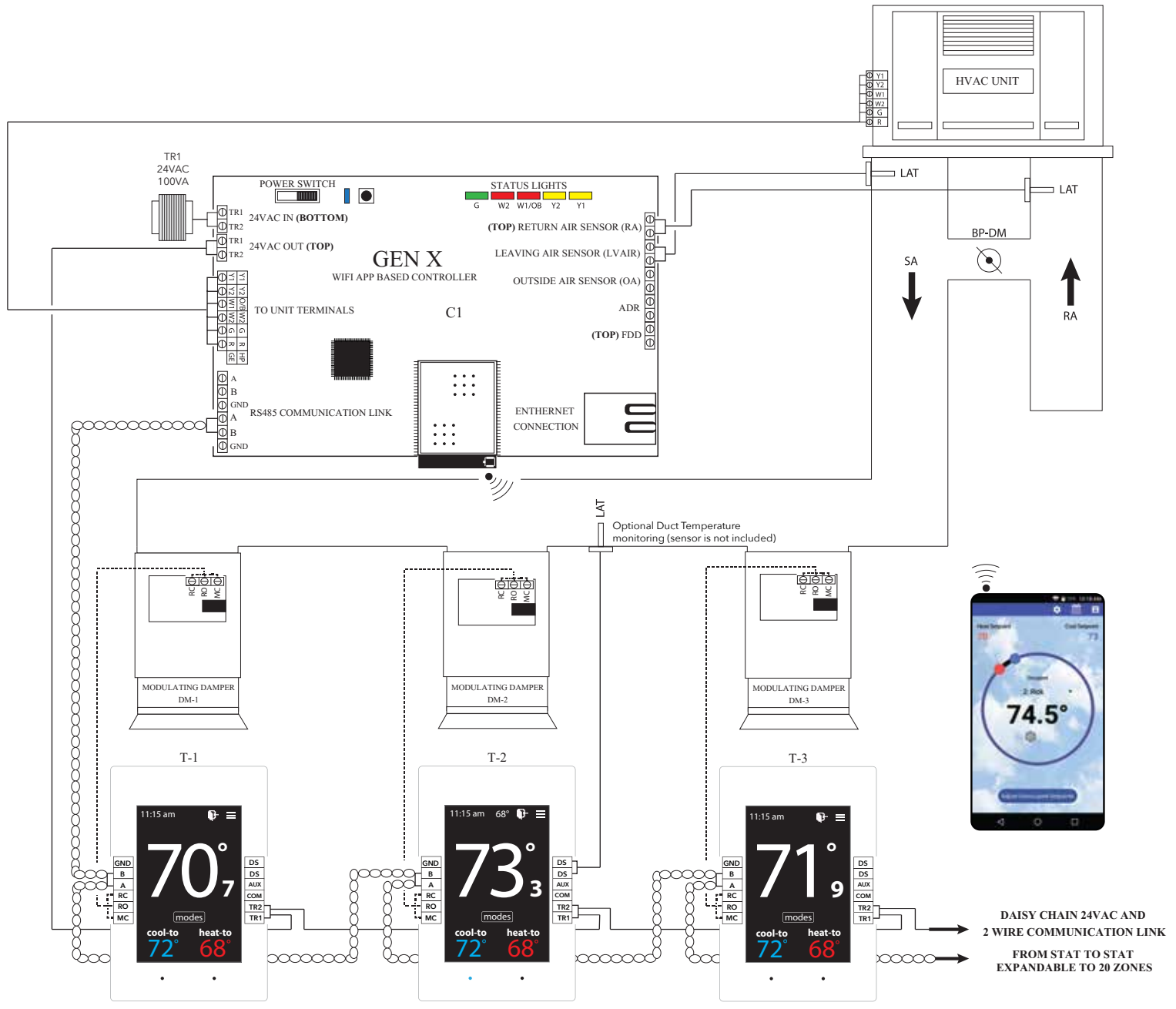

DEVICE	ID	DESCRIPTION	DEVICE	ID	DESCRIPTION
MOBILE APP, Wi-Fi BASED CONTROL BOARD	C1	GEN X CONTROLLER CONTROLS 2-20 MODULATING DAMPERS 1-24VAC/100VA TRANSFORMER POWERS ALL SUPPLY DAMPERS	SUPPLY / RETURN AIR LAT DISCHARGE SENSORS	LAT	SUPPLY LAT LOCATED BEFORE THE BYPASS. RETURN LAT LOCATED AFTER THE BYPASS
THERMOSTAT	T1-T20	COLOR TOUCH SCREEN THERMOSTAT	24VOLT WIRING TO EzTouchX's	—	USE 18GA THERMOSTAT WIRE TO DAISY CHAIN THE 24VOLTS FROM STAT TO STAT
ZONE DAMPER ACTUATOR	DM	SUPPLIED WITH ZONE DAMPER	RS485 COMMUNICATION LINK	○○	ZONEX 2 WIRE TWISTED PAIR
SYSTEM TRANSFORMER	TR1	24VAC/100VA TRANSFORMER (SIZED @ 5VA PER ZONE) DAISY CHAIN STAT TO STAT			

VISIT OUR ON-LINE CATALOG AT ZONEXPRODUCTS.COM
FOR APPLICATIONS ASSISTANCE CALL 800-228-2966



The GEN X is a micro-controller based, auto changeover Universal Gas/Electric or Heat Pump system controller (Part # **GEN X**). The **GEN X** controls a zoned 2H/2C Gas/Electric HVAC unit or 3H/2C zoned Heat Pump unit and communicates with and supports up to 20 zones, utilizing pressure dependent, modulating dampers and zone thermostats. The **GEN X** gathers information every 60 seconds from each thermostat and communicates with the system over a Zonex 2-wire plenum rated

twisted pair data link directing control based decisions to the HVAC equipment. The **GEN X** is powered with one 24VAC/ 100VA transformer, which also powers all thermostats and dampers in the system. Power from the controller, along with a Zonex 2-wire communications loop, is daisy chained thermostat to thermostat to streamline installation and system communications. The **GEN X** is equipped with integrated capacity control and High and Low temperature limits to protect the compressor and heat exchanger. Outside air and return air sensors are also provided. The HVAC unit is staged based on leaving air temperature and time. Auto changeover operation is vote based, predicated on a first call, first served majority wins on changeover algorithm. Additional control strategies are established with your mobile device using the GEN X mobile App which initiates control decisions remotely or on-site with the **GEN X** system controller. Time and Date from the phone or mobile device will automatically update on the GEN X when you log in over the local area network (LAN) via the mobile app. **Review controller terminal connections below:**

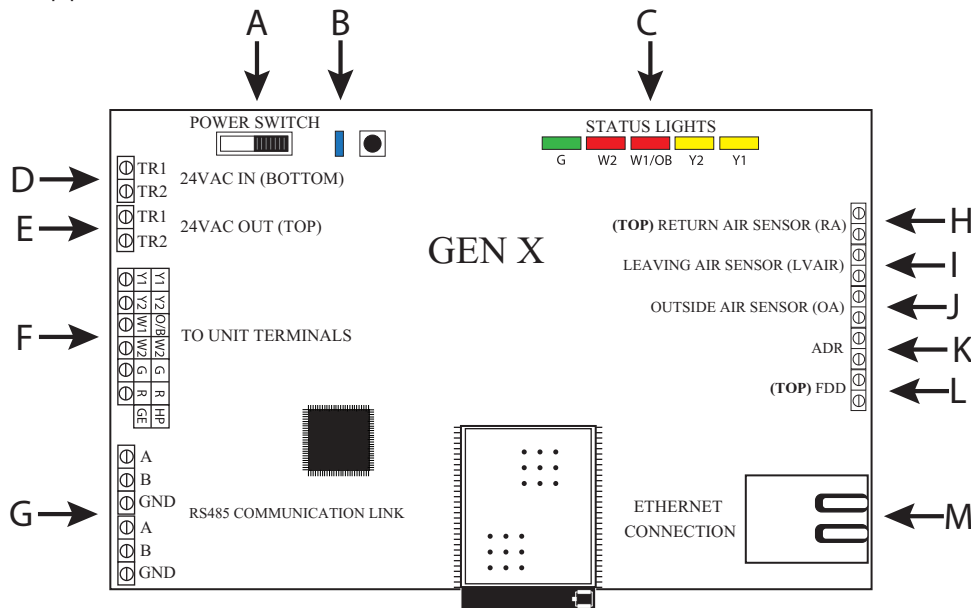

- A. On /Off Power Switch
- B. Communication link LED
- C. Unit Status Lights
- D. 24VAC IN (Bottom Terminal) to power the GEN X board (Independent 24VAC /100VA Transformer)
- E. 24VAC OUT (Top Terminal) daisy chained out to zone thermostats
- F. Unit Terminals
- G. A/B Zonex 2 wire communication link, daisy chained OUT to zone thermostats and GEN X RM (if utilized)
- H. Return Air Sensor (RA)
- I. Leaving Air Sensor (LVAIR)
- J. Outside Air Sensor (OA)
- K. Automated Demand Response (ADR)
- L. Fault Detection Device (FDD)
- M. Network Connection



The GEN X RM is a micro-controller based, auto changeover Universal Gas/Electric or Heat Pump system controller (Part # **GEN X RM**), designed to work with the GEN X controller to provide expansion capability to support additional zoned or stand alone units. The **GEN X RM** controls a zoned 2H/2C Gas/Electric HVAC unit or 3H/2C zoned Heat Pump unit and communicates with and supports up to 20 zones, utilizing pressure dependent, modulating dampers and zone thermostats.

The **GEN X RM** gathers information every 60 seconds from each thermostat and communicates with the system over a Zonex 2-wire communications link directing control based decisions to the HVAC equipment. The **GEN X RM** is powered with one 24VAC/100VA transformer, which also powers all thermostats and dampers in the system. Power from the controller, along with a Zonex plenum rated 2-wire twisted pair communications loop, is daisy chained thermostat to thermostat to streamline installation and system communications. The **GEN X RM** is equipped with integrated capacity control and High and Low temperature limits to protect the compressor and heat exchanger. Return air sensor is also provided. The HVAC unit is staged based on leaving air temperature and time. Auto changeover operation is vote based, predicated on a first call, first served majority wins on changeover algorithm. Additional control strategies are established with your mobile device using the GEN X mobile app which initiates control decisions with the **GEN X RM** controller. Review controller terminal connections below:

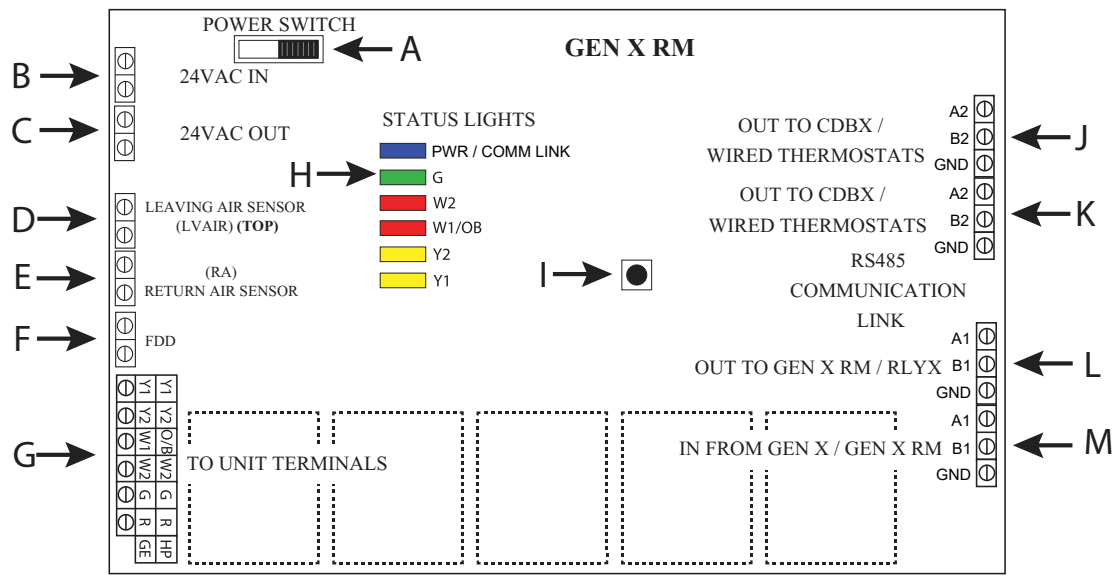

- A. On /Off Switch
- B. 24VAC IN to power the GEN X RM board (Independent 24VAC /100VA Transformer)
- C. 24VAC OUT daisy chained out to zone thermostat
- D. Return Air Sensor (RA)
- E. Leaving Air Sensor (LVAIR)
- F. Fault Detection Device (FDD)
- G. Unit Terminals to Manufacturers Interface
- H. Communication link LED / Unit Status Lights
- I. Sync Button
- J. A2/B2 2 wire communication link, daisy chained OUT to zone thermostats
- K. A2/B2 2 wire communication link, daisy chained OUT to zone thermostats
- L. A1/B1 2 wire communication link, daisy chained OUT from GEN X RM to GEN X RM or RLYX
- M. A1/B1 2 wire communication link, daisy chained IN from GEN X or GEN X RM



The RLYX is a communicating device equipped with 5 SPST relay terminals switched between a single Common terminal (NOT as dry contacts independent from each other). The RLYX can be used to control loads such as fans, pumps, blowers, lighting, or any load that can be operated using low voltage signals of 24VAC or less. When a relay is energized a circuit is completed between Common and the corresponding relay terminal (i.e. Common and R1, Common and R2 and so on). Status of the relays are

displayed as either ON or OFF under the Zone Overview or System Diagnostics screens of the GEN X App and LED indicators on the RLYX board. Relays will energize in the Occupied mode and de-energize in the Unoccupied mode. One Occupied and one Unoccupied event can be scheduled per day for each relay/load on either a daily basis or on 5-1-1 basis (Mon-Fri, Sat-Sun). Each relay terminal on the RLYX can be configured with its own independent schedule tailored to the needs of each load. The RLYX can also be configured with Vacation Schedules for holidays or other special events when the building will be Unoccupied during the regular schedule. If more than five loads are to be controlled then additional RLYX's will be required. The GEN X can support up to twenty RLYX and/or GEN X RM controllers, if the application requires more than twenty RLYX and/or GEN X RM controllers then additional GEN X's will be required.

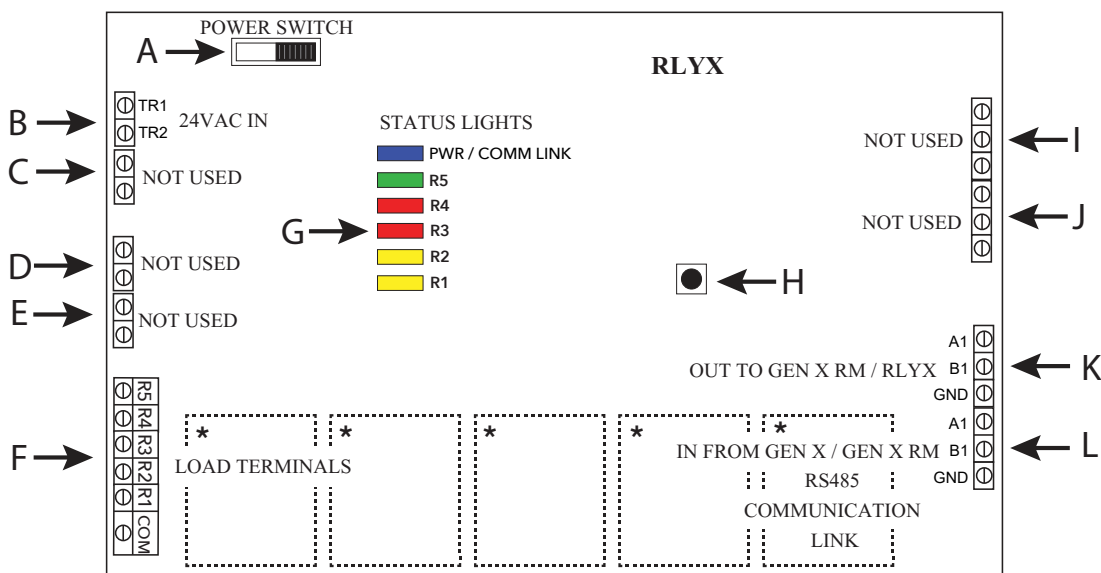

- A. On /Off Switch
- B. 24VAC IN to power the RLYX board (Independent 24VAC /40VA Transformer)
- C. Not Used
- D. Not Used
- E. Not Used
- F. Load Terminals
- G. Communication link LED / Relay Status Lights

- H. Sync Button
- I. Not Used
- J. Not Used
- K. A1/B1 2 wire communication link, daisy chained OUT from RLYX to GEN X RM or RLYX
- L. A1/B1 2 wire communication link, daisy chained IN from GEN X or GEN X RM

**Board Relays are Pilot Duty*

ZONE THERMOSTAT

DESCRIPTION



The zone thermostat part# EzTouchX is a microprocessor based, auto changeover, programmable communicating zone thermostat. The zone thermostat controls modulating round or rectangular commercial modulating dampers. The communicating zone thermostat is used with the GEN X-VVT zoning system and communicates over 2-wire communication bus.

The zone thermostats control and modulate zone dampers based on variance from set point to a position that will match the supply load to the demand requirement. When the HVAC unit is running, if a zone thermostat is not calling or is calling for the opposite mode, its corresponding damper fully closes. When the HVAC unit is not running, the thermostats open to the Vent mode to provide ventilation, if the indoor blower fan is running continuously.

All zone thermostats are ID'd and communicate back to the GEN X controller. The GEN X mobile App interacts with the GEN X controller, via the Wi-Fi network and initiates control decisions for the system.

Through the GEN X mobile app you can coordinate global or individual schedules for the system, lock thermostats individually and provide a user interface to make adjustments and establish master temperature settings individually or globally for the system. This user interface provides diagnostic functions to streamline system troubleshooting along with air balance shortcuts, password protection and many additional functions.

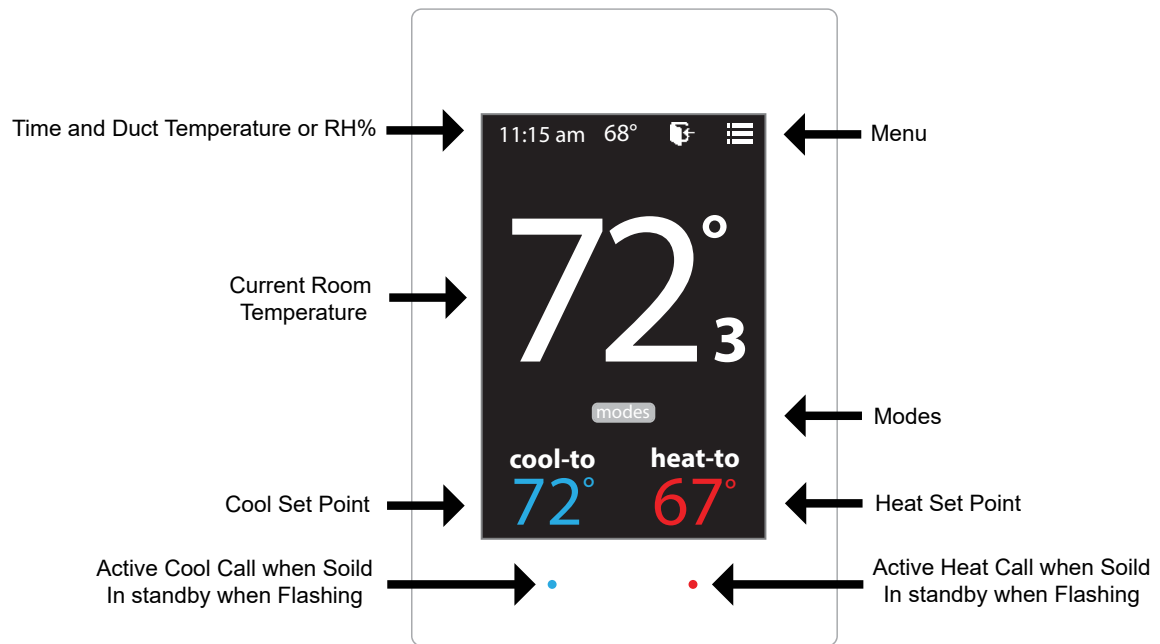

EzTouchX - Sequence of operation

COOL CALL

When zone temperature rises 1° or more degrees above COOL set point, thermostat transmits COOL call to the GEN X controller. GEN X controller evaluates calls for HEAT and COOL for majority vote. If there is a majority vote for COOL, GEN X controller initiates a call for cooling and the damper modulates open. **A BLUE light will flash** until system is operating in the COOL mode. Once system is in COOL mode, The BLUE light will remain constant. As zone cools, thermostat will communicate with the zone damper and modulate to maintain zone comfort. When zone temperature reaches set point, damper is closed or at minimum position and EzTouchX releases call for COOL.

HEAT CALL

When the zone temperature falls greater than 1 degree below HEAT set point, thermostat will initiate a call for HEAT. GEN X controller will evaluate all calls for HEAT and COOL in the system and if there is a majority of calls for HEAT, GEN X controller will initiate heat call and the damper modulates open. **A RED light will flash** until system is operating in the HEAT mode. Once system is in HEAT mode, The RED light will remain constant. As zone heat, thermostat will communicate with the zone damper and modulate to maintain zone comfort. When zone temperature reaches set point, damper is closed or at minimum position and EzTouchX releases call for HEAT.

Baseboard / Supplemental HEAT

When zone thermostat is configured for BASEBOARD heat and zone temperature falls greater than 2° below HEAT set point, the thermostat will energize AUX heat and BASEBOARD heat is now operating, When calling the RED light will remain constant. When zone temperature rises to HEAT set point, thermostat will satisfy call for AUX operations.

REHEAT

When zone thermostat is configured for REHEAT operation, and the zone temperature falls greater than 2° below HEAT set point, thermostat transmits a call for REHEAT. The EzTouchX modulates the damper to 40% open and energizes AUX output REHEAT, When calling the RED light will remain constant. When zone temperature rises to HEAT set point, thermostat satisfies, releases call for AUX REHEAT and closes damper.

VENT

When all calls for HEAT or COOL are satisfied, dampers will modulate to approx. 40% open and VENT will be displayed on thermostat indicating system is in ventilation mode.

INSTALLATION INSTRUCTIONS

Zone Damper Installation

Install dampers into HVAC duct so damper actuators are easily accessible. Damper may be mounted in an area where the ambient temperature is between 32 and 140 degrees Fahrenheit. Round dampers should be mounted with damper actuators between 9 and 3 O'clock position.

Installing 24VAC wiring

Once GEN X controller and supply dampers are installed, install one 24VAC/100VA transformer, and wire secondary 24 volts to the TR1 / TR2 bottom terminals on GEN X controller. Using 18 ga. thermostat wire, wire TR1 / TR2 top terminals and daisy chain power wires to the first zone thermostat. Continue daisy chain wiring from first thermostat to second, third, etc., until all zone thermostats are wired with power.

Note: Maintain TR1 and TR2 wiring polarity throughout the system to improve communications. DO NOT ground out the transformer.

Installing Communication Wire RS485

Once power wiring is daisy chained to all zone thermostats in the system, use Zonex STPR plenum rated twisted pair communications wire to install communications loop. Install communications wire using the A and B terminals on GEN X controller and daisy chain to the first zone thermostat in the system and wire to A and B terminals. Continue daisy chain to the next thermostat using A and B terminals to the A and B of the next thermostat, repeating this process until all zone thermostats are wired into the communications loop. Communications wiring is polarity specific, if RED communications wire is on A at the GEN X controller, then RED wire is connected to A throughout the system.

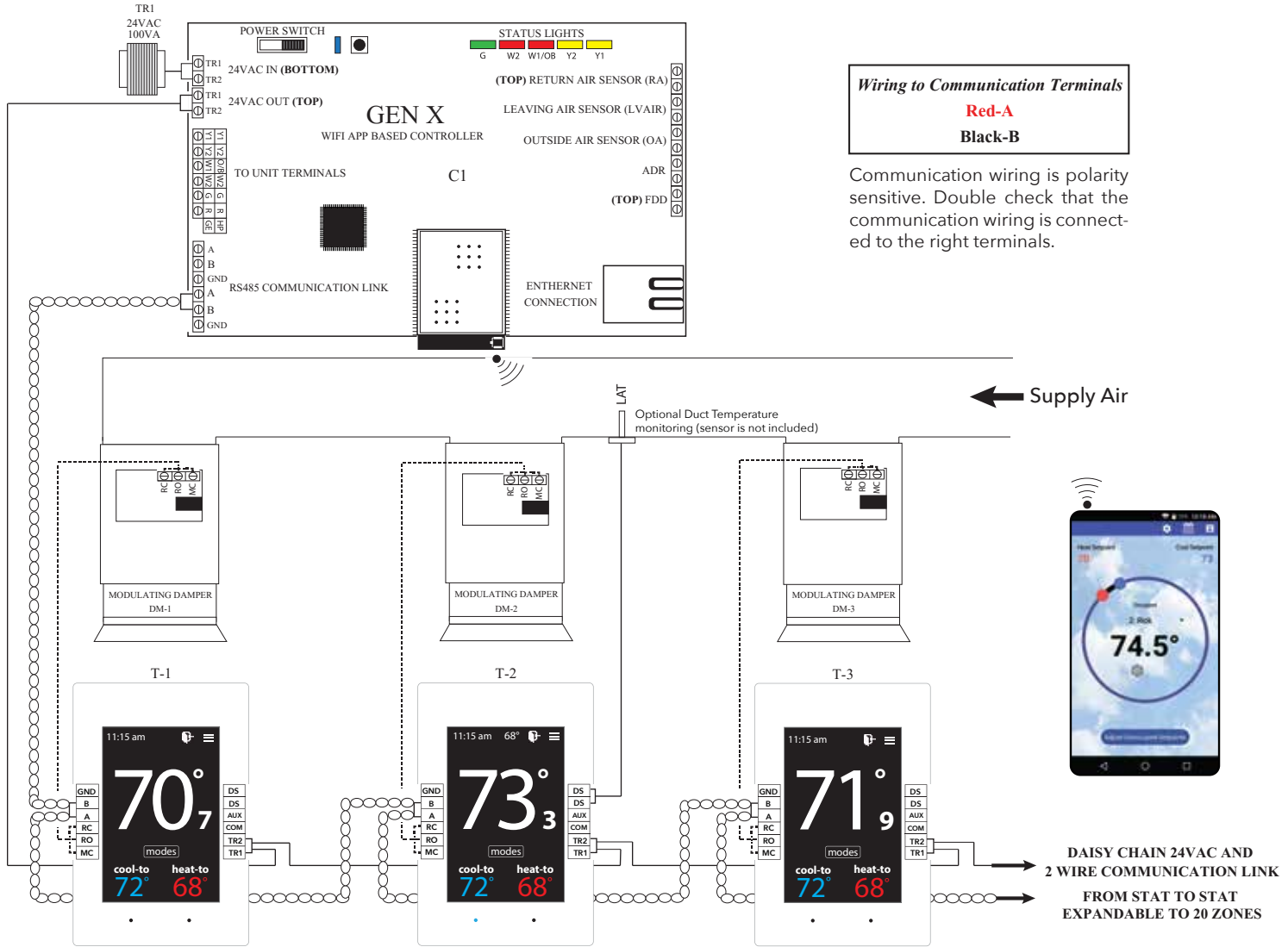

Wiring in the Leaving and Return Air Sensors to GEN X controller

The LAT Capacity Controller protects both the air conditioner and furnace by constantly monitoring the leaving air temperature. If the air gets too cold (drops below the cool cut-out set point), it breaks the "Y" connection, disengaging the compressor. If the air gets too warm (rises above the heat cut-out set point), it breaks the "W" connection, de-energizing the furnace. To prevent short cycling, the compressor or furnace cannot re-energize for at least 4 minutes after cut-out. The heating and cooling cut-out set points can be changed by the installer from the App.

Install Leaving Air Temperature Sensor (LAT) to the LVAIR terminals on the GEN X controller and place the sensor in the supply duct prior to the bypass takeoff. Install Return Air Temperature Sensor (LAT) to the RA terminals on the GEN X controller and place the sensor in the return duct after the bypass takeoff. **(Note: If extension of wire is needed, 18 ga. thermostat wire may be used).**

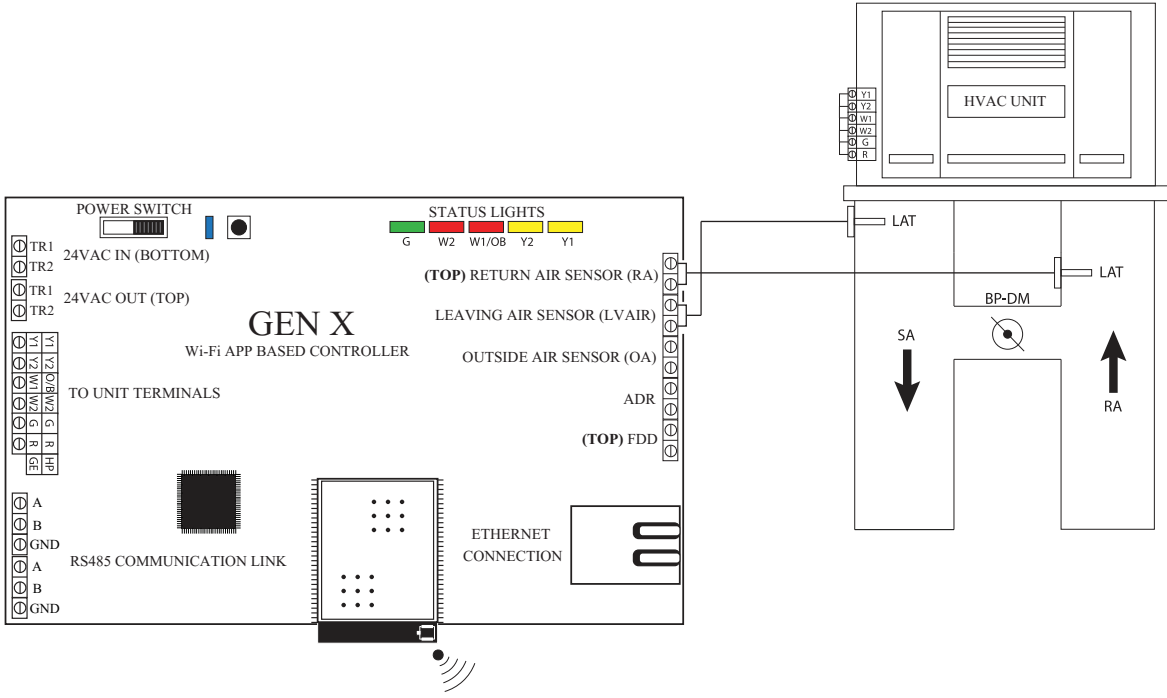

Wire Unit to GEN X Controller

Using standard 18 ga. thermostat wire, connect GEN X unit outputs to HVAC unit. Standard HVAC control terminal designations are used, R Y1 Y2 W1(O/B) W2 G, and energize HVAC unit.

1. Gas/Electric Wiring

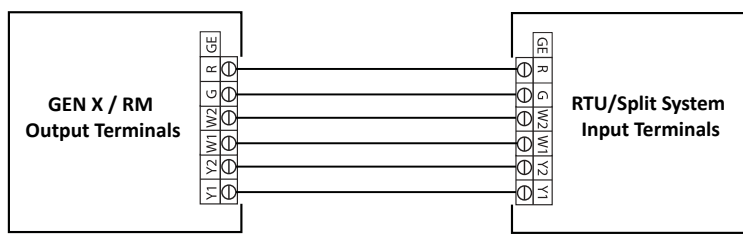

2. Heat Pump Wiring– O/B operation

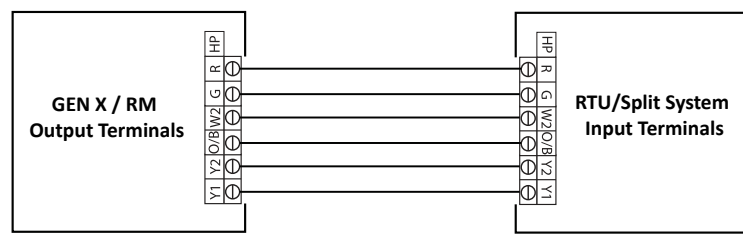

- Note:**
1. Single stage systems will not use Y2 or W2 terminals for operation. Please confirm your system operation to ensure proper wiring.
 2. For Heat Pump applications with Gas/Electric inputs, set system for gas operation and reset high limit on the App to 115 degrees.

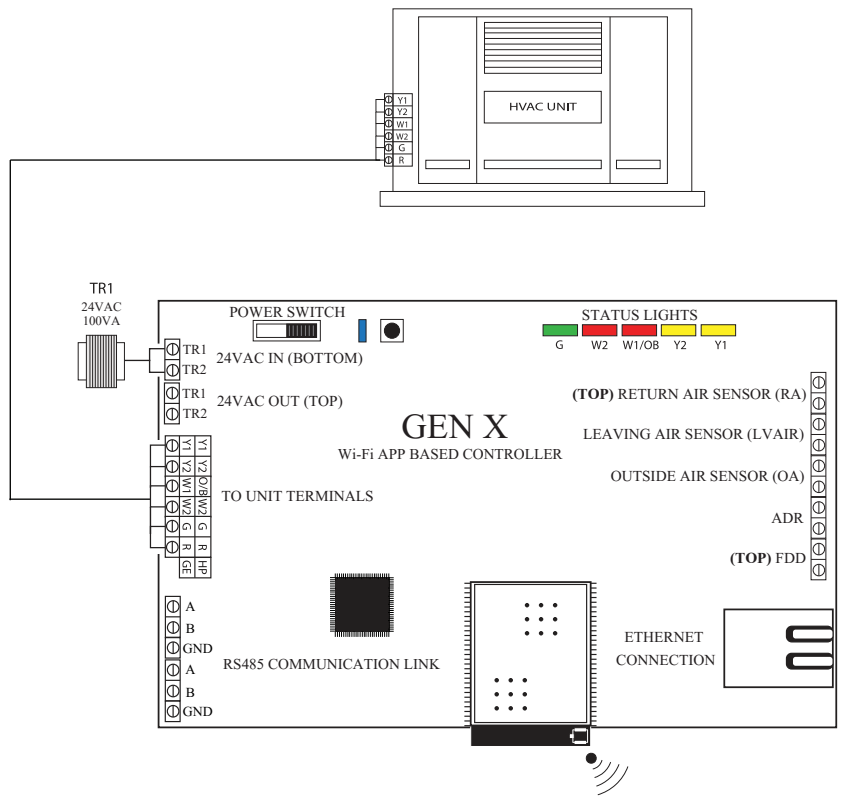

Note: GEN X does not control the unit economizer.

Wiring in the Automated Demand Response (ADR) to GEN X controller

ADR (Automated Demand Response) is a load shedding strategy implemented by local utilities to curb electricity usage during high demand periods. The local utility provider sends out a signal from a VTN or DRAS (Virtual Top Node or Demand Response Automated Server) from their facility and is received by a VEN (Virtual End Node) located at the customer's location. The purpose of the signal is to setback thermostat set points 4° for both the heating and cooling modes of the facility's HVAC equipment. **The GEN X does not directly accept signals from the local utility provider.** For the GEN X to setback thermostat set points it must be used in conjunction with a VEN hardware device that supports Open ADR (**contact the local utility provider for the most current protocol requirements for your area**) and must be equipped with a set of dry normally open contacts that close during an ADR event. The contacts of the VEN are wired to the ADR terminal of the GEN X (see diagram below). When the VEN receives an ADR signal from the VTN or DRAS its contacts close, the GEN X & RM's set back their thermostats 4° for both the heating & cooling modes and lock the thermostat set points so they cannot be adjusted at the thermostat during the ADR event. Once the ADR event has concluded the thermostats unlock and return to their original set points. For a list of Open ADR products please visit <http://products.openadr.org> or contact your local utility provider. This feature can be enabled/disabled on a thermostat by thermostat basis. Go to Settings ->Change ADR settings -> Check the boxes to enable ADR for that thermostat.

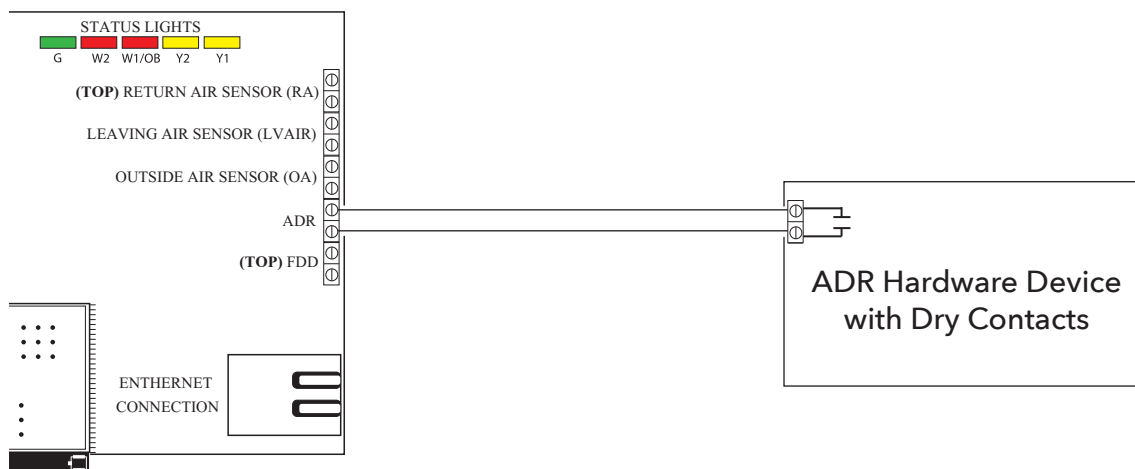

Wiring in the Fault Detection and Diagnostics (FDD) to GEN X controller

The purpose of the Fault Detection & Diagnostics (FDD) is to meet the requirement of Title 24 Part 6 section 120.2(i)6A in the event that a fault is detected by the economizer/unit controller so that appropriate facility personnel are notified. FDD must be triggered at the GEN X by a 24 VAC signal from the economizer/unit controller in the event of a fault. Facility personnel can receive FDD alerts via e-mail once they subscribe to alarms (see the Alarm Subscription Settings section on page 52). No additional configuration is required to make this feature operational. **Verify with the HVAC unit manufacturer that a 24 VAC for FDD alerting is provided prior to installation.**

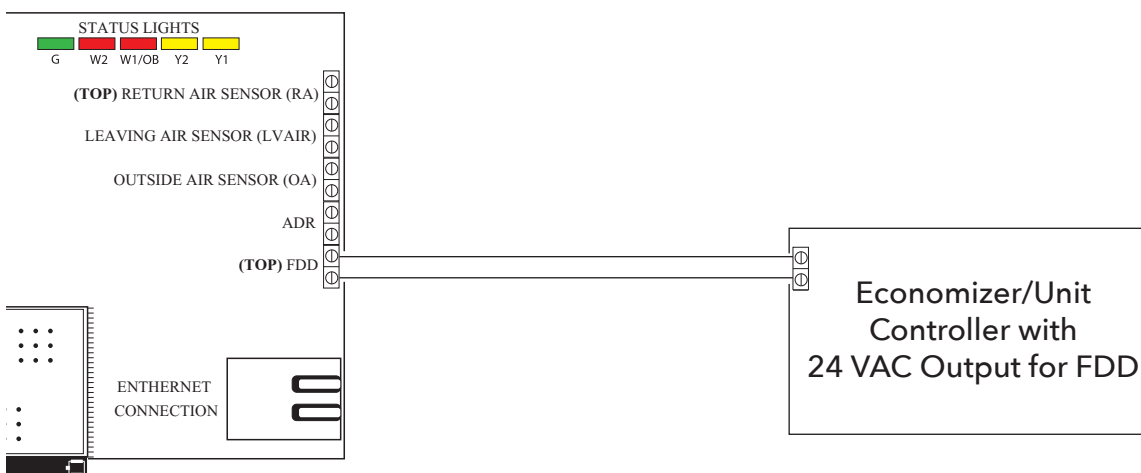

INSTALLATION INSTRUCTIONS

Wiring the GEN X to the GEN X RM

With the GEN X controller installed, if you have additional zoned RTU's or Split systems, install the GEN X RM expansion controller using the Zonex 2-wire twisted pair communication wire. Wire from the Gen X A, and B out to the GEN X RM A1 and B1 (IN) on the GEN X RM controller as shown below. If there are multiple GEN X RM's or RLYX's in the system, continue the Zonex 2-wire twisted pair in a daisy chain fashion from the GEN X RM to the next GEN X RM or RLYX. Note: Up to 20 GEN X RM's may be daisy chained to the Gen X controller.

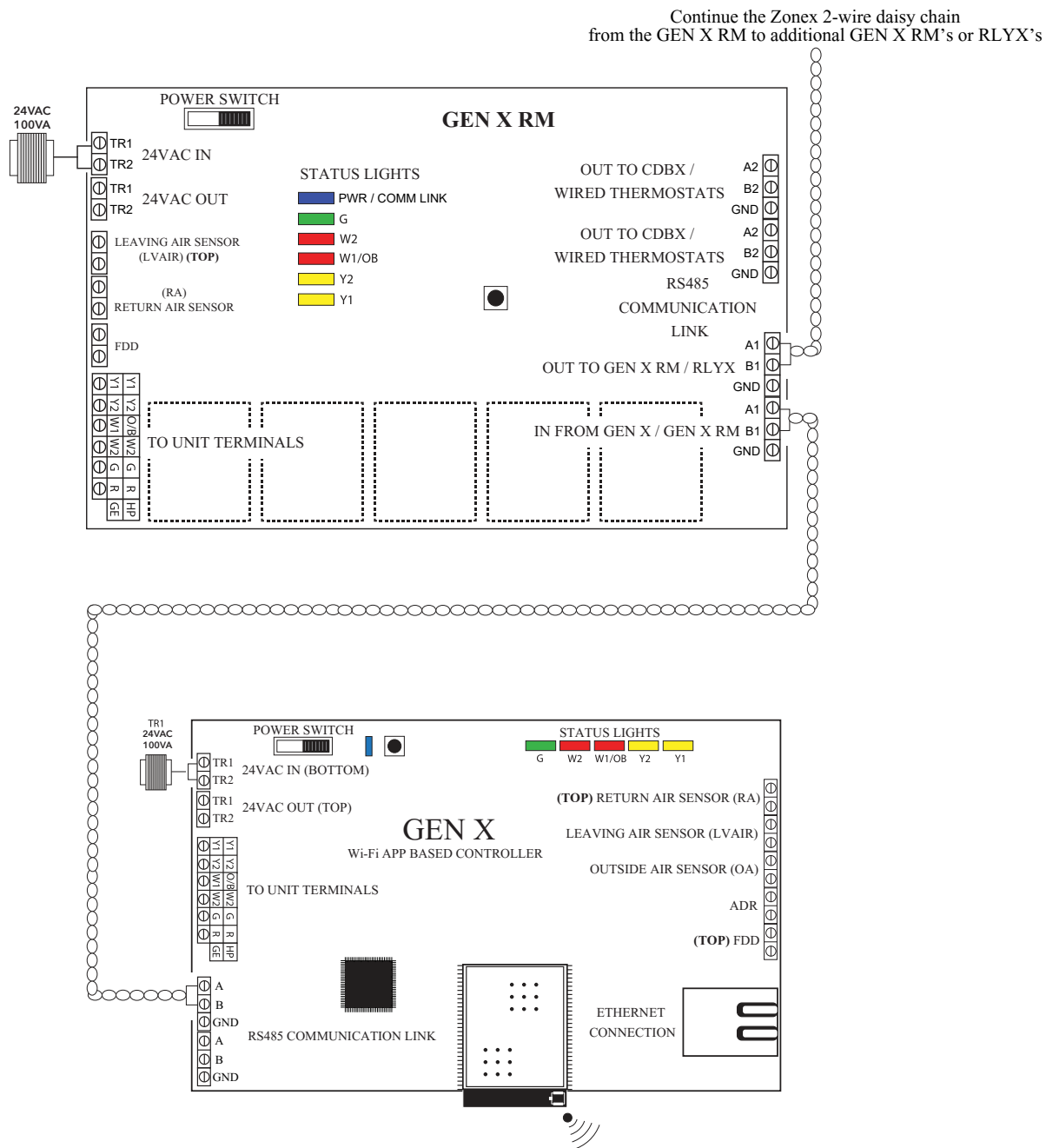

Zone Damper Installation

Install dampers into HVAC duct so damper actuators are easily accessible. Damper may be mounted in an area where the ambient temperature is between 32 and 140 degrees Fahrenheit. Round dampers should be mounted with damper actuators between 9 and 3 O'clock position.

Installing 24VAC wiring

Once RM controller and supply dampers are installed, install one 24VAC/100VA transformer and wire secondary 24 volts to the TR1 / TR2 top terminals on RM controller. Using 18 ga. thermostat wire, wire TR1/TR2 24VAC bottom terminals and daisy chain power wires to the first zone thermostat land on TR1 and TR2 (IN) terminals. Continue daisy chain wiring from TR1 and TR2 on first thermostat to TR1 and TR2 on second zone thermostat. Continue daisy chaining the wire to the third thermostat, and on until all zone thermostats are wired with power.

Note: Maintain TR1 and TR2 wiring polarity throughout the system to ensure effective communications. DO NOT ground out the transformer.

Installing Communication Wire RS485

Once power wiring is daisy chained to all zone thermostats in the system, use Zonex 2-TWP twisted pair communications wire to install communications loop. Install communications wire using the A2 and B2 terminals on GEN X RM controller and daisy chain to the first zone thermostat in the system wiring to A and B terminals. Continue daisy chain to the next thermostat using A and B terminals to the A and B of the next zone thermostat, repeating this process until all zone thermostats are wired into the communications loop. Communications wiring is polarity specific, if RED communications wire is on A at the RM controller, then RED wire is connected to A throughout each damper board in the system.

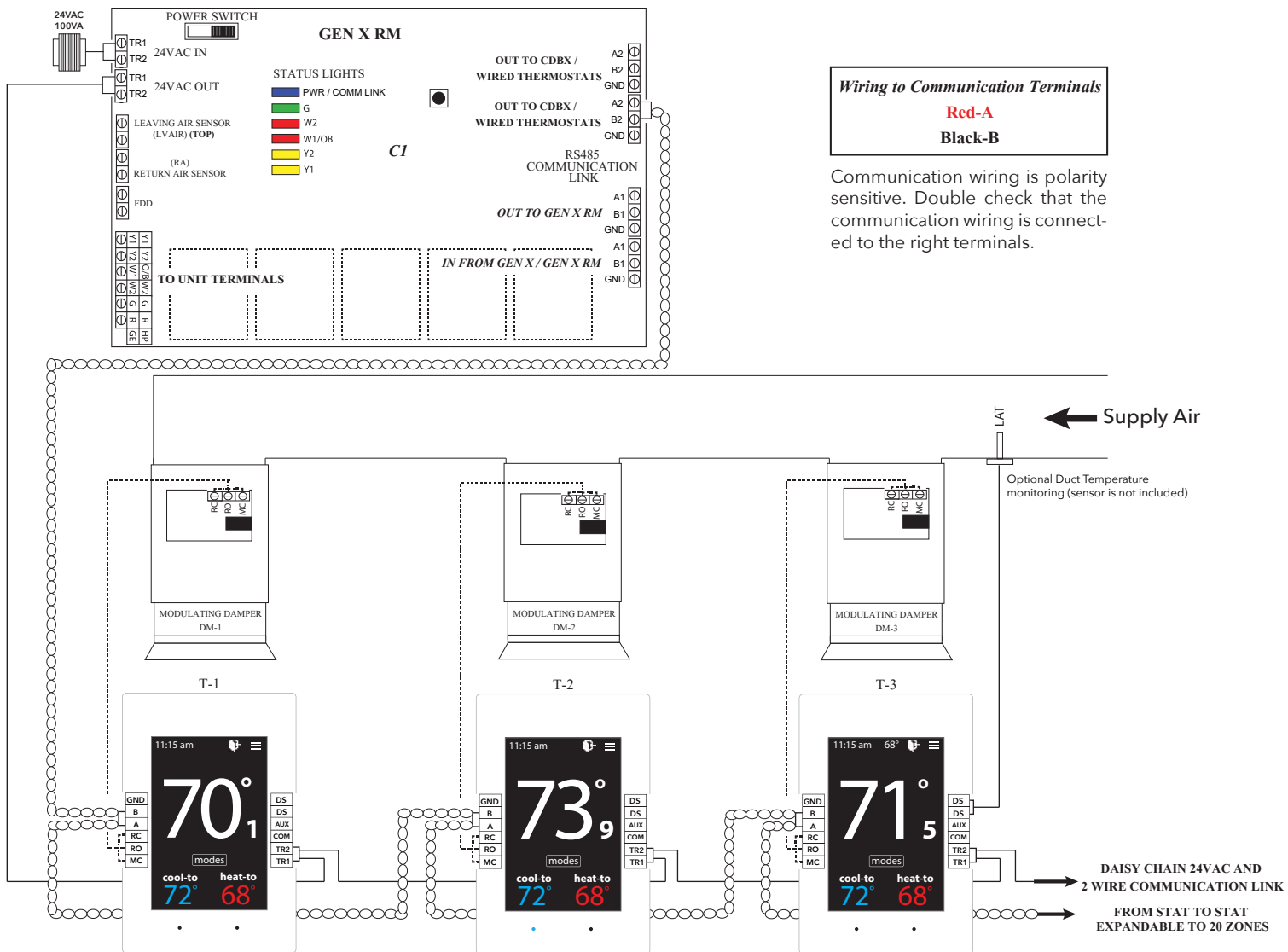

Wiring in the Leaving and Return Air Sensors to GEN X RM Controller

Install Leaving Air Temperature Sensor (LAT) to the LVAIR terminals on the RM controller and place the sensor in the supply duct prior to the bypass takeoff. Install Return Air Temperature Sensor (LAT) to the RA terminals on the RM controller and place the sensor in the return duct after the bypass takeoff.

(Note: If extension of wire is needed, 18 ga. thermostat wire may be used).

Note: GEN X RM does not control the unit economizer.

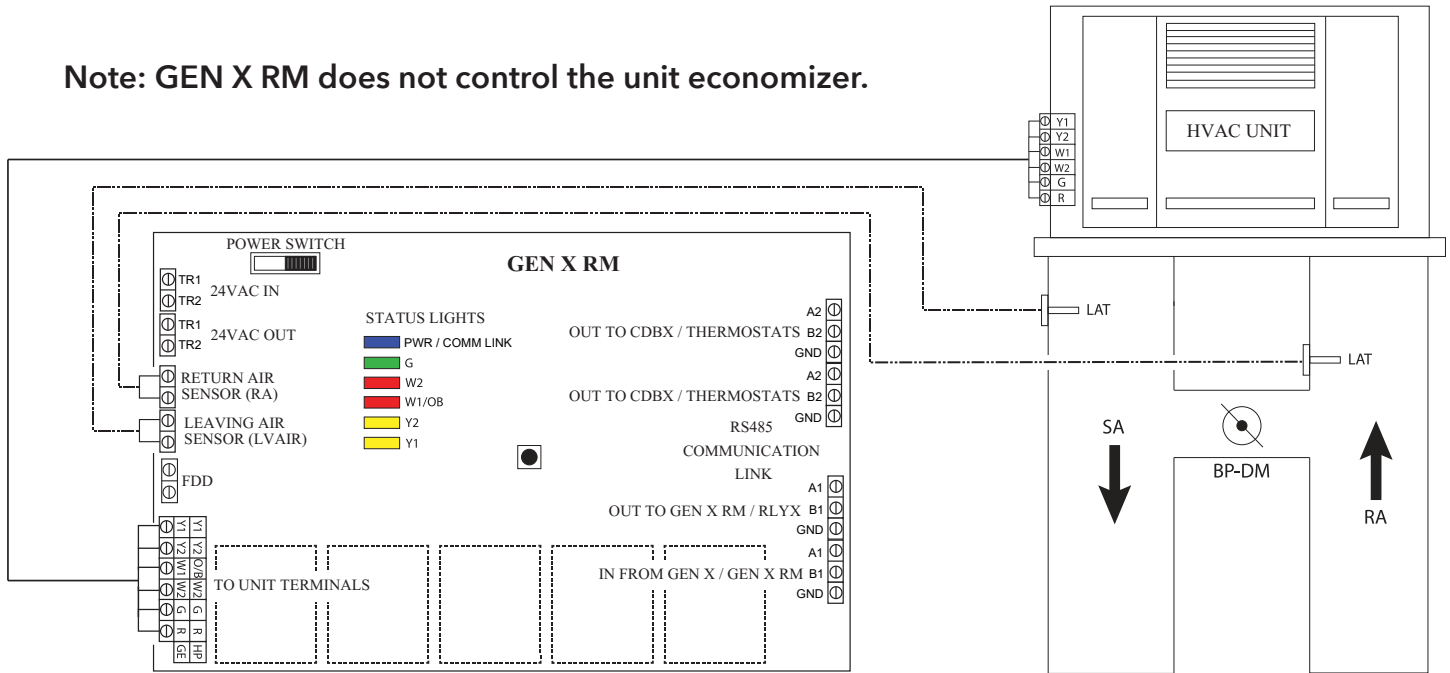

Wire Unit to GEN X RM Controller

Using standard 18 ga. thermostat wire, connect RM unit outputs to HVAC unit. Standard HVAC control terminal designations are used, R Y1 Y2 W1(O/B) W2 G, and energize HVAC unit.

1. Gas/Electric Wiring

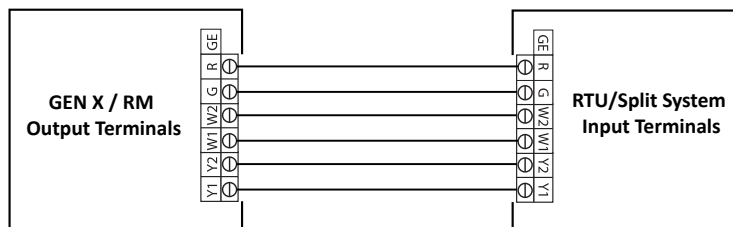

2. Heat Pump Wiring– O/B operation

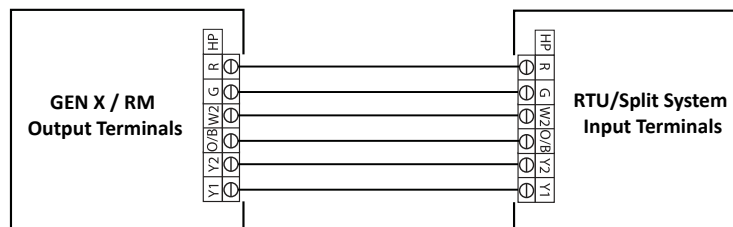

Note: 1. Many systems are single stage and will not use Y2 or W2 terminals for operations.

Please confirm your system operation to ensure proper wiring.

2. For Heat Pump applications with Gas/Electric inputs, set system for gas operation and reset high limit on the app to 115 degrees.

Wiring in the Fault Detection and Diagnostics (FDD) to GEN X RM controller

The purpose of the Fault Detection & Diagnostics (FDD) is to meet the requirement of Title 24 Part 6 section 120.2(i)6A in the event that a fault is detected by the economizer/unit controller so that appropriate facility personnel are notified. FDD must be triggered at the GEN X RM by a 24 VAC signal from the economizer/unit controller in the event of a fault. Facility personnel can receive FDD alerts via e-mail once they subscribe to alarms (see the Alarm Subscription Settings section on page 58). No additional configuration is required to make this feature operational. **Verify with the HVAC unit manufacturer that a 24 VAC for FDD alerting is provided prior to installation.**

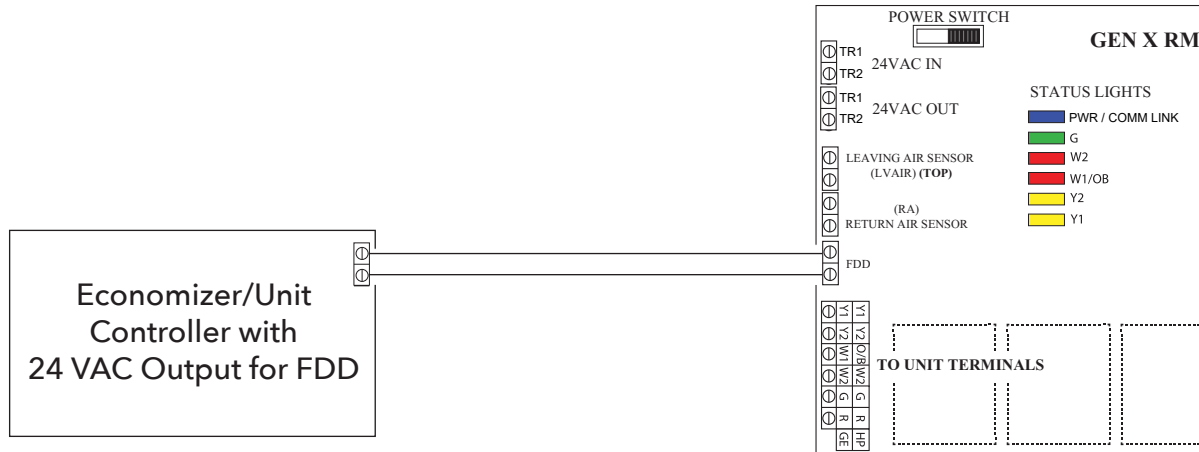

Installing 24VAC wiring

Once the RLYX controller is installed, install one 24VAC 40VA transformer and wire secondary 24 volts to the TR1 / TR2 (IN) terminals on RLYX controller. Using 18 ga. thermostat wire.

Note: Maintain TR1 and TR2 wiring polarity throughout the system to ensure effective communications. DO NOT ground out the transformer.

Installing Communication Wire RS485

Using Zonex 2-TWP twisted pair communications wire to install communications loop. Install communications wire using the A and B IN from GEN X / GEN X RM terminals on RLYX controller. Continue daisy chain from the OUT to GEN X RM / RYLX terminals using A and B to the A and B IN on the next GEN X RM / RYLX controller, repeating this process until controllers are wired into the communications loop. Communications wiring is polarity specific, if RED communications wire is on A at the RYLX controller, then RED wire is connected to A throughout controls communications loop.

Wiring in the 24VAC Coil Relay's and Relay Transformer

Install a second independent 24VAC 40VA transformer, using 18 ga wire run one side of the 24VAC to "COM" on the RYLX load terminals. Install a field supplied 24VAC coil relay and wire in the other leg of the 24VAC transformer to one side of the 24VAC coil on the relay or relay's.

Now wire from "R1" off the RYLX load terminal strip using 18 ga wire to the other side of the 24VAC coil relay, this should complete the circuit for the "R1" load. Repeat the steps above for any additional relay's using load terminals "R2, R3, R4 or R5".

Wire in the generic load power so that the relay breaks the loads power. Wire in all generic loads to meet local code requirements.

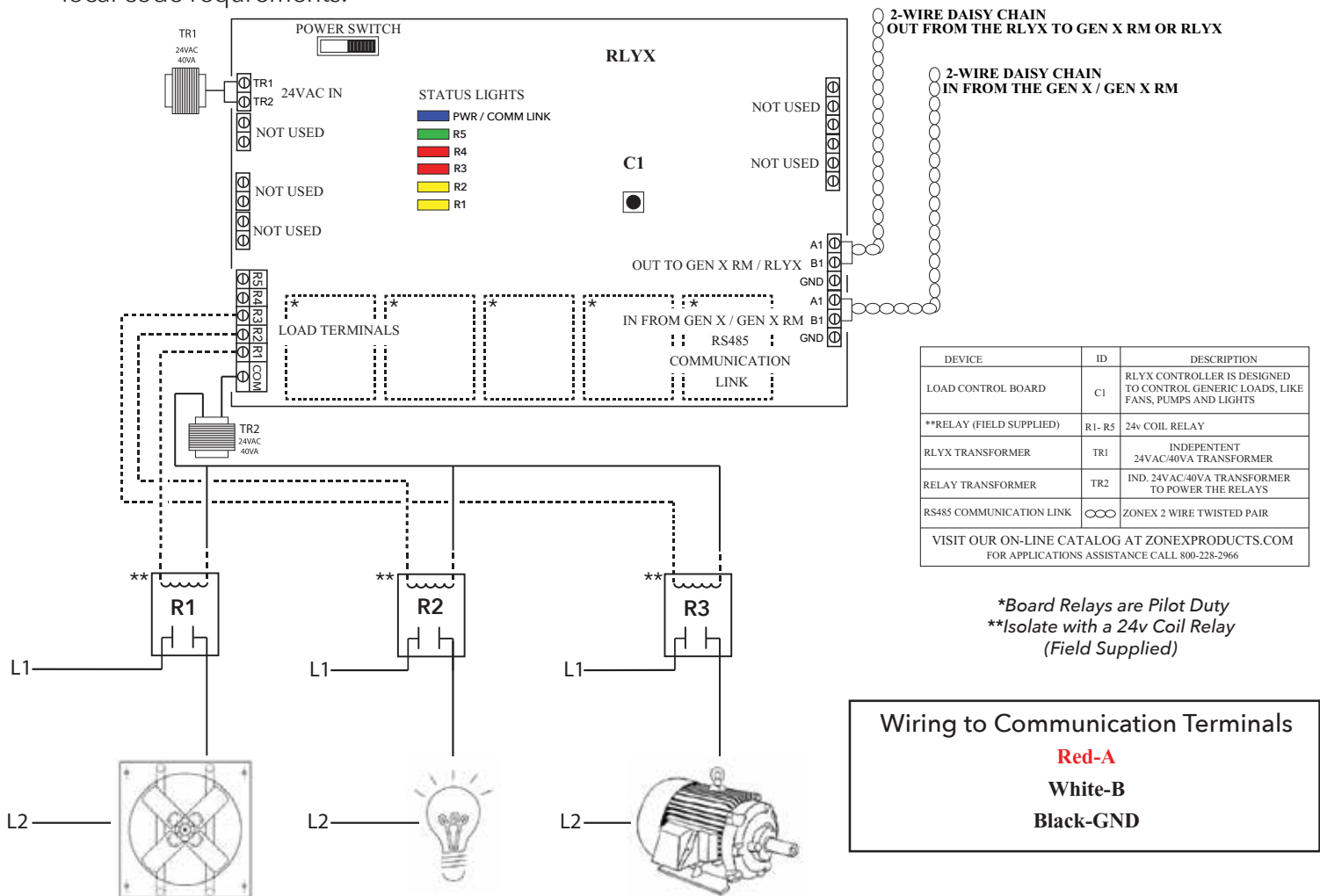

Setting ID on the EzTouchX Thermostat

Each thermostat must be ID'd. Beginning with the first thermostat in the daisy chain closest to the GEN X controller, place provided white label #1 on the damper. Locate associated zone thermostat and confirm display appears on stat. If not, turn ON the GEN X and GEN X RM controllers at the ON/OFF switch located on the left hand corner of the controllers. If no display is seen, check that you have 24VAC between TR1 and TR2 on the GEN X controller and then at the thermostat.

To access the Thermostat Advanced Menu: Tap on the degree symbol next to the room temp

The degree symbol will change color from white to green and then tap

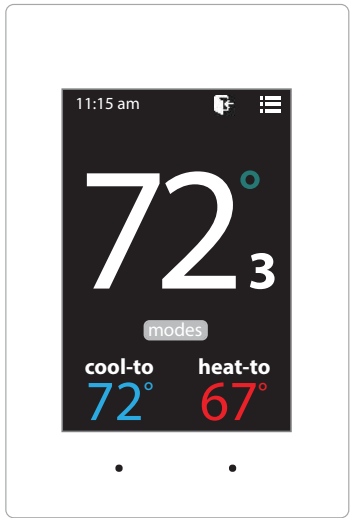

Setting STAT ID for the Zone Thermostat

While in the Thermostat Advanced Menu, Select **SET ID**

Use the and arrows to set the new ID ranging from 1-20

Tap to save changes, to return to the home screen tap

Note: (All thermostats receive a unique ID 01 to 20, maximum of 20 zones per GEN X and GEN X RM controllers.)

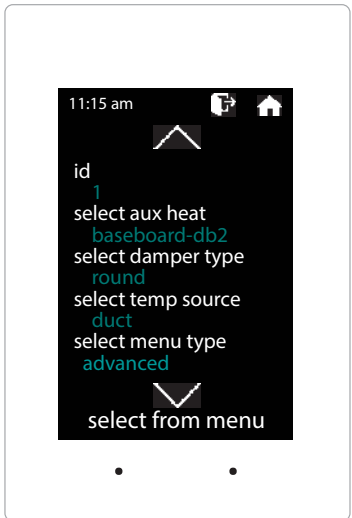

The GEN X mobile App provides local or remote access to your system, providing direct access to zoned systems or stand alone units.

Download and install the GEN X App on your mobile device from Google Play or Apple App Store.

Connect an Ethernet cable from the customer's network into the GEN X's Ethernet connection (this should be provided by the customer). (Skip the step below if you were able to connect to the customer's network.)

If a network connection is not available please go to pg 45 for direct wireless setup instructions.

Ensure that your mobile device is connected to the same network as the GEN X via a Wi-Fi connection. If you are connecting to the customer's network then you must obtain the network name /SSID and password (you may need to contact your customer's IT personnel).

Open the Zonex App and tap the "SCAN LAN FOR GEN X" icon at the bottom of the screen.

Allow the App time to scan the network for the GEN X control board (this could take up to 60 seconds).

You will then see the message "Tap to select your local GEN X system" at the top of the App. Tap the down arrow on the right and a drop down menu will appear indicating the GEN X or RM system(s) connected to the network. If no GEN X is listed power off the GEN X for a few moments, power it back on and reopen the Zonex App so the scan process can be restarted. **Note:** You only need to scan once, after you have successfully scanned and found the GEN X controller. The GEN X app will remember the IP address and load it the next time you log in.

Select the GEN X or RM you wish to access by tapping on it.



COMMISSIONING AND STARTUP

Once GEN X controller is mounted, and zone stats are ID'd the system is ready to be commissioned and started up. Turn on the GEN X controller and confirm the blue power light is ON.

Confirm Thermostat Communications

Open the Gen X app, tap the for System Configuration Menu and tap Configure Number of Thermostats / Dampers. Enter the number of zones that are in the system. While still in the Configuration menu tap System Diagnostic and confirm that all the zones are showing Active under the thermostat status. If it shows Err: Check wiring / Stat ID confirm wiring is correct and check Stat ID.

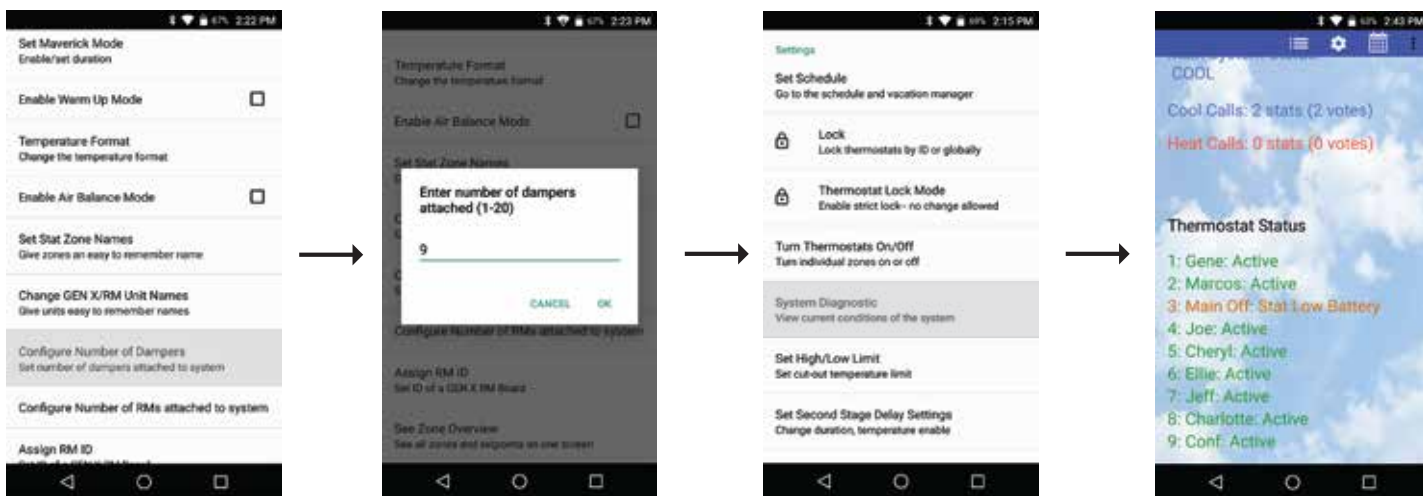

Set Type of Unit

Confirm the type of unit the GEN X is controlling: GAS, ELECTRIC, HEAT PUMP (O), or HEAT PUMP (B). Factory default for UNIT TYPE is GAS, if application is ELECTRIC or HEAT PUMP, you will need to adjust this through the mobile App. Select Unit Type in the configuration menu, tap Heat Pump O/B or Electric.

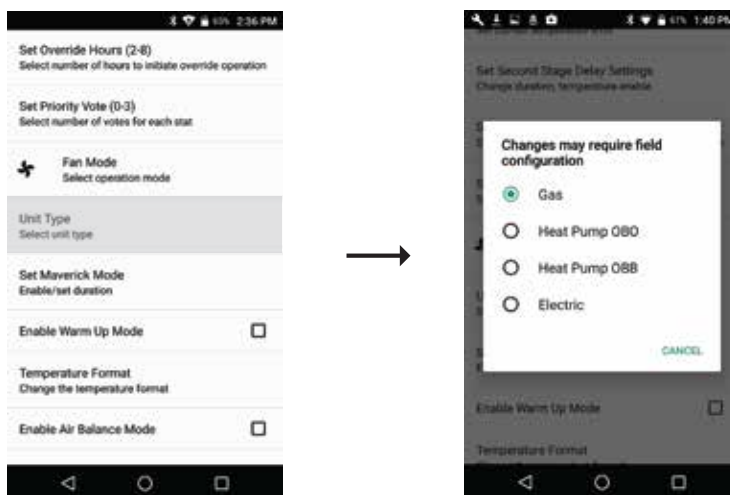

Confirm High/Low Limits

Factory defaults for GAS/ELECTRIC units are set for 40 degrees Low Limit and 145 degrees High Limit. Heat Pump O and B machines are set for 40 degrees Low Limit and 115 degrees High Limit. These may be adjusted in the field to meet unit specification. To confirm or adjust, use the mobile app to access the configuration menu. Select High/Low Limits, tap High or Low limit and confirm limit set point.

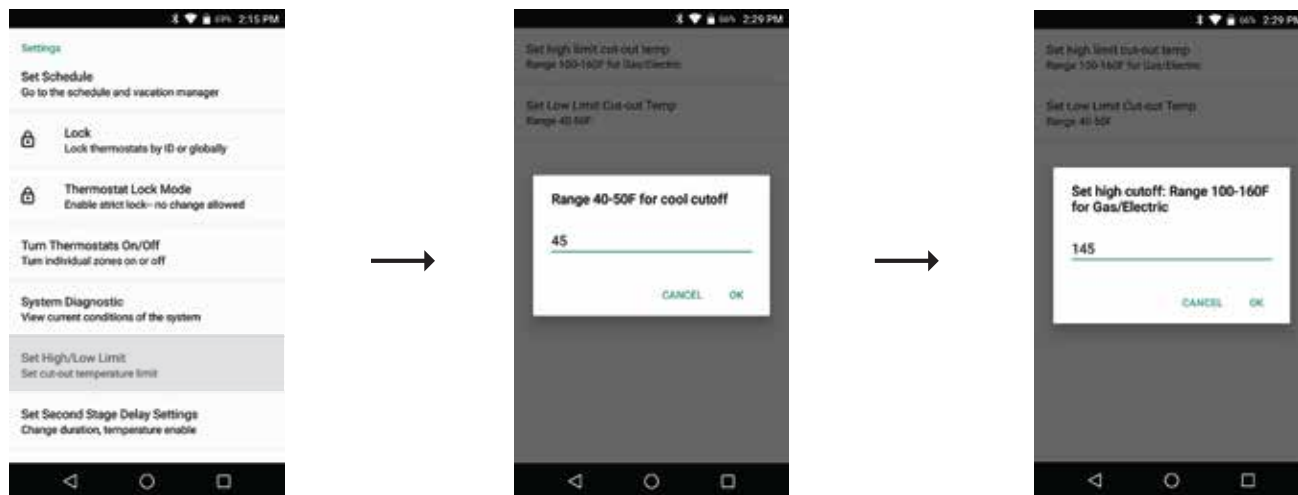



*Check the RTU / Split System's High / Low Limits and adjust them on the GEN X / GEN X-RM below the units cut out limit.

Set Fan Operation

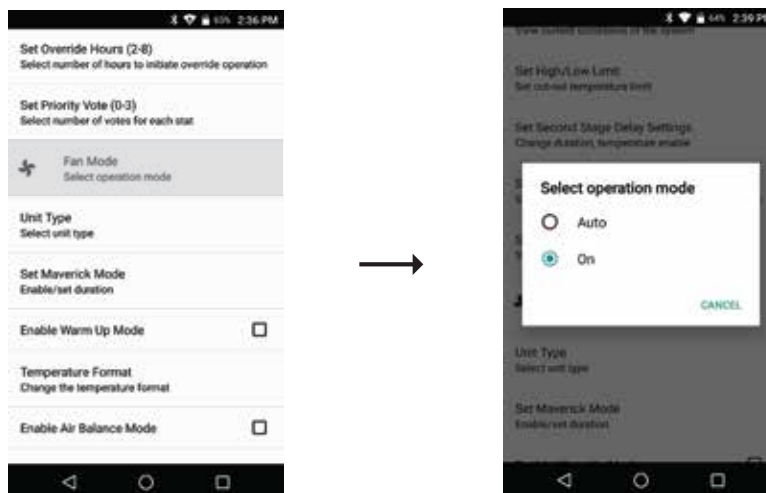
Configuration of FAN is set at the factory for AUTO operation. When there is a call for HEAT or COOL, fan will run. If continuous fan is required, fan will need to be configured for fan ON and will run anytime during Occupied time, and AUTO during unoccupied. To set fan mode, using the Mobile App access the configuration menu. Tap FAN mode, choose AUTO or ON.



Confirm Cool Call and Damper Operation

Open the Gen X app and go to the Zone overview screen , select Zone 1 by tapping on that zone. The Ring of Comfort screen should appear. Tap on  in the middle of the ring and choose All Zones. Slide or Drag the Blue circle counter clockwise to drop the temperature below the current room temperature. Tap back on the phone to return to zone overview screen. All zones should have a current room temperature that is blinking blue, indicating a cool call. Within 2 minutes, a call for cooling will be made from GEN X controller. Confirm Y1 and G lights are on at the GEN X controller. Go to each zone and confirm damper is open and "ON" appears on thermostat display indicating an active cool call. Once all dampers are confirmed open, satisfy cooling calls at each zone thermostat. At each zone stat, raise COOL set point by using the UP button to raise the set point. Confirm "ON" disappeared and damper closes once call is satisfied. Continue to satisfy all cool calls one at a time until all calls are satisfied and dampers are closed. If damper does not close confirm power and communication wiring installation. Within 1 minute of all calls satisfying Y1 will de-energize, and a 3 minute purge follows, no calls are allowed during this time.

OVERVIEW SCREEN





RING OF COMFORT

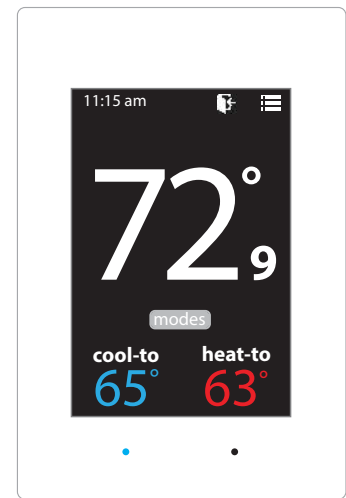

▼ ACCESS ALL THERMOSTATS



Confirm Heat Call and Damper Operation

Open the Gen X app and go to the Zone overview screen , select Zone 1 by tapping on that zone. The Ring of Comfort screen should appear. Tap on  in the middle of the ring and choose All Zones. Slide or Drag the Red circle clockwise to raise the temperature above the current room temperature. Tap back on the phone to return to zone overview screen. All zones should have a current room temperature that is blinking Red indicating a heat call. Within 2 minutes a call for heating will be made from GEN X controller and confirm W1(Y1 for HP) light is on at the GEN X controller. Go to each zone and confirm damper is open and "ON" appears on thermostat display indicating an active heat call. Once all dampers are confirmed open, satisfy heating calls at each zone thermostat. At each zone stat, lower heat set point by using the DOWN button to lower the set point. Confirm "ON" disappears and damper closes once call is satisfied. Continue to satisfy all heat calls one at a time until all calls are satisfied and dampers are closed. If damper does not close confirm power and communication wiring installation. Within 1 minute of all calls satisfying W1 (Y1 for HP) will de-energize, and a 3 minute purge follows, no calls are allowed during this time.

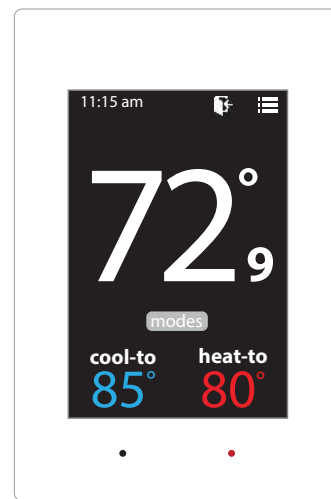
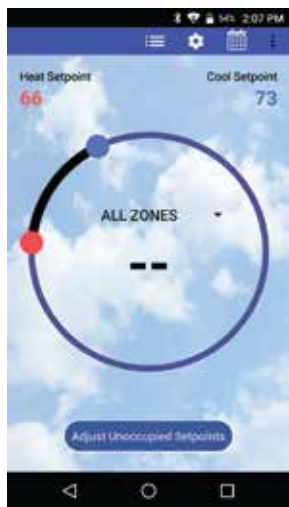

Vent

With all calls satisfied all dampers modulate to VENT position, approximately 40% open, confirm stat display indicates "VENT".

Syncing the GEN X RM to the GEN X Controller

Each RM controller communicates to the GEN X over an RS-485 communications bus. GEN X is the communications hub for the system providing time clock functions along with interpreting any calls or system updates at the RM level and communicates that information to the cloud. Each RM controller must be synced with the GEN X controller to communicate and transmit information to and from the mobile App.

Connect to the GEN X via the mobile app. Go into the "System Configuration Menu" and tap "Configure Number of RM's Attached to System". Enter the number of GEN X RM's wired to the GEN X controller.

While still in the "System Configuration Menu", tap "Assign RM ID". Enter 1 for the first GEN X RM in the system and press "OK". When the Blue light starts flashing on the GEN X RM controller, press and hold the sync button on the GEN X RM board for 15 seconds. When the light stops flashing the sync has been completed.

Repeat the "Assign RM ID" for each additional GEN X RM in the system, making sure to increase the RM ID for each GEN X RM. For example, if you have 7 GEN X RM's in the system they will be ID'd 1-7 in the order of how the communication wire is daisy chained.



Enter number of RMs attached to the system (1-20)



Each RM needs to be assigned its own ID

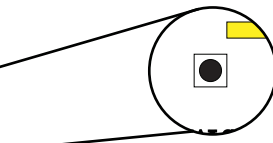
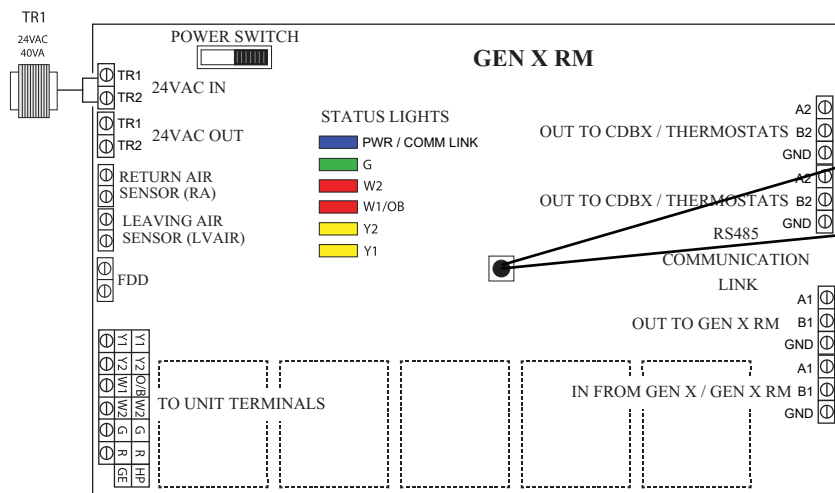

After assigning the RM with its ID wait for the Blue communication light to start blinking rapidly and then press and hold the sync button for 15 seconds.

Syncing the RLYX to the GEN X Controller

Each RLYX controller communicates to the GEN X over an RS-485 communications bus. GEN X is the communications hub for the system providing time clock functions along with interpreting any calls or system updates at the RLYX and communicates that information to the cloud. Each RLYX controller must be synced with the GEN X controller to communicate and transmit information to and from the mobile App.

Connect to the GEN X via the mobile app. Go into the "System Configuration Menu" and tap "Configure Number of RLYX's Attached to System". Enter the number of RLYX's wired to the GEN X controller.

While still in the "System Configuration Menu", tap "Assign RLYX ID". Enter 1 for the first RLYX in the system and press "OK". When the Blue light starts flashing on the RLYX controller, press and hold the sync button on the RLYX board for 15 seconds. When the light stops flashing the sync has been completed.

Repeat the "Assign RLYX ID" for each additional RLYX in the system, making sure to increase the RLYX ID for each RLYX. For example, if you have 3 RLYX's in the system they will be ID'd 1-3 in the order of how the communication wire is daisy chained.



Enter number of RLYX's attached to the system (1-20)



Each RLYX needs to be assigned its own ID

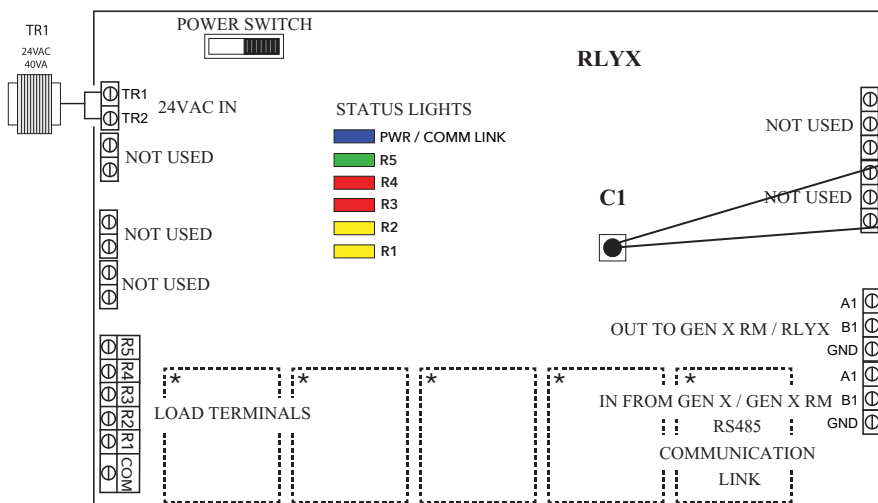

After assigning the RLYX with its ID wait for the Blue communication light to start blinking rapidly and then press and hold the sync button for 15 seconds.

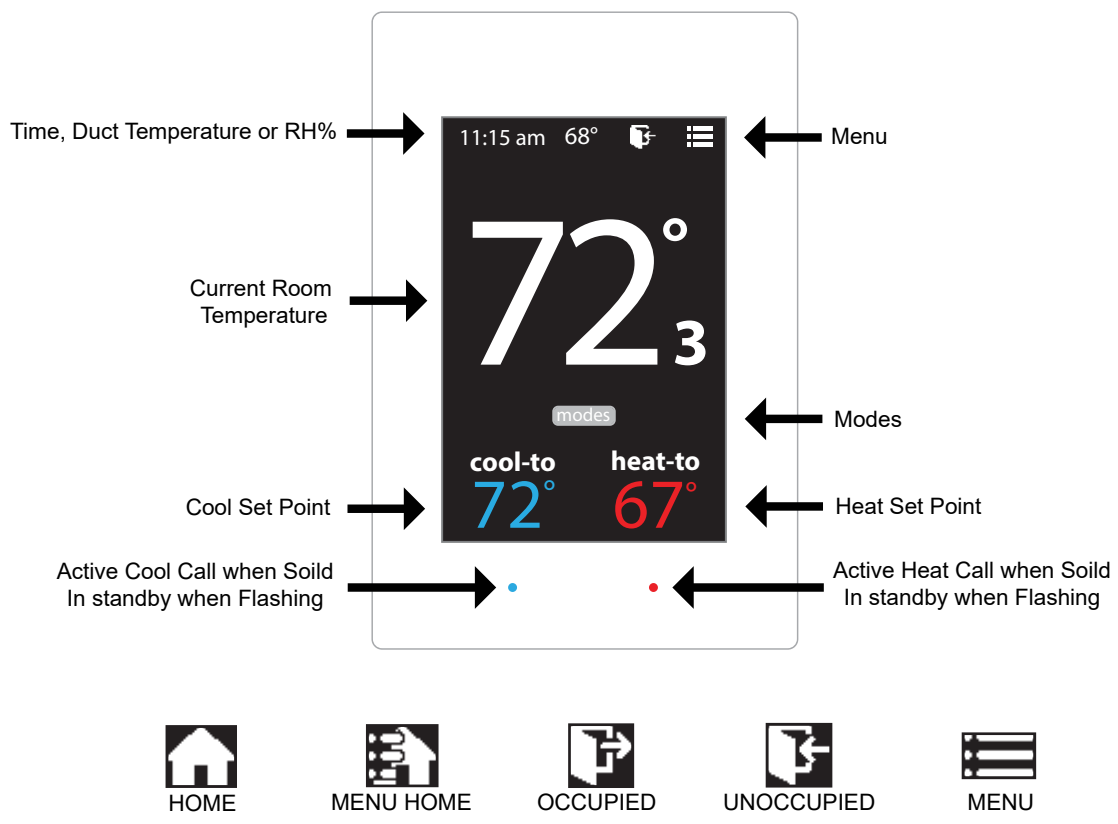

Addressing Zone Thermostats

Every thermostat in the system needs a unique ID ranging from 1-20. They must be in numerical order the way the communication wire is daisy chained. Confirm no duplicate addresses.

To set the stat's ID access the Advanced Configuration menu by tapping on the degree symbol next to the room temp . The degree symbol will change from white to green and then tap

Once in the Thermostat Advanced Menu, Select **SET ID**

Use the and arrows and set the new ID ranging from 1-20

Tap to save changes, to return to the home screen tap

Select Damper Type

The EzTouchX needs to be configured for the type of damper that it is wired to. There are 4 options, round, rectangular, spring loaded or vrf.

To set the damper type access the Advanced Configuration menu by tapping on the degree symbol next to the room temp . The degree symbol will change from white to green and then tap

While in Thermostat Configuration Menu, Select **Damper Type**

Select round, rectangular, spring loaded or vrf damper operation



Tap to save changes, to return to the home screen tap



Display Temperature Calibration

Thermostats are calibrated at the factory and should require no further adjustment. However, the display space temperature may be field calibrated by the following procedure:

To access the Thermostat Configuration Menu: Tap 

While in Thermostat Configuration Menu, Select **Calibrate Display**

Use the  and  arrows to calibrate the thermostat display to a external temperature probe temperature reading.

Tap  to save changes, to return to the home screen tap 

Adjusting Set Points

The Heat or Cool set points are displayed at the bottom of the screen. To adjust the set points, tap on the heat-to or cool-to temperatures; the set points will be displayed on the screen.

Use the  and  arrows over the flame/snowflake icons to set the desired heat and cool set points.

Tap  to save changes

Changing Mode

The thermostats are auto changeover, but specific modes may be selected. Heat/Cool mode is the default.

System Heat/Cool - Tap on , select "Heat/Cool". Tap  to save changes

System Heat Only - Tap on , select "Heat Only". Tap  to save changes

System Cool Only - Tap on , select "Cool Only". Tap  to save changes





System Off - Tap on , select "Off". Tap  to save changes

Override Operation

When the thermostat displays the unoccupied icon  a 2-hour temporary override may be initiated by tapping the  "Override" will appear. When additional override time is required, tap the unoccupied icon again.

Auxiliary Heat / Reheat

The zone thermostat provides the following Auxiliary Heat options; Baseboard, Baseboard W1 and Reheat (see figure on the following page for more details) with configurable dead band of 2°, 3°, or 4°. **Note: Reheat has a fixed 2° dead band. And when using in duct electric strip heater, an airflow proving switch is required for safe operation.**

Configuration of Auxiliary Heat/Reheat is accomplished by selecting "SELECT AUX HEAT" function in the Advanced Menu. To access the Advanced Menu tap the  degree symbol of the room temperature (the degree symbol should change color to green) then tap the  in the upper right corner of the thermostat, Tap "Select Aux Heat", Select the desired Auxiliary Heat/Reheat and dead band (2°, 3°, or 4°). Tap on  to save desired settings. To return to the home screen tap 

THERMOSTAT USER MENU

To access the Thermostat User Menu: Tap

The **THERMOSTAT USER MENU** allows you to:

Select Occupied Light

Calibrate Display

Time & Date (view only)

Select Unoccupied Light

Temperature F/C (view only)

Set Display Accuracy

Current Schedule (view only)

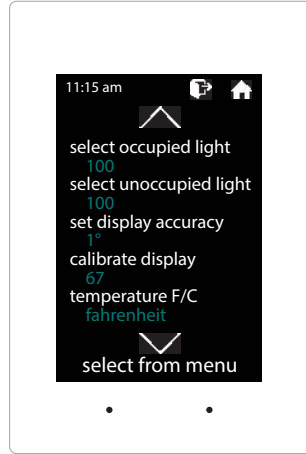
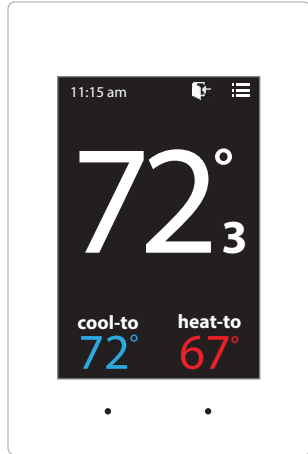

SELECT OCCUPIED LIGHT

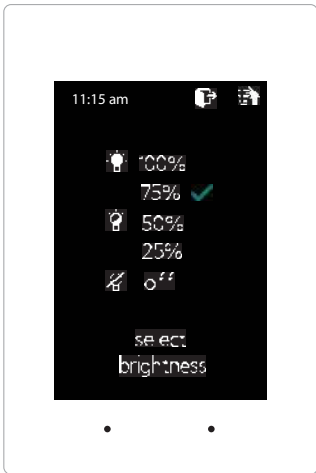

The brightness of the thermostat during occupied mode is adjustable from 100% down to off.

While in Thermostat Configuration Menu, Select **Occupied Light**

Select the desired brightness.

Tap to save changes, to return to the home screen tap

Note: If "off" is selected, just touch stat to wake it up.

SELECT UNOCCUPIED LIGHT

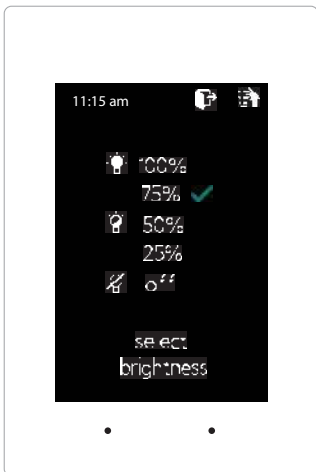

The brightness of the thermostat during unoccupied mode is adjustable from 100% down to off.

While in Thermostat Configuration Menu, Select **Unoccupied Light**

Select the desired brightness.

Tap to save changes, to return to the home screen tap

Note: If "off" is selected, just touch stat to wake it up.

SET DISPLAY ACCURACY

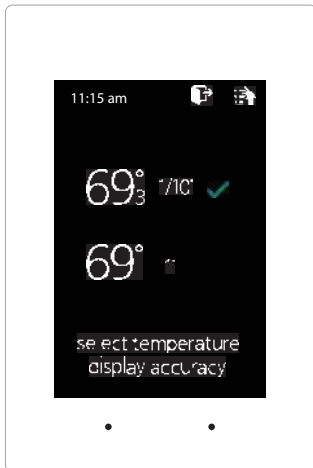

Display accuracy allows the thermostat to display the room temperature in 1/10° or 1°.

While in the Thermostat Configuration Menu, Select **Set Display Accuracy**

Select the desired display accuracy

Tap to save changes, to return to the home screen tap

CALIBRATE DISPLAY

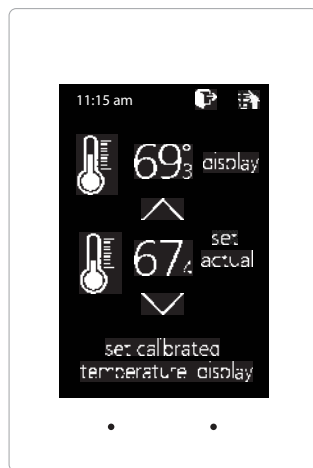

Thermostat is equipped with an accurate temperature sensor. If you require field calibration, follow the steps below.

While in Thermostat Configuration Menu, Select **Calibrate Display**

Use the and arrows to calibrate the thermostat display to a external temperature probe temperature reading.

Tap to save changes, to return to the home screen tap

TEMPERATURE F/C

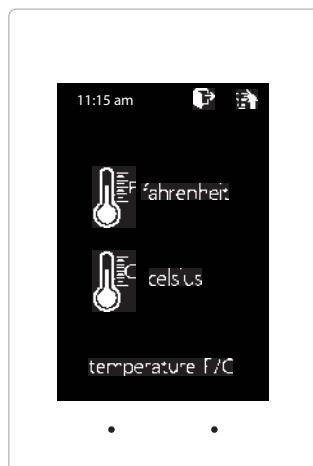

Thermostats can be configured for F° or C° operation through the GEN X App.

While in the Thermostat Configuration Menu, Select **Temperature F/C**

To view the current temperature operation (*View only function*)

Tap to go back to the menu, to return to the home screen tap

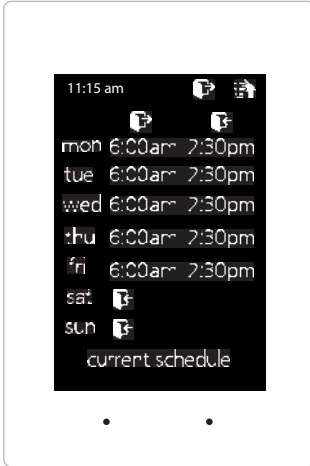

CURRENT SCHEDULE



View the current thermostat schedule, given by the Gen X system

While in the Thermostat Configuration Menu, Select **Current Schedule**

This allows you to view the schedule for that zone. Changes to the schedule are done through the GEN X App. *(View only function)*

Tap  to go back to the menu, to return to the home screen tap 

TIME & DATE

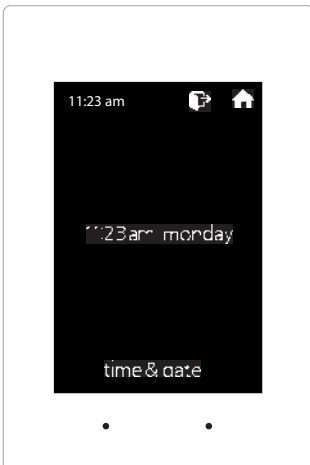

View the current time and date, given by the Gen X system.

While in the Thermostat Configuration Menu, Select **Time & Date**

To view the current time and date on the Gen X system *(View only function)*

Tap  to go back to the menu, to return to the home screen tap 

THERMOSTAT ADVANCED MENU

To access the Thermostat Advanced Menu: Tap on the degree symbol next to the room temp . The degree symbol will change color from white to green and then tap .

The **THERMOSTAT ADVANCED MENU** allows you to:

Set ID

Select Aux Heat

Select damper type

Temp Source

Select Menu Type

Diagnostic

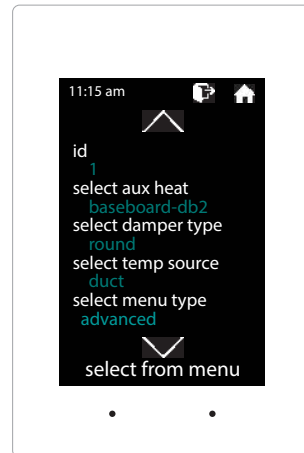
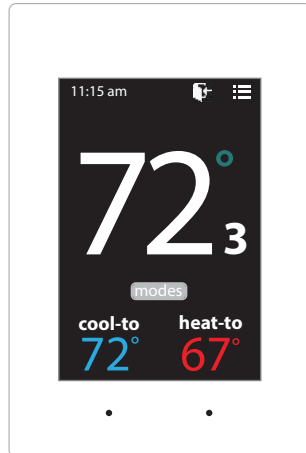

STAT ID

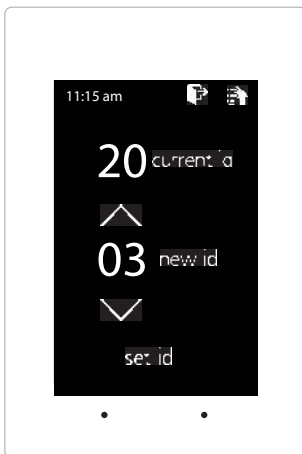

Every thermostat in the system needs a unique ID. They must be ID'ed in numerical order the way the communication wire is daisy chained. No duplicate addresses.

While in the Thermostat Advanced Menu, Select **SET ID**

Use the and arrows to set the new ID ranging from 1-20

Tap to save changes, to return to the home screen tap

Note: (All thermostats receive a unique ID 01 to 20, maximum of 20 zones per GEN X and GEN X RM controllers.)

SELECT AUX HEAT

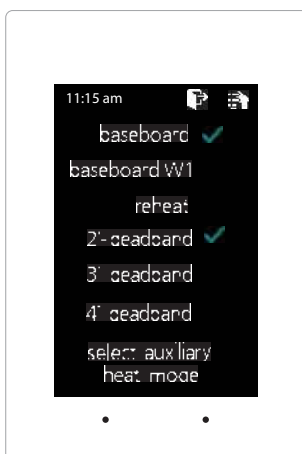

The zone thermostat provides the following Auxiliary Heat options; Baseboard, Baseboard W1 and Reheat with configurable dead band of 2°, 3°, or 4°.

While in the Thermostat Advanced Menu, Select **Aux Heat**

Select the desired auxiliary heat operation and dead band

Tap to save changes, to return to the home screen tap

Note: Reheat has a fixed 2° dead band.

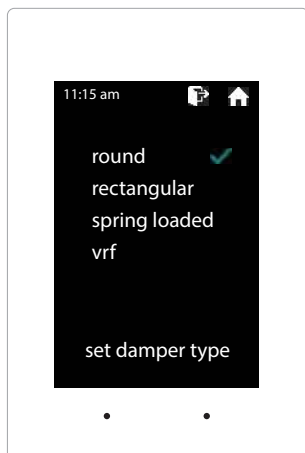

SELECT DAMPER TYPE



The EzTouchX needs to be configured for the type of damper that it is wired to. There are 4 options, round, rectangular, spring loaded or vrf.

While in the Thermostat Advanced Menu, **Select Damper Type**

Select round, rectangular, spring loaded or vrf damper operation

Tap  to exit diagnostic screen, to return to the home screen tap 



TEMP SOURCE



Temp source allows the thermostat to display the outside air temperature, supply air duct or relative humidity at the top on the home screen. A LAT sensor needs to be installed to report this reading. It will read 00 if no sensor is installed.

While in the Thermostat Advanced Menu, Select **Temp Source**

Select outside, duct, humidity or no display to display or not display the duct temperature

Tap  to save changes, to return to the home screen tap 

SELECT MENU TYPE

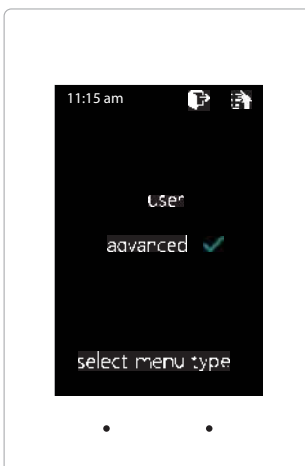



Menu type will allow you to see the advanced menu options under the user menu when advanced is selected.

While in the Thermostat Advanced Menu, Select **Menu Type**

Select **user** to hide the advanced options

Select **advanced** to show the advanced options under the user menu

Tap  to save changes, to return to the home screen tap 

DIAGNOSTIC

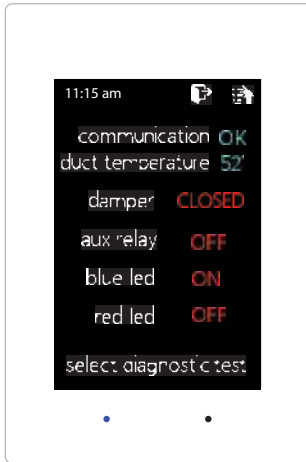

The EzTouchX Diagnostic screen will allow you to confirm communication with the GEN X controller and allow you to confirm damper, aux relay, and LED operation.



While in the Thermostat Advanced Menu, Select **Diagnostic**

Tap **damper** to confirm closed/open operation

Tap **aux relay** to confirm it energizes and de-energizes

Tap **blue led** to confirm the blue led illuminates

Tap **red led** to confirm the red led illuminates

Tap  to exit diagnostic screen, to return to the home screen tap 

AUXILIARY HEAT/REHEAT

The zone thermostat provides the following Auxiliary Heat options; Baseboard, Baseboard W1 and Reheat (see figure on the following page for more details) with configurable dead band of 2°, 3°, or 4°. **Note: Reheat has a fixed 2° dead band.**

Baseboard: the thermostat’s auxiliary output will energize when the room temperature drops 2° - 4° below the heat set point. Auxiliary heat operations will remain energized until the heat call is satisfied.

Baseboard W1: the auxiliary output will energize before the unit heater at 1° below heat set point. When the room temperature drops 2° - 4° below set point the thermostat will send a heat call to the unit heater. Auxiliary heat operations will remain energized until the heat call is satisfied.

Reheat: when the zone temperature drops 2° below the heat set point the damper will modulate to approximately 40% providing air flow over the electric heat strips, the AUX terminal will energize, and strip heat will provide reheat. **Note: When using in duct electric strip heater, an airflow proving switch is required for safe operation.**

Configuration of Auxiliary Heat/Reheat is accomplished by selecting “SELECT AUX HEAT” function in the Advanced Menu. To access the Advanced Menu tap the degree symbol of the room temperature (the degree symbol should change color to green) then tap the in the upper right corner of the thermostat, see Fig 1. Tap “Select Aux Heat”, see Fig 2. Select the desired Auxiliary Heat/Reheat and dead band (2°, 3°, or 4°) see Fig 3. Tap on to save desired settings. To return to the home screen tap

Home Screen

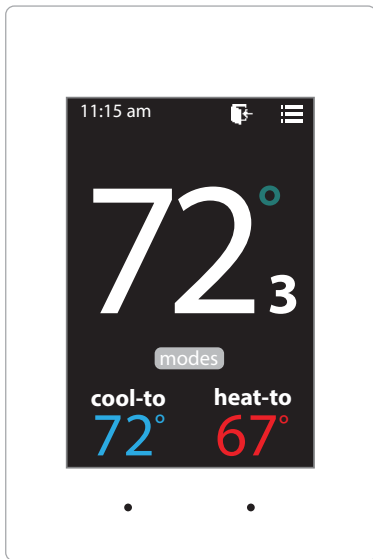

Fig 1

Advanced Menu

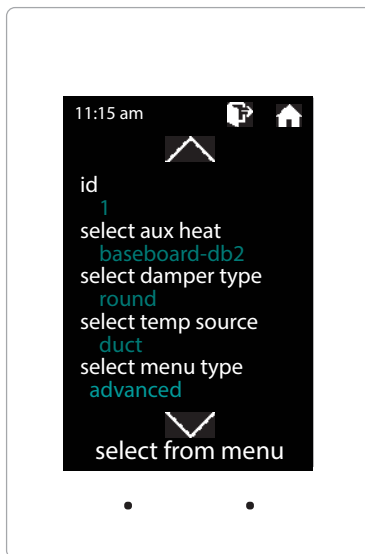

Fig 2

Select Aux Heat Menu

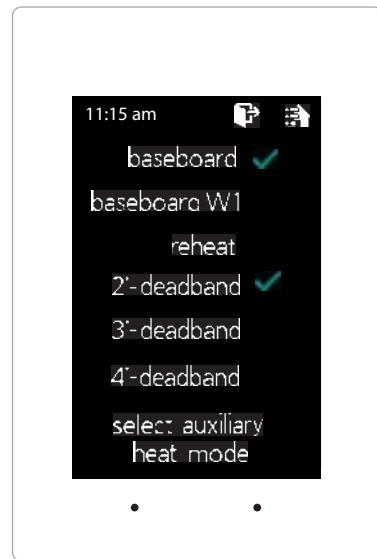
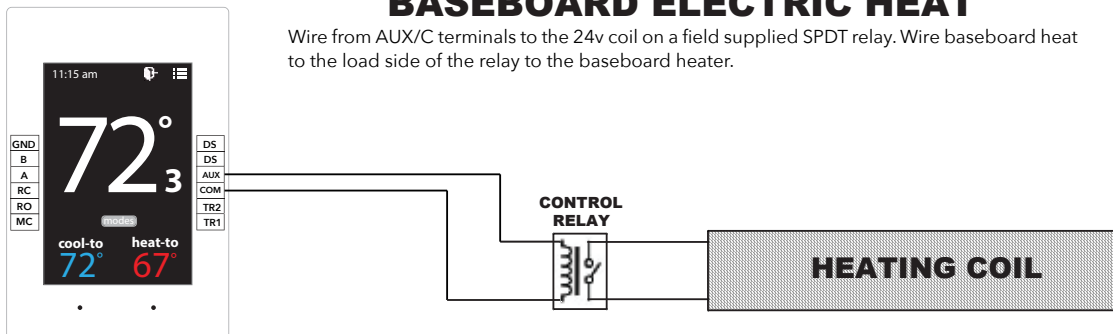

Fig 3

BASEBOARD ELECTRIC HEAT

Wire from AUX/C terminals to the 24v coil on a field supplied SPDT relay. Wire baseboard heat to the load side of the relay to the baseboard heater.



VAV DUCT REHEAT

Wire one AUX terminal to the air proving switch from the air proving switch complete wiring to the terminal on the 24v coil relay. Wire the C terminal to the 24v coil on the relay. Isolate control power to power baseboard heater.

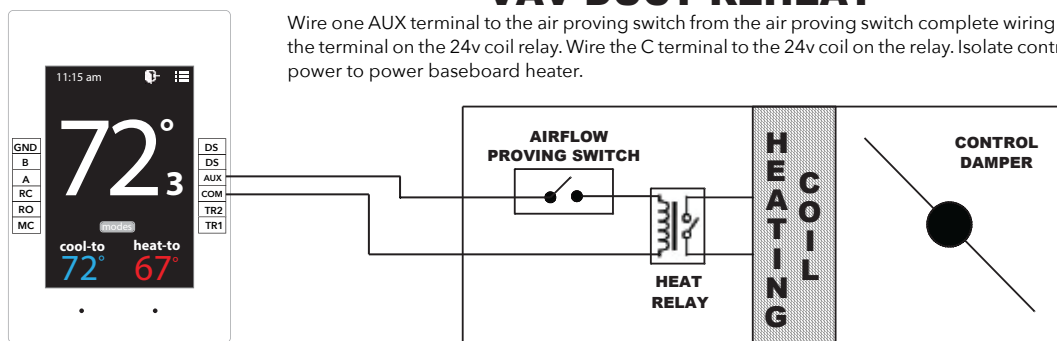

DUCT FAN REHEAT

Wire from the AUX/C to the 24v coil on a field supplied SPDT relay. Wire from one contact terminal to the 24v coil of the fan relay and to the air proving switch then wire the leaving side of the air proving switch to the 24v coil relay on the electric stripheater. Now wire the other contact to the transformer. Wire the other transformer leg to the fan and electric strip heater 24v coil terminals to complete the circuit. Isolated control power should be provided to power the fan and electric strip heater.

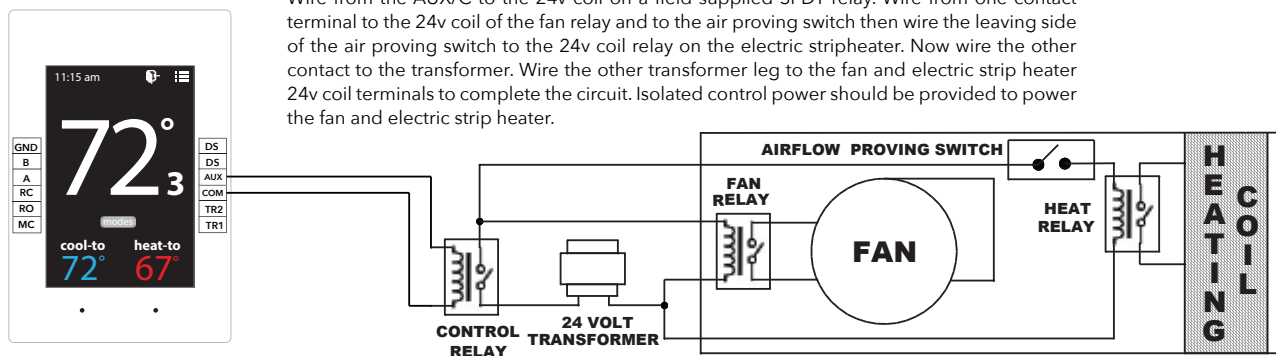

BASEBOARD HYDRONIC HEAT

Wire from AUX/C to 24v coil on a SPDT relay then wire from one contact terminal to the transformer and from the other transformer leg to the valve. On the other relay contact terminal wire to the valve to complete the circuit. Isolated control power should be provided to power the valve.

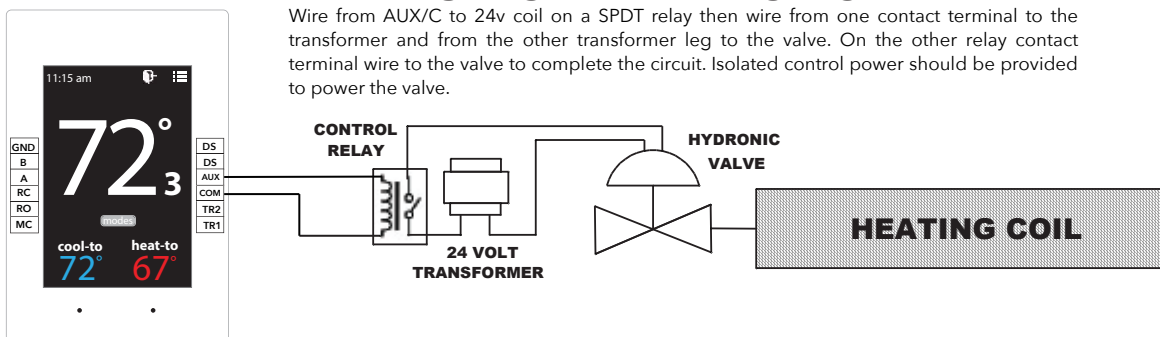

The GEN X can be configured to connect directly wirelessly between a mobile device for the purpose of communication and configuration. A connection between mobile devices is done with a static IP address. The following steps below outline this procedure.

Wireless connection for **Android** devices

1. Ensure that an Ethernet cable is NOT plugged into the GEN X (when a cable is plugged in the WiFi capability is automatically disabled).
2. Download the GEN X App from the Google Play store and install it on your mobile device.
3. On your mobile device open your Wi-Fi settings and scan for networks.
4. If the GEN X is powered on and within range **"GENX"** should appear in the list of the networks available to connect to.

5. Tap on **"GENX"** in the list of networks, your mobile device will attempt to connect to the GEN X and a popup list should appear. On the popup list select **"Show advanced options"**. If the popup list does not appear press and hold **"GENX"** until a popup list does appear, then tap **"Modify network"** and then select **"Show advanced options"**.



6. Under **"IP settings"** change **"DHCP"** to **"Static"**, under the **IP address** field type in 10.10.10.10, under the **Gateway** field type in 10.10.10.1 under the Subnet field (if present) type in 255.255.255.0 and then save the settings or tap **"Connect"**.

7. The word **"Connected"** should appear under **"GENX"** in the network list of your mobile device.
8. Open the GEN X mobile app, tap **"Yes"** for local access, tap **"SCAN LAN FOR GEN X"** and once the scan is complete select the GEN X from the drop down list at the top of the app.
9. Your mobile device is now connected to the GEN X via wireless connection. Configuration changes can now be made to the GEN X. If the GEN X is to be connected to an existing wireless network please call Zonex tech support to help with this set up. **Please note that the GEN X Wi-Fi range is approx 50 feet.**

Wireless connection for **Apple** devices

1. Ensure that an Ethernet cable is NOT plugged into the GEN X (when a cable is plugged in the WiFi capability is automatically disabled).
2. Download the GEN X App from the Apple App Store and install it on your mobile device.
3. On your mobile device tap on **Settings** and then tap on **Wi-Fi**. Ensure **Wi-Fi** is turned on.

4. If the GEN X is powered on and within range "**GENX**" should appear under **CHOOSE A NETWORK**. Tap on **GENX** once, **GENX** will then be automatically moved under **Wi-Fi**, tap **GENX** one more time.

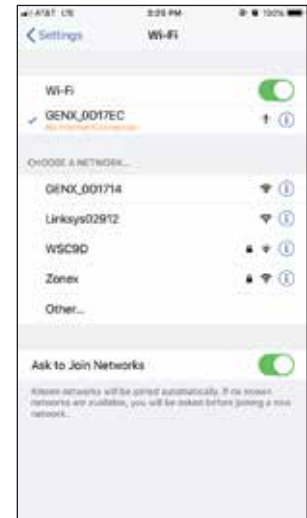

5. Under **IPV4 ADDRESS** tap **Configure IP**. On the next menu tap **Manual**. A menu will appear just below labeled **MANUAL IP**.
6. In the **IP address** field type in 10.10.10.10, in the **Subnet Mask** field type in 255.255.255.0 and in the **Router** field type in 10.10.10.1, and then tap **Save**.

7. Once connected the mobile device should have a check mark next to **GENX** indicating a connection.
8. Open the GEN X mobile app for local access, tap "**SKIP ACCOUNT LOGIN -- LOCAL CONNECTION ONLY**" and once the scan is complete select the GEN X from the drop down list at the top of the app.
9. Your mobile device is now connected to the GEN X via wireless connection. Configuration changes can now be made to the GEN X. If the GEN X is to be connected to an existing wireless network please call Zonex tech support to help with this set up. **Please note that the GEN X Wi-Fi range is less the 50 feet.**

An account needs to be created to access the GEN X system over the internet. Follow the steps below on how to create an account.

Open the Zonex mobile app and go to the log in screen.

Select - **CREATE NEW ACCOUNT**



Enter your information to sign up

USERNAME (case sensitive)

PASSWORD (case sensitive)

GIVEN NAME

EMAIL ADDRESS

PHONE NUMBER

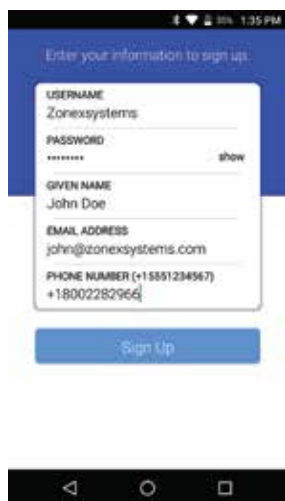

A confirmation code will be emailed to confirm the new account creation

ENTER THE CONFIRMATION CODE AND CONFIRM

NOTE: If you do not receive the confirmation code email, check the spam folder.

Once this step is completed you will need to contact Zonex tech support at 800-228-2966 to confirm and complete the account set up.

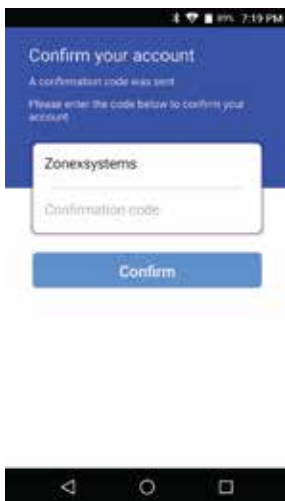

The mobile App communicates with the GEN X controller, via the Wi-Fi network and initiates control decisions for the system. Through the GEN X mobile app you can coordinate global or individual schedules for the system, lock thermostats individually and provide a user interface to make adjustments and establish master temperature settings individually or globally for the system. This user interface provides diagnostic functions to streamline system troubleshooting along with air balance shortcuts, password protection and many additional functions.

You will find outlined below the 25 unique functions that the GEN X offers:

System Configuration Menus

System feature changes are configured through the GEN X Mobile App for all zone stats and the GEN X System controller, along with additional RTU or Split systems controlled by their RM board.

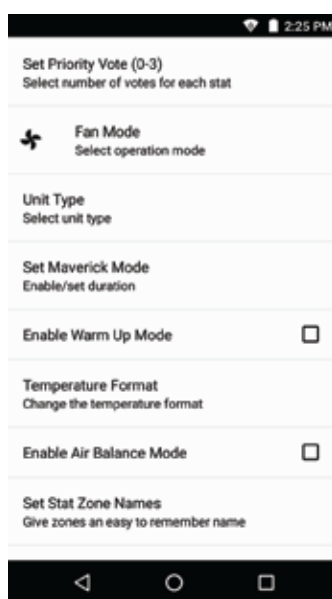
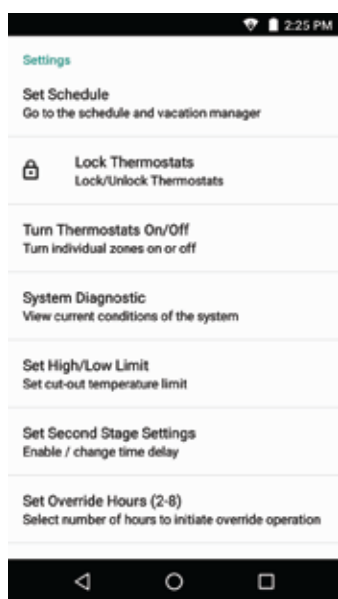

MENU FEATURES:

- | | |
|--|--|
| 01 SET SCHEDULE / VACATION SCHEDULE | 14 ENABLE AIR BALANCE MODE |
| 02 LOCK | 15 SET STAT ZONE NAMES |
| 03 TURN THERMOSTATS ON/OFF | 16 CHANGE GEN X / RM UNIT NAME |
| 04 SYSTEM DIAGNOSTIC | 17 CONFIGURE NUMBER OF THERMOSTATS |
| 05 SET HIGH / LOW LIMITS | 18 CONFIGURE NUMBER OF RM'S ATTACHED TO SYSTEM |
| 06 SET SECOND STAGE DELAY TIME | 19 ASSIGN RM ID |
| 07 SET OVERRIDE HOURS | 20 CONFIGURE NUMBER OF RLY-X ATTACHED TO SYSTEM |
| 08 SET PRIORITY MODE | 21 ASSIGN RLY-X ID |
| 09 FAN MODE | 22 SEE ZONE OVERVIEW |
| 10 UNIT TYPE | 23 CHANGE ALARM SETTINGS |
| 11 SET MAVRICK MODE | 24 CHANGE ADR SETTINGS |
| 12 ENABLE WARM UP MODE | |
| 13 TEMPERATURE FORMAT F° / C° | |

01 SCHEDULE / VACATION

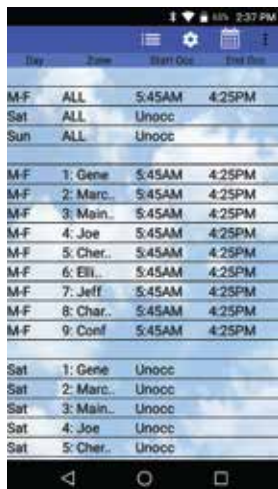

Tap **Set Schedule** or Tap on 
 Tap **Change Daily Schedule** format
 Choose your format **5-1-1**, **24/7** or **Daily Schedule**
 Tap **Set Daily Schedule**
 Tap **M-F ALL**
 Choose **Set Occupied Time** or **Set Unoccupied**
 Set **Occupied Start Time**, Press **Ok**
 Set **Occupied End Time**, Press **Ok**



Tap **Sat or Sun ALL**
 Choose **Set Occupied Time** or **Set Unoccupied**
 Set **Occupied Start Time**, Press **Ok**
 Set **Occupied End Time**, Press **Ok**

SETTING 2ND DAILY SCHEDULE:

Tap **Set 2nd Daily Schedule**
 Tap **M-F ALL**
 Choose **Set Occupied Time** or **Set Unoccupied**
 Set **Occupied Start Time**, Press **Ok**
 Set **Occupied End Time**, Press **Ok**

Tap **Sat or Sun ALL**
 Choose **Set Occupied Time** or **Set Unoccupied**
 Set **Occupied Start Time**, Press **Ok**
 Set **Occupied End Time**, Press **Ok**

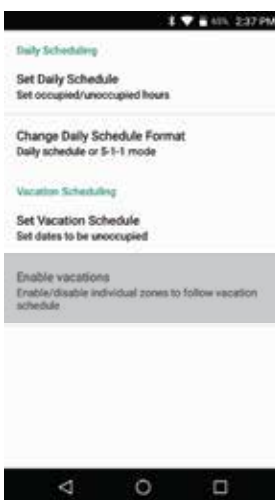

VACATION SCHEDULE

Tap **Set Schedule**
 Choose **Set Vacation Schedule**
Press Add Vacation
 Tap a **Date** on the **Calendar** to **Start Vacation**
 and another to **End Vacation**, Press **Ok**
 Tap **Enable Vacations**
 Choose **Individual zones** or **All Zones** to follow vacation
 schedule

TO NAME A VACATION SCHEDULE

Tap the **Vacation schedule** that you want to name
 Tap **Change name** and enter the new name, Press **Ok**

TO DELETE OR EDIT A VACATION SCHEDULE

Tap the current **Vacation Schedule** you want to
Delete or **Edit**
 Tap **Delete** or **Edit**

02 LOCK THERMOSTATS



Thermostats can be locked independently or globally through your Mobile device, when a thermostat is locked the end user will have limited operation ($\pm 2^\circ$) or no variance (0°) of the thermostat from heating or cooling set points.

Tap **Lock Thermostats**

Select **Zone Stat** or **All Zones** and choose **$\pm 2^\circ$** or **0°** lock.

- Confirms zone thermostat is locked.

03 TURN THERMOSTAT ON / OFF



The thermostat On and Off function will allow you to turn individual thermostats On and Off.

Tap **Turn Thermostat On/Off**

Select the zone or zones you want to turn **Off** or **On**

- To turn OFF the thermostat uncheck the box.

Note: Off is displayed on the thermostat.

04 SYSTEM DIAGNOSTIC



Allow the user to review the current conditions for the GEN X systems. Number of Active thermostats in the system, how many are communicating, thermostats that are off, Unit status, Leaving Air Temperature, Return Air Temperature and Outside Air Temperature all from your mobile device.

Tap **System Diagnostic** or access from **Extended feature menu**.

Scroll **Down** to view **Active Zones** and unit conditions.

Tapping on a zone thermostat, (under **Thermostat Status**) will allow you to adjust the zone set point.

Troubleshooting Note: System Diagnostic is a great tool to use to confirm communications with thermostats and detect communication errors or wiring errors in the system.

05 HIGH/LOW LIMIT



For system protection the GEN X has High and Low limit set point built into the Mobile Device configurations. Factory defaults for Gas/Electric operations are High Limit of 145° F and Low Limit of 45° F, for Heat Pump operations factory defaults are High Limit 115° F and Low Limit of 45° F. These can be field configured as required.

Tap **Set High/Low Limit**

Tap **Set High Limit, Confirm or Change High Limit (Range 100° F - 160° F)**

Select **OK** when done

Tap **Set High/Low Limit**

Tap **Set Low Limit, Confirm or Change Low Limit (Range 40° F - 50° F)**

Tap **OK** when done

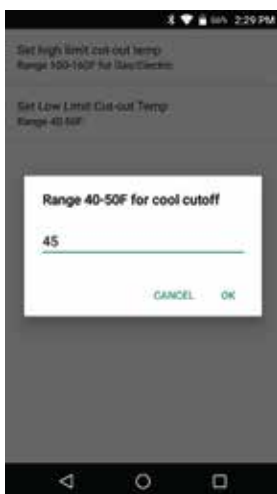

06 SECOND STAGE DELAY

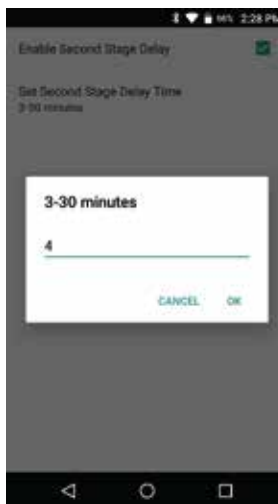
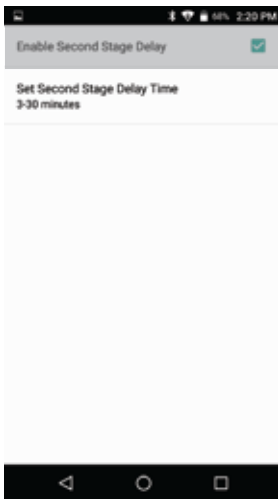

The GEN X controller can be configured for TIME/TEMP or TIME ONLY second stage operation. TIME/TEMP strategy uses both run time and leaving air temperature to determine when to initiate second stage heat or cool. TIME ONLY strategy uses run time to stage second stage heat/cool operation. Factory default is TIME/TEMP, the run time is preset to 3 minutes; however this can be reset up to 30 minutes.

Time / Temp Configuration

Tap **Set Second Stage Delay Settings**

Enable Second Stage Delay

Tap **Set Second Stage Delay Time**

Choose **3-30 minutes**, Tap **OK**

Time only Configuration

Tap **Set Second Stage Delay Settings**

Tap **Set Second Stage Delay Time**

Choose **3-30 minutes**, Tap **OK**

Disable Second Stage Delay by tapping the checked box.

07 OVERRIDE HOURS



Select the number of hours to initiate override operation. Select 2-8 hours in the setback mode. Tap  once on the thermostat to initiate override operation. The “override” can be tapped again to terminate override operation.

Tap **Set Override Hours**

Choose **2-8 hours for override operation**, Tap **OK**

This is a global function, all thermostats on this unit will operate with the override time selected.

08 PRIORITY VOTE



This function allows system configuration to determine the weight of the vote sent from each thermostat. Factory default is set to 1 vote per thermostat. When needed, a thermostat can be configured for higher weight by adding up to 2 additional votes for a total of 3 votes maximum granting higher priority to that zone. Additionally, if there is a desire for a thermostat to not place a call for heating or cooling, a null vote may be configured by using a value of 0 in the priority vote menu, when null vote is selected the thermostat is a slave to the GEN X system.

- Tap **Set Priority Vote**
- Tap **Zone Stat of Choice**
- Enter **0-3 Votes for Zone Stat, Press OK**

09 FAN MODE



Fan operation for either Fan ON or AUTO. When system is configured for ON operation, the Fan will run during Occupied Schedule and will revert to Auto operations during unoccupied schedule. When system is configured for Auto operation, Fan will only run when there is a call for heating or cooling,

- Tap **Operation Mode (ON or AUTO)**
- Tap **Fan Mode**
- Choose **AUTO or ON**

10 UNIT TYPE



The Gen X is designed as a universal GAS/ELECTRIC/HEAT PUMP Controller. Factory default is set for GAS operations, and may require field configuration when applying this product to Electric or Heat Pump applications.

- Tap **Unit Type**
- Choose **Unit Type (Gas, Heat Pump O/B, Electric)**

11 SET MAVERICK

Maverick operations allow the system to recognize an outlier call in the system. When most zones in a system are calling for heat and 1 zone is calling for cooling, the system will initiate a MAVERICK CALL protocol by starting a time clock. Logic in the controller will provide a time period for first calls to satisfy, and then run a purge cycle and energize the maverick call. Maverick call will remain on until zone satisfied, then run purge and return to majority operations.

Tap **Set Maverick Mode**

Enable Maverick Mode (Enabled when box is checked)

Choose **3-30 minutes**, Press **OK**

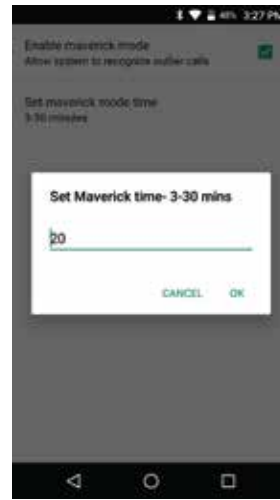

12 ENABLE WARM UP MODE

In cold climates a MORNING WARM UP sequence will assist in preheating the building prior to occupancy. The GEN X system provides a strategy for morning warm up based on a sophisticated algorithm built into the system controller. When enabled, the system will switch from Unoccupied to Occupied two hours prior to system start time and run heating for 20 minutes to evaluate time needed to raise building temperature, after 20 minutes system will return to Unoccupied mode. Using the information gathered from the 20 minute warm up evaluation, thermostats will reset individual occupied start times to provide morning warm up for each zone in the building.

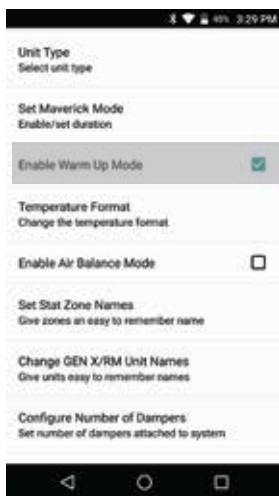

Enable Warm up Mode (Enabled when box is checked)

13 TEMPERATURE FORMAT

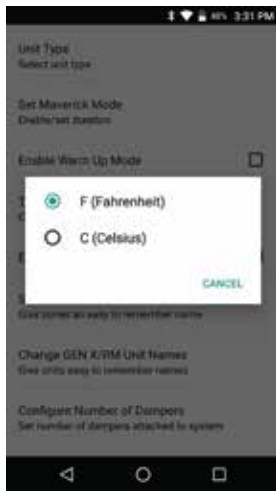

GEN X may be configured for F° or C° operations.

Tap **Temperature Format**
Choose **F° or C°**

14 AIR BALANCE MODE

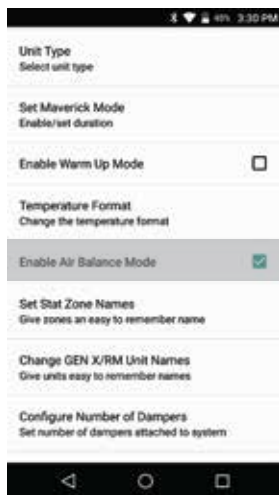

During the start up and commissioning of the system, an air balance may be required. Enable the air balance mode to Start, this will drive all dampers to the open position, energize the fan and lock out compressor or heat function. When air balance is complete, Tap the Enable Air Balance mode to STOP air balance mode and place the system back to normal operation.

Enable Air Balance Mode (Enabled when box is checked)

15 SET STAT ZONE NAMES



This allows you to give each zone a specific name.

Tap **Set Stat Zone Names**
Tap **Zone stat that you want to name**
Enter name of zone, Press OK
Repeat for all additional zones that need to be named

16 CHANGE GEN X / RM UNIT NAMES

This allows you to give the GEN X and GEN X RM's a specific name.



Tap **Change GEN X / RM Unit Names**

Tap **Unit you want to name**

Enter name for that unit, Press OK

Repeat for all additional units that need to be named

17 CONFIGURE NUMBER OF THERMOSTATS

Installer must set the number of thermostats in the system. This reduces the need for the GEN X controller to poll and review each zone's needs. Installer can set the number of thermostats from 1-20.



Tap **Number of Thermostats**

Enter how many zones in this system 1-20, Press OK

18 CONFIGURE NUMBER OF RM'S ATTACHED TO SYSTEM

Configuring the number of RM's attached to system allows the GEN X to know how many RM's it will be communicating with. It also needs to know how many RM's will be in the system to sync properly.



Tap **Configure Number of RM's Attached to System** and enter the number of RM's attached to the system.

Note: Each RM can support up to 20 thermostats or zones

19 ASSIGN RM ID



Each GEN X RM receives an ID number ranging from 1-20. This allows the GEN X mobile app the ability to communicate with multiple RM's through the GEN X controller. The RM's need to be ID'd and synced in the order of the daisy chain.

Tap **Assign RM ID**

Enter the ID of the first RM in the system, press OK

When the blue light on the RM you wish to sync starts flashing rapidly, hold the sync button on the RM controller that you wish to sync for 15 seconds. When the light stops flashing the sync is complete.

20 CONFIGURE NUMBER OF RLYX ATTACHED TO SYSTEM

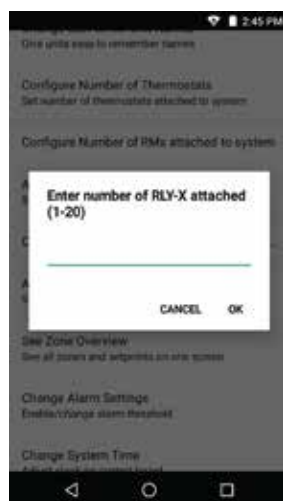

Configuring the number of RLYX allows the GEN X to know how many it will be controlling for the syncing process

Tap **Configure Number of RLYX's attached to system and enter the number of RLYX that are attached to the GEN X.**

Note: Each RLY-X can support up to 5 generic loads.

21 ASSIGN RLYX ID



Each RLYX receives an ID number ranging from 1-20. This allows the GEN X mobile app the ability to communicate with multiple RLYX's through the GEN X controller. The RLYX's need to be ID'd and synced in the order of the daisy chain.

Tap **Assign RLYX ID**

Enter the ID of the first RLYX in the system, press OK

When the blue light on the RLYX you wish to sync starts flashing rapidly, hold the sync button on the RLYX controller for 15 seconds when the light stops flashing the sync is complete.

22 SEE ZONE OVERVIEW

Zone	Temp	Occupied	Heating/cool	Heating/cool
1: Gene	72.3°	66/73	66/85	
2: Marcos	72.6°	66/74	60/95	
3: Main Off	72.9°	66/72	60/95	
4: Joe	70.7°	66/72	60/95	
5: Cheryl	73.0°	69/74	60/95	
6: Ellie	74.6°	67/74	60/95	
7: Jeff	72.2°	66/72	60/95	
8: Charlotte	72.7°	67/72	60/95	
9: Conf	73.0°	68/73	60/95	

Zone overview will let you review all the zones, current room temperatures, active cooling calls in blue, active heating calls in red along with Occupied and Unoccupied set points.

Select **Zone Overview** to see all zone set points and current room temperatures

23 ALARM SETTINGS

Once enabled this allows email/text notifications of faults in the system such as low battery, temperature out of range.

Enable zone out of range alarm

Enter time to wait before alarming (5-90 minutes)

CANCEL OK

1 2 3 -

4 5 6 +

7 8 9

0 .

Enable zone out of range alarm

Enter temperature threshold for alarming (3-10 degrees)

CANCEL OK

1 2 3 -

4 5 6 +

7 8 9

0 .

Select **Change Alarm Settings**

Enable zone out of range alarm

Select **Set time out of range for alarm (5-90 minutes)**

Enter the time to wait before alarming; Press Ok

Select **Set temperature out of range for alarm (3-9°)**

Enter temperature threshold for alarming; Press Ok

Select **Alarm Subscription Settings** to add/remove text and email alarm subscriptions.

Select **Sign up for alarm notifications** email or text and enter the email addresses or phone #'s of the individuals that want to receive the alarm notifications.

You will receive a Subscription Confirmation email, to activate the alarming you will need to confirm the subscription.

To Unsubscribe from Alarms, entire the email address or phone # in the Unsubscribe from alarms.

* For alarming to function, account set up is required.

24 CHANGE ADR SETTINGS



When the 3rd party device receives an ADR signal from the utility service provider its contacts close, the GEN X & RM's set back their thermostats 4° for both the heating & cooling modes and lock the thermostat set points so they cannot be adjusted at the thermostat during the ADR event. Once the ADR event has concluded the thermostats unlock and return to their original set points.

Tap **Change ADR Settings**

Select the zone or zones you want to enable

To enable the thermostat for ADR

The Extended Menu Options  will allow access to additional control systems tied to the GEN X controller or account, check the system diagnostic, view contractors information and log out or exit the app.

System Diagnostic - Gives an overview of the system you are currently connected to including number of Thermostats the system is configured for, Leaving, Return & Outside air temps, System Status (Heat, Cool or Vent operation), number of Heat and Cool calls and Thermostat Status.

Log Out of Account - Will log you out of your account and takes you back to the option screen for logging in to the system over the internet or accessing a system on the same local network that your mobile device is also connected to.

Change RM/GEN X (Same System) - Allows you to switch between a GEN X and RM's on the same system you are currently connected to. This option can be used for over the internet or local network connections.

Change RM/GEN X (Separate System) - Allows you to connect to any of the GEN X systems that are associated with your user account. This option is used for over the internet connections only.

Exit App - Closes the GEN X app.

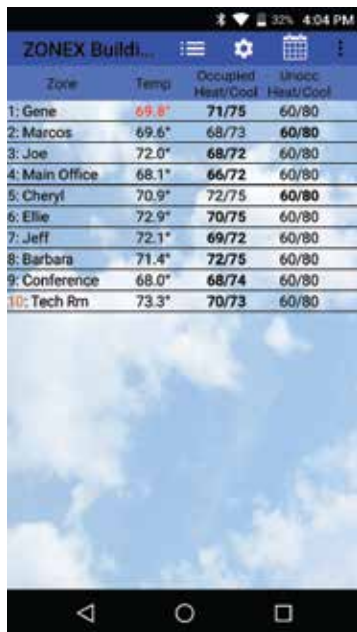

Zone	Temp	Occupied Heat/Cool	Unocc Heat/Cool
1: Gene	69.8°	71/75	60/80
2: Marcos	69.6°	68/73	60/80
3: Joe	72.0°	68/72	60/80
4: Main Office	68.1°	66/72	60/80
5: Cheryl	70.9°	72/75	60/80
6: Ellie	72.9°	70/75	60/80
7: Jeff	72.1°	69/72	60/80
8: Barbara	71.4°	72/75	60/80
9: Conference	68.0°	68/74	60/80
10: Tech Rm	73.3°	70/73	60/80



GEN X WEB-PORTAL LOGIN - END USER INTERFACE

The GEN X controller can be accessed from any web browser. Accessing the GEN X over the internet requires a user name and password that is set up through the Zonex mobile app and confirmed by Zonex tech support.

If you need help setting up an account call Zonex tech support at 800-228-2966.

To access the GEN X go to: www.genxcontrol.com

Enter the user name and password: Click Login

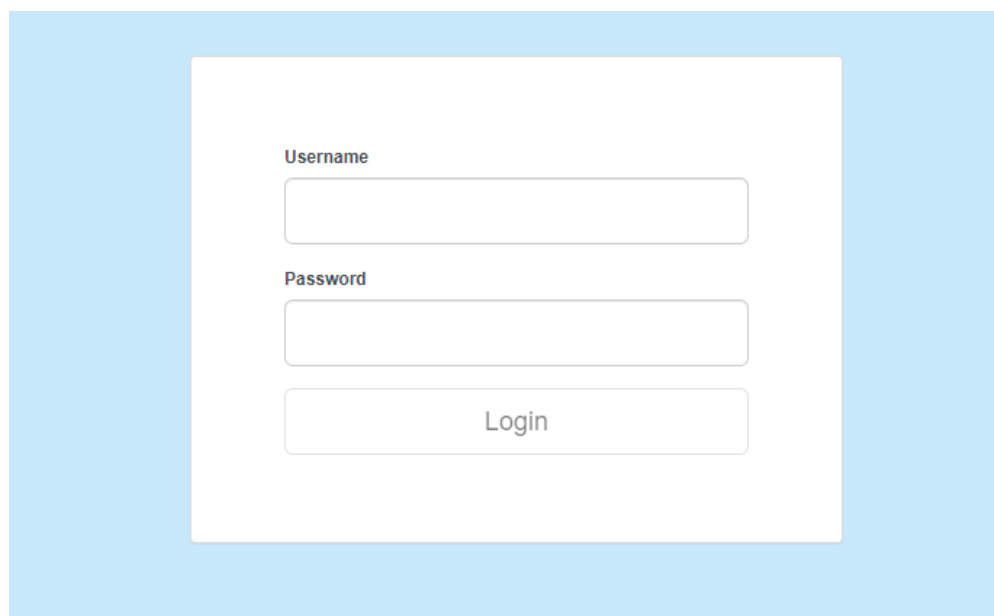

The image shows a login form with a light blue background. The form is centered and contains three input fields. The first field is labeled "Username" and is empty. The second field is labeled "Password" and is empty. Below the password field is a button labeled "Login".

END USER INTERFACE OVERVIEW

You can review and perform the following:

- Review all zones on a system by system basis
- Change occupied and unoccupied thermostat setpoints
- Lock/unlock thermostats
- Review the system status, leaving and return air temperatures
- Review priority votes on zone thermostats
- Review and change zone schedules and vacation days
- Review and change zone names
- Set temperature format

ZONE OVERVIEW

Once you have logged into the end user interface you will see all the zone thermostats associated with the GEN X controller.

To see other zoned roof top units or split systems. Click in the left hand column, a drop down will appear. Click on the RM controller that you wish to view.

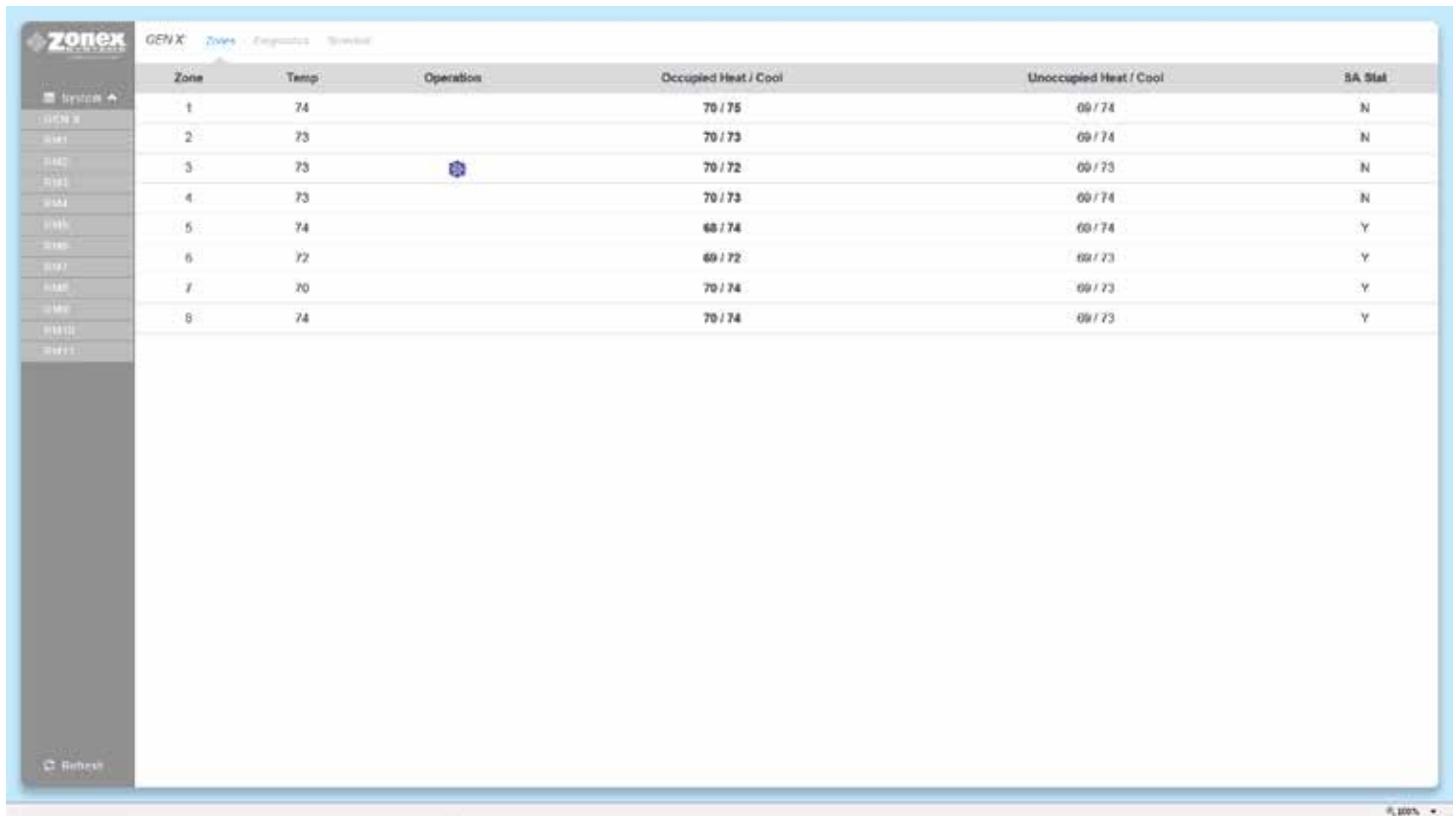

The screenshot shows the Zonex GEN X Zones page. The table displays the following data:

Zone	Temp	Operation	Occupied Heat / Cool	Unoccupied Heat / Cool	SA Stat
1	74		70 / 75	69 / 74	N
2	73		70 / 73	69 / 74	N
3	73		70 / 72	69 / 73	N
4	73		70 / 73	69 / 74	N
5	74		68 / 74	69 / 74	Y
6	72		69 / 72	69 / 73	Y
7	70		70 / 74	69 / 73	Y
8	74		70 / 74	69 / 73	Y

Note: If the web-portal doesn't seem to load right, delete the cash and cookies in the web browser and reload the web-portal.

CHANGING ZONE THERMOSTAT TEMPERATURES

To change temperatures on a zone thermostat. Click the zone you wish to change the temperature on.

To change either the Cool set point (Blue Dot) or Heat set point (Red Dot) slide the corresponding dot to the left to lower the temperature and to the right to raise the temperature. After making temperature changes click on the X in the upper right corner of the pop up box to exit this screen. Changes will be transmitted to thermostats remotely.

Both Occupied and Unoccupied set points can be changed at this screen.

Note: The system is designed to maintain a 2° dead band between the heating and cooling set points.

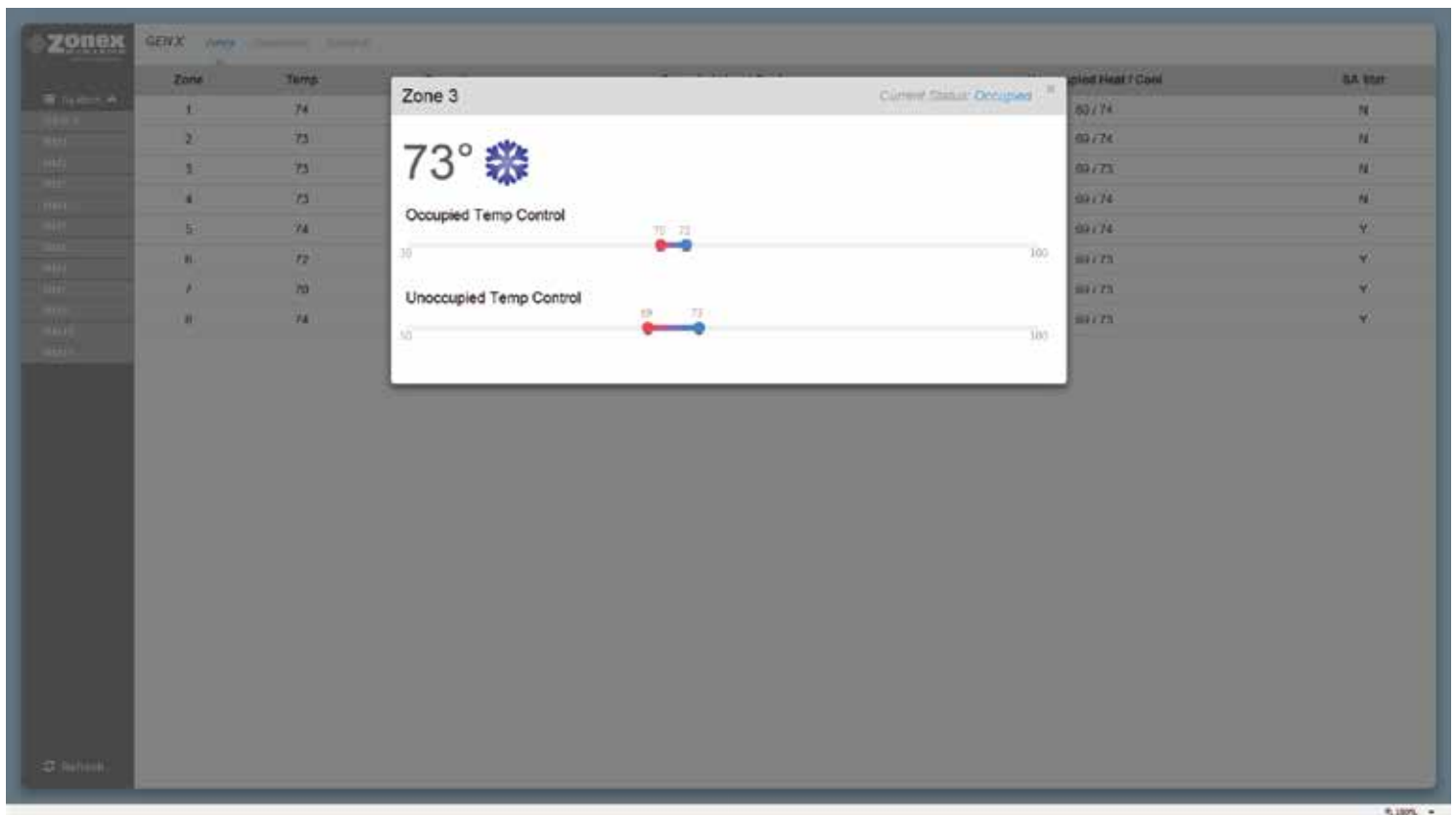

DIAGNOSTICS SCREEN

The diagnostic screen allows you to view the leaving, return, and outside air temperatures and the current status of the system.

Under the Priority Votes column you can view the number of votes assigned to a thermostat as well as the mode of operation the thermostat is calling for (Cool, Heat, or Off/No Call).

The buttons under the Locked/Unlocked column are used to change thermostats so they can be LOCKED with 0° variance, PARTIAL LOCK +/- 2° or UNLOCKED. If you wish to lock or unlock all zone thermostats click on Unlock All / Lock All in the bottom right corner below the last zone status.

The Status column indicates the current status of communication between the thermostat and GEN X controller.

If you have standalone thermostats (SATouchX) connected to the GEN X / GEN X RM controllers, the humidity, leaving and return air temperatures are displayed at the bottom of the diagnostic screen.

System Diagnostics

Leaving Air: 46° Return Air: 66° Outside Air: 64° Status:

Zone	Priority Votes	Locked/Unlocked	Status
1: Gene	1 - OFF	UNLOCKED	DAMPER & STAT OK
2: Marcos	1 - OFF	UNLOCKED	DAMPER & STAT OK
3: Joe	1 - OFF	UNLOCKED	DAMPER & STAT OK
4: Main Office	1 - COOL	PARTIAL LOCK	DAMPER & STAT OK
5: Cheryl	1 - OFF	PARTIAL LOCK	DAMPER & STAT OK
6: Elle	1 - OFF	UNLOCKED	DAMPER & STAT OK
7: Jeff	1 - OFF	UNLOCKED	DAMPER & STAT OK
8: Barbara	1 - OFF	UNLOCKED	DAMPER & STAT OK
9: Conference	1 - OFF	UNLOCKED	DAMPER & STAT OK
10: Tech Rm	1 - OFF	UNLOCKED	STAT OK

[Unlock All](#) [Lock All](#)

SA Stat	Humidity	Leaving Air	Return Air
10: Tech Rm	54%	65°	71°

SCHEDULE / VACATION SET UP

To set up schedules for the thermostats, click on Schedule.

To set the same schedule for all thermostats for all 7 days click on Occ Start under All Days in the All row. Select the time (hour, minute, and am/pm) you want the thermostats to start cooling / heating the zones. Next click on Occ End and enter the time you want the thermostats to stop cooling / heating the zones.

To set the schedule for all thermostats for weekdays ONLY (Monday - Friday) click on the field under the Weekdays column and the All row and follow the steps for changing time outlined above. Repeat this process for Saturday and Sunday fields. If a zone is to be unoccupied for the entire day select Unoccupied All Day.

Each thermostat can also be configured to follow its own unique schedule by clicking on the appropriate field in the row that corresponds to the thermostat you wish to setup.

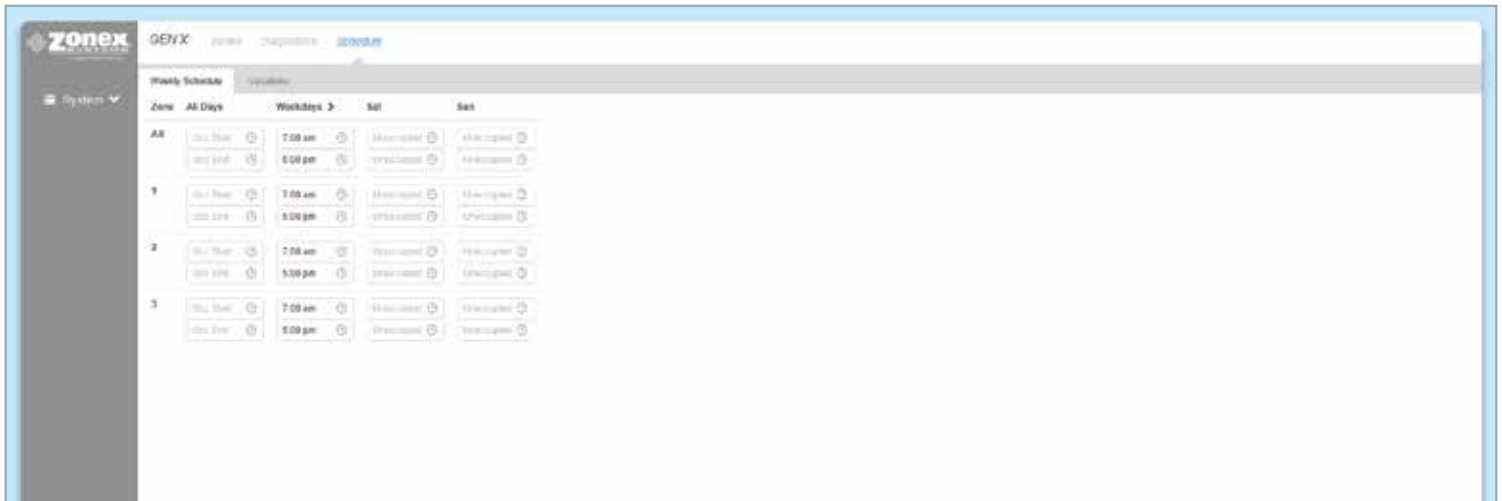

VACATION SET UP

To set a new vacation schedule or modify an existing one click on the Schedule menu and then click on the Vacations tab.

Under the Start Date ~ End Date column click on the Start date field and a calendar will pop up. The first date selected is the vacation start date and second date selected is the vacation end date. The system will go into unoccupied mode during these days and will follow the normal schedule thereafter.

To delete a vacation schedule simply click on the DELETE button next to the one you wish to delete.

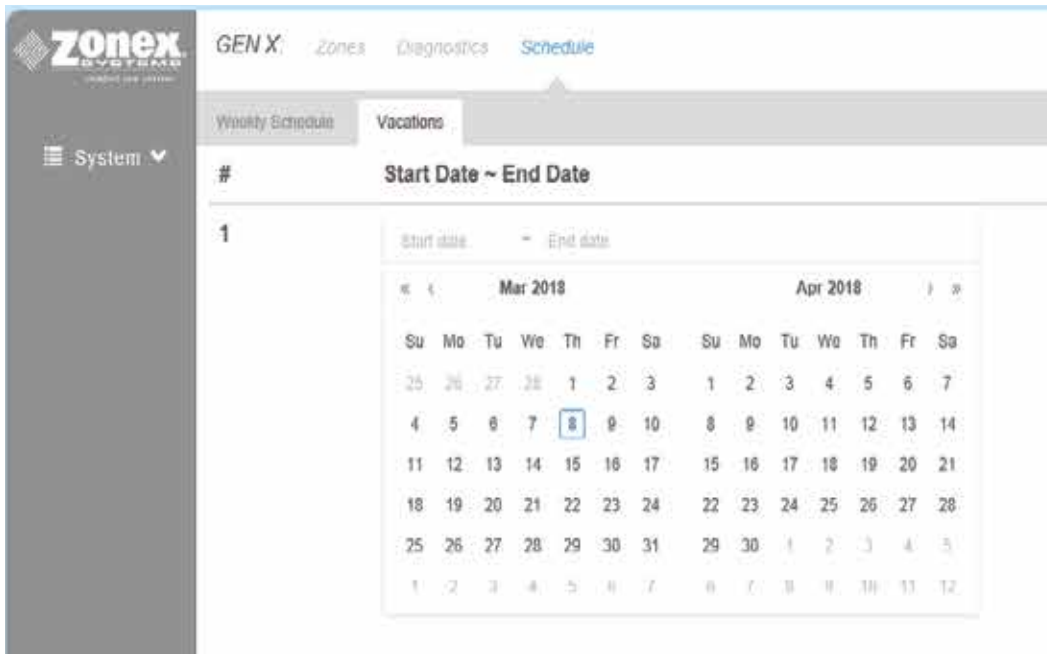
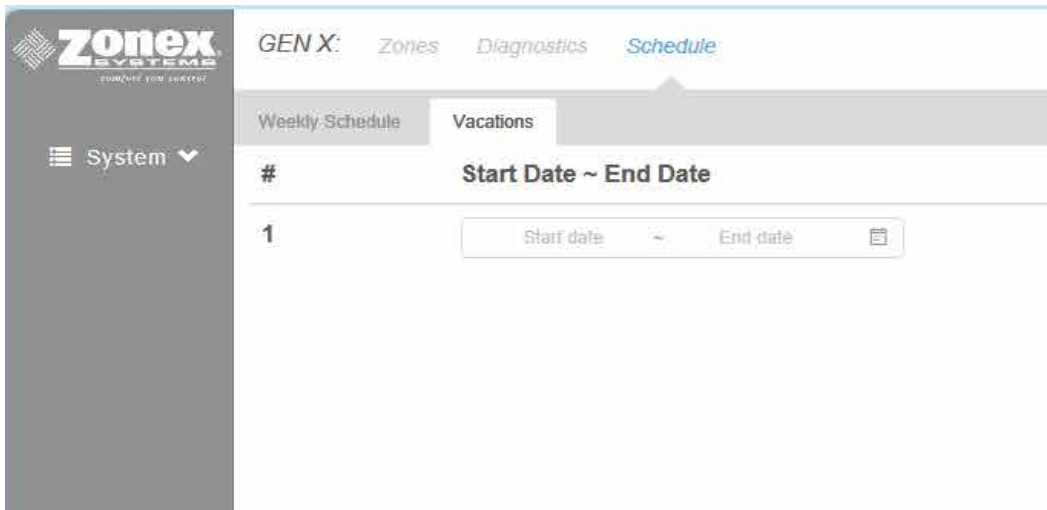

CHANGING TEMPERATURE FORMAT AND ZONE NAMES

The options under the Settings menu will allow changes to the temperature format, system name and zone names.

To change the temperature scale click on the button below Temp. Display Format and the switch will move to the left for Fahrenheit and to the right for Celsius.

To change either the System Name or Zone Names move the pointer over the name to be changed, click on Edit, change the field to the desired name and click on Save.

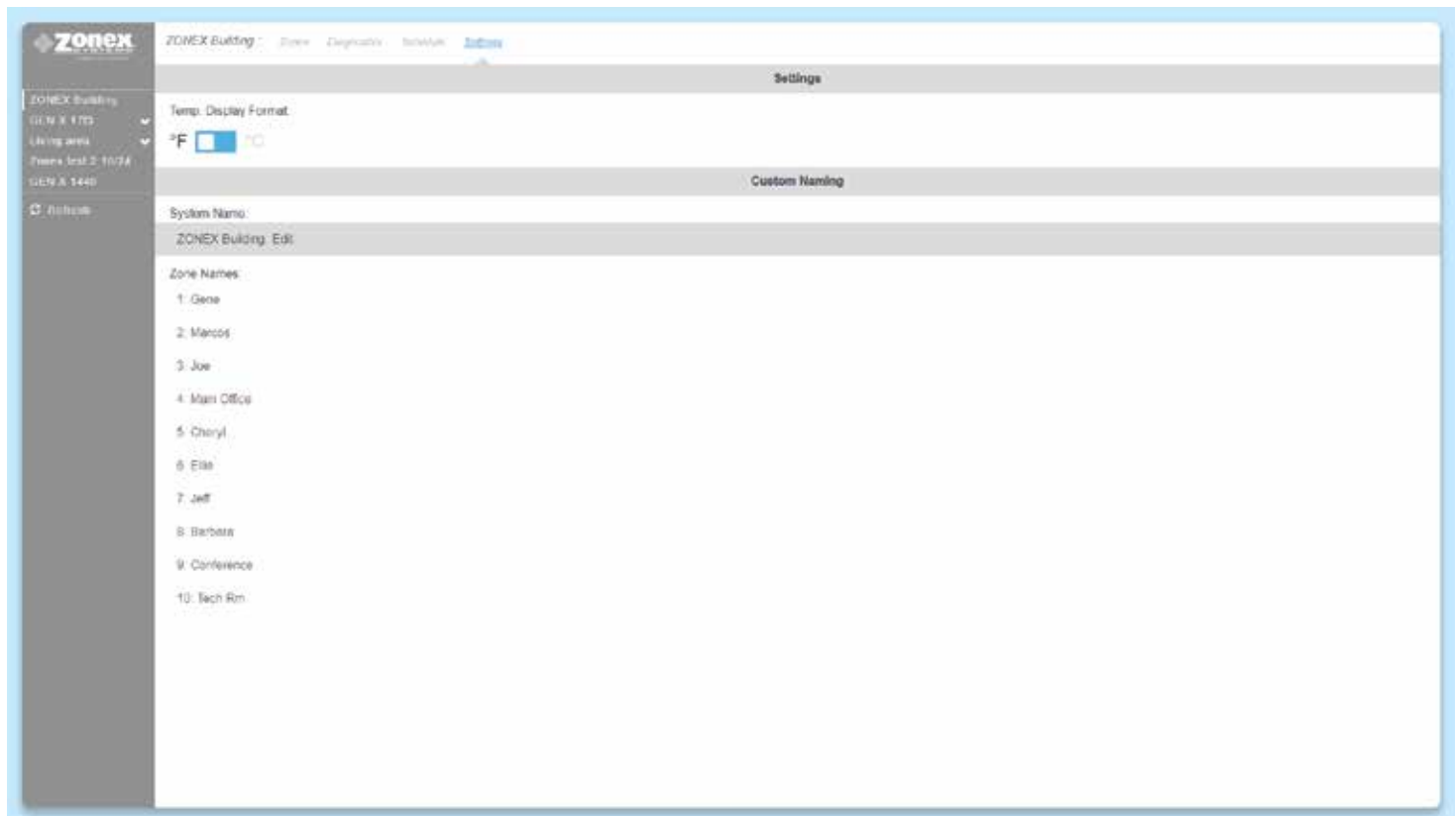



STAND ALONE UNIVERSAL THERMOSTAT

The SATouchX is a universal color touch screen programmable G/E or H/P thermostat, microprocessor based, auto changeover, stand alone thermostat used to control stand alone fan coil units with the GEN X system. The SATouchX is configured for Gas/Electric (2H, 2C) with selectable fan operation. The SATouchX reports the supply and return air temperatures and has a large, easy to read display.

The SATouchX is very easy to configure through the mobile App or by manually adjusting settings at the thermostat.

The SATouchX features an on board thermistor for precise temperature measurement. In the event of power loss, the Heat and Cool set points are stored in non-volatile memory, without the need for battery backup.

Space ambient temperature is continually displayed with large, easy-to-read numbers. SATouchX temperature display range is 47° - 95°F. Heat and Cool set points and operation modes are all indicated on the display.

Programmed set points can be manually adjusted at the thermostat or electronically locked through the mobile app to provide limited manual set point adjustment. During unoccupied hours, temporary operation can be overridden with a touch of a button.

Thermostat Operation

COOL - The thermostat will make a Y1 cool call when the space temperature rises 1° above set point. Y2 will energize when the space temperature rises 2° above the cool set point or whatever the 2nd stage temperature is set for. When the room temperature reaches set point Y1 and Y2 will de-energize. O or B energize for the reversing valve circuit, depending on configuration. The G circuit is energized for fan.

HEAT - The thermostat will make a W1 heat call when the space temperature is 1° below the heat set point. W2 will energize when the space temperature is 2° below the heat set point or whatever the 2nd stage temperature is set for. When the room temperature reaches set point W1 and W2 will de-energize.

Note: When the thermostat is configured for GAS operation the fan circuit is not energized in heat mode.

Note: When the thermostat is configured for ELECTRIC operation the fan circuit is energized in heat mode.

EMERGENCY HEAT - When Emergency Heat is selected in the configuration menu on the thermostat on a call for heat, there is an output signal on "W2" for backup heat and "G" for the fan. The compressor circuits Y1 and Y2 are locked out during heat calls, until the emergency heat function has been turned off in the configuration menu.

FAN MODE - Is factory set for "Auto", to configure the thermostat to run the fan constant "On". Go to Thermostat Advanced Menu, Select Fan Mode; Select the the desired fan operation "Auto" or "On".

INSTALLATION

Thermostat and Terminal base

1. Install the thermostat on an interior wall, away from drafts, supply air currents and direct sunlight or any heat generating source.
2. Remove the thermostat from its sub-base, by pulling the thermostat and sub-base apart.
3. Install the thermostat sub-base to the wall using the provided anchors and screws.

INSTALLATION INSTRUCTIONS

WIRING THE UNIT, SUPPLY AND RETURN AIR SENSORS TO THE SATouchX

Use 18/6 thermostat wire, wire from SATouchX to the RTU/split system. Make sure to match up the unit terminals to the SATouchX terminals R, Y1, Y2, W1/O/B, W2, G. Wire in the Supply and Return air sensors using 18/4 thermostat wire. Install the Supply (AT1) and Return Air (AT2) LAT sensors 18 to 24" downstream of the unit.

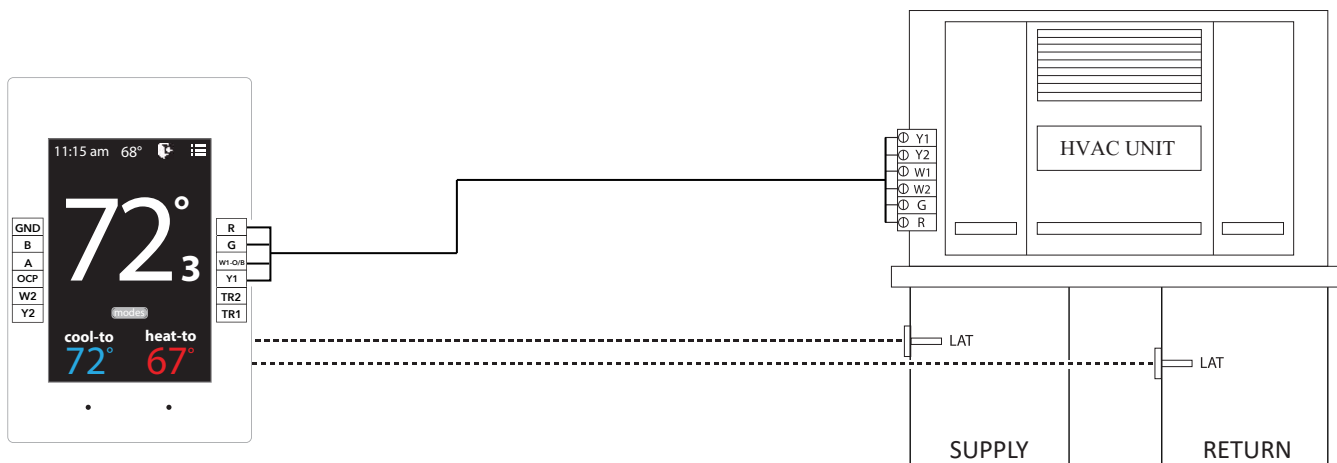

DAISY CHAIN THE COMMUNICATION WIRE

Using Zonex 2-TWP communication wire. Wire **IN** and **OUT** of A and B to and from SATouchX's in a daisy chain configuration.

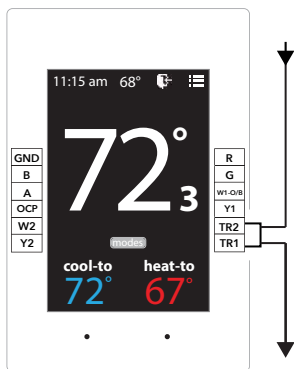
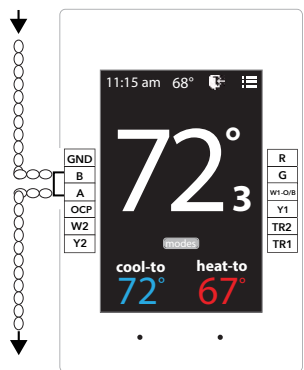

DAISY CHAIN 24V POWER FROM GEN X or GEN X RM

SATouchX is powered by the independent transformer connected to the GEN X. Using 18/2 wire for the 24vac power, daisy chain from TR1, TR2 **IN** and **OUT** to and from the SATouchX's.

Daisy Chain Multiple SATouchX's

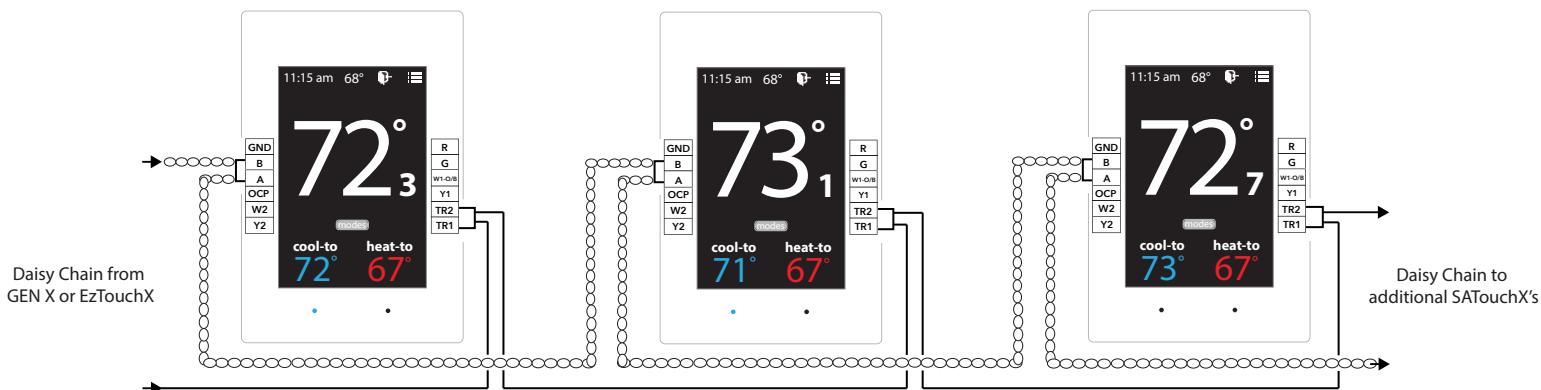

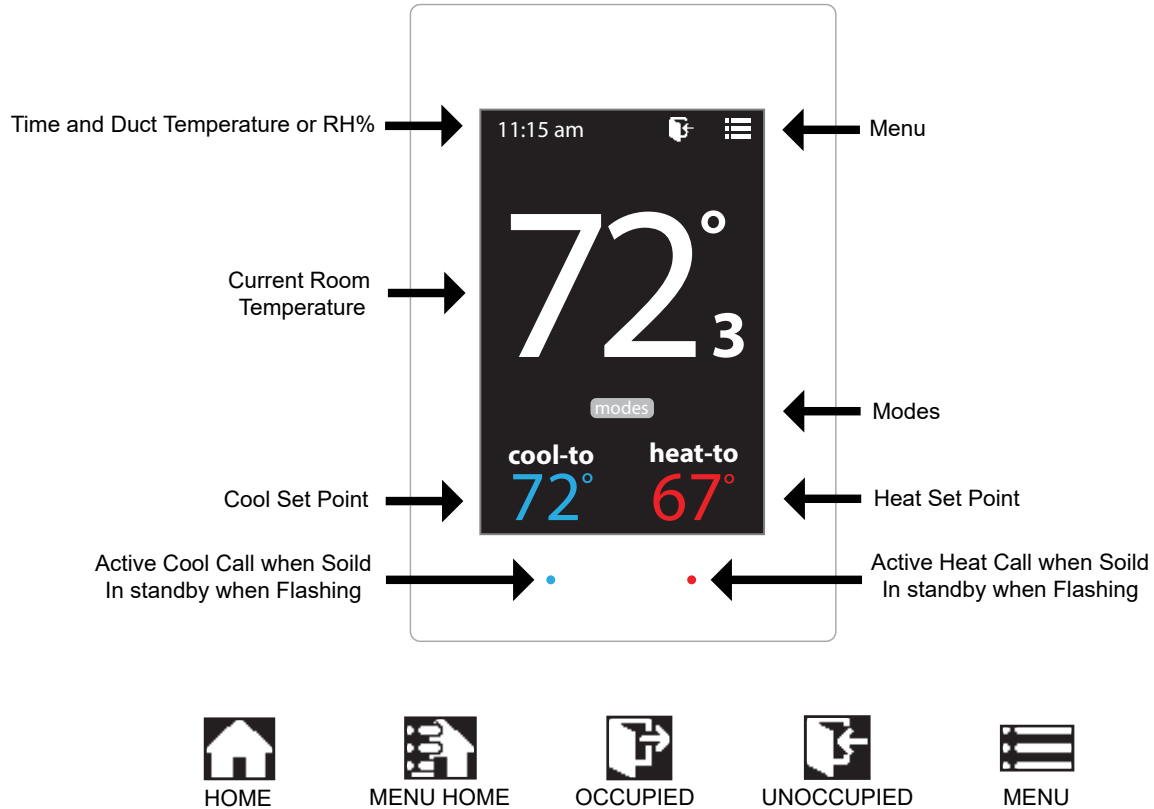

Addressing Zone Thermostats

Every thermostat in the system needs a unique ID ranging from 1-20. They must be in numerical order the way the communication wire is daisy chained. Confirm no duplicate addresses.

To set the stat's ID access the Advanced Configuration menu by tapping on the degree symbol next to the room temp . The degree symbol will change from white to green and then tap .

Once in the Thermostat Advanced Menu, Select **SET ID**

Use the and arrows and set the new ID ranging from 1-20

Tap to save changes, to return to the home screen tap

Select Unit Type

The SATouchX is designed as a universal GAS/ELECTRIC/HEAT PUMP thermostat. Factory default is set for GAS operations.

While in the Thermostat Advanced Menu, Select Unit Type

Select the the desired unit type operation



Tap to save changes, to return to the home screen tap



Display Temperature Calibration

Thermostats are calibrated at the factory and should require no further adjustment. However, the display space temperature may be field calibrated by the following procedure:

To access the Thermostat Configuration Menu: Tap 

While in Thermostat Configuration Menu, Select **Calibrate Display**

Use the  and  arrows to calibrate the thermostat display to a external temperature probe temperature reading.

Tap  to save changes, to return to the home screen tap 

Adjusting Set Points

The Heat or Cool set points are displayed at the bottom of the screen. To adjust the set points, tap on the heat-to or cool-to temperatures; the set points will be displayed on the screen.

Use the  and  arrows over the flame/snowflake icons to set the desired heat and cool set points.

Tap  to save changes

Changing Mode

The thermostats are auto changeover, but specific modes may be selected. Heat/Cool mode is the default.



System Heat/Cool - Tap on , select "Heat/Cool". Tap  to save changes

System Heat Only - Tap on , select "Heat Only". Tap  to save changes

System Cool Only - Tap on , select "Cool Only". Tap  to save changes

System Off - Tap on , select "Off". Tap  to save changes

Override Operation

When the thermostat displays the unoccupied icon  a 2-8 hour temporary override may be initiated by tapping the  "Override" will appear. When additional override time is required, tap the unoccupied icon again.

THERMOSTAT CONFIGURATION MENU

To access the Thermostat Configuration Menu: Tap

The **THERMOSTAT CONFIGURATION MENU** allows you to:

Override/Unoccupied
Set Temperature
Select Occupied Light

Select Unoccupied Light
Mode
Set Display Accuracy

Current Schedule
Time & Date
Temperature F/C

Calibrate Display

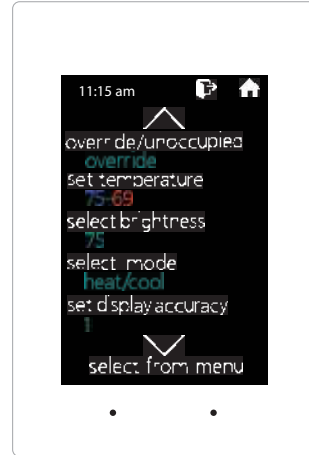
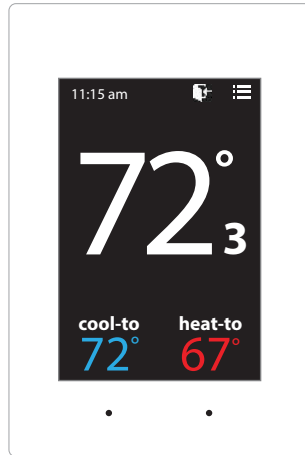

OVERRIDE/UNOCCUPIED

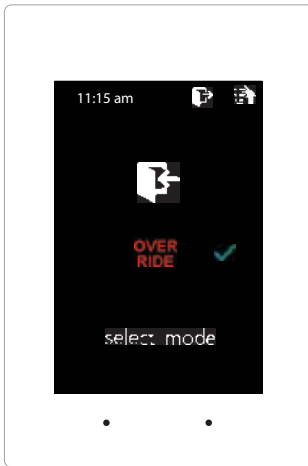

When a thermostat displays "unoccupied mode" , a 2-8 hour temporary override maybe initiated.

While in the Thermostat Configuration Menu, Select **Override/Unoccupied**

Tap "override" to place the thermostat into a override mode.

Tap to save changes, to return to the home screen tap

Shortcut note: Tap on to place the thermostat into override mode

SET TEMPERATURE

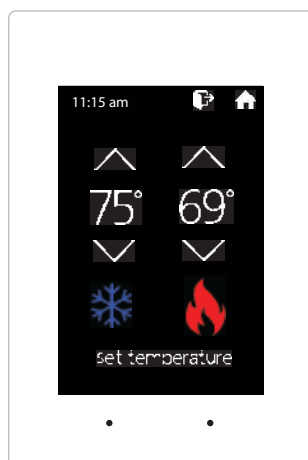

When in the "Set Temperature" screen you can adjust the heat/cool set points to their desired temperature settings.

While in the Thermostat Configuration Menu, Select **Set Temperature**

Use the and arrows over the flame/snowflake icons to set the desired heat and cool set points.

Tap to save changes, to return to the home screen tap

Shortcut note: Tap on cool to/heat to to adjust setpoints.

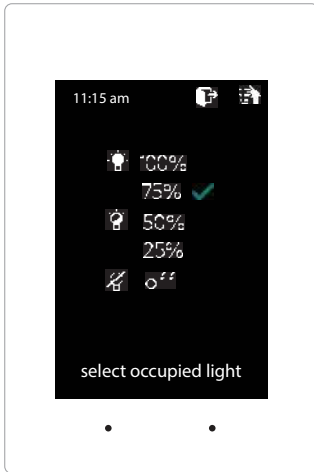

SELECT OCCUPIED LIGHT



The brightness of the thermostat during occupied mode is adjustable from 100% down to off.

While in Thermostat Configuration Menu, Select **Occupied Light**

Use the  and  arrows to select the desired brightness.

Tap  to save changes, to return to the home screen tap 

Note: If "off" is selected, just touch stat to wake it up.

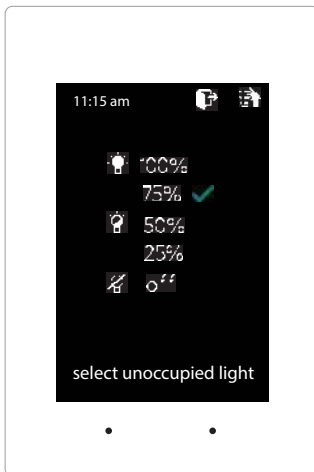

SELECT UNOCCUPIED LIGHT



The brightness of the thermostat during unoccupied mode is adjustable from 100% down to off.

While in Thermostat Configuration Menu, Select **Unoccupied Light**

Use the  and  arrows to select the desired brightness.

Tap  to save changes, to return to the home screen tap 

Note: If "off" is selected, just touch stat to wake it up.

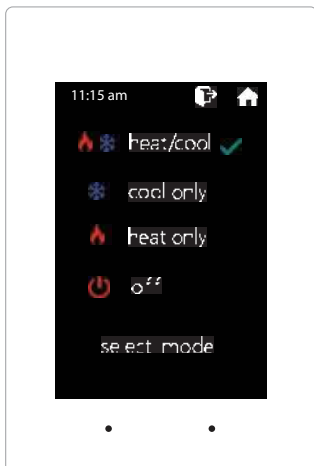

MODE



Thermostat mode allows the thermostat to be set to heat/cool, cool only, heat only or off operation.

While in the Thermostat Configuration Menu, Select **Mode**

Select the desired operation mode

Tap  to save changes, to return to the home screen tap 

Shortcut note: Tap **modes** on the home screen to access the mode selection screen

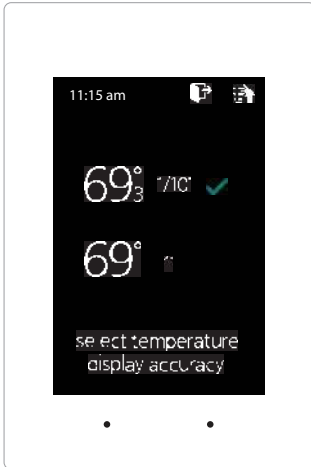

SET DISPLAY ACCURACY



Display accuracy allows the thermostat to display the room temperature in 1/10° or 1°.

While in the Thermostat Configuration Menu, Select **Set Display Accuracy**

Select the desired display accuracy

Tap  to save changes, to return to the home screen tap 

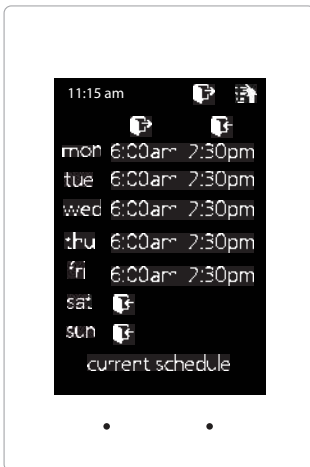

CURRENT SCHEDULE



View the current thermostat schedule, given by the Gen X system

While in the Thermostat Configuration Menu, Select **Current Schedule**

This allows you to view the schedule for that zone. Changes to the schedule are done through the Gen X app.

Tap  to go back to the menu, to return to the home screen tap 

TIME & DATE

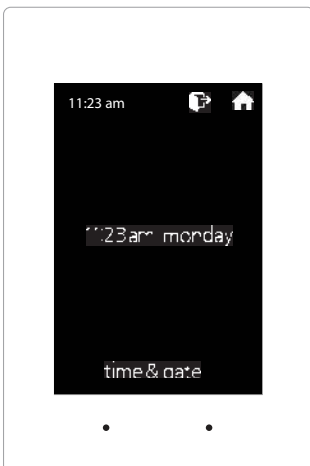

View the current time and day, given by the Gen X system

While in the Thermostat Configuration Menu, Select **Time & Date**

View the current time and date on the Gen X system

Tap  to go back to the menu, to return to the home screen tap 

TEMPERATURE F/C

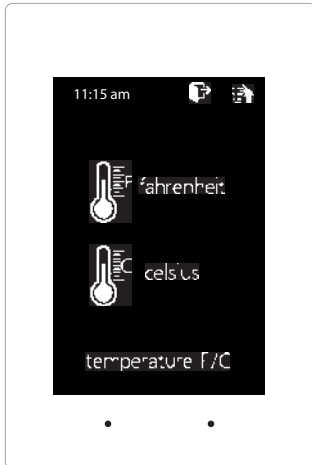

The SATouchX can be configured for F° or C° operation through the Gen X app

While in the Thermostat Configuration Menu, Select **Temperature F/C**

View the current temperature operation



Tap  to go back to the menu, to return to the home screen tap 

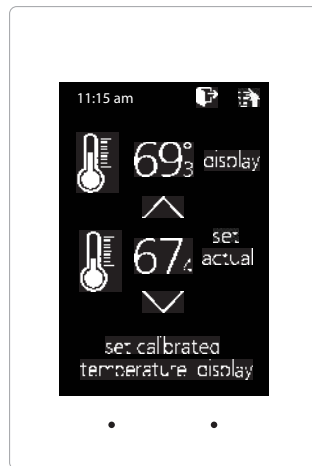

CALIBRATE DISPLAY



Thermostat is equipped with an accurate temperature sensor. If you require field calibration, follow the steps below.

While in Thermostat Configuration Menu, Select **Calibrate Display**

Use the  and  arrows to calibrate the thermostat display to a external temperature probe temperature reading.

Tap  to save changes, to return to the home screen tap 

THERMOSTAT ADVANCED MENU

To access the Thermostat Advanced Menu: Tap on the degree symbol next to the room temp The degree symbol will change color from white to green and then tap

The **THERMOSTAT ADVANCED MENU** allows you to:

Set ID

Select Fan Mode

Set Emergency Heat

Temp Source

Select Unit Type

Set 2nd Stage Temp

Diagnostic

Menu Type

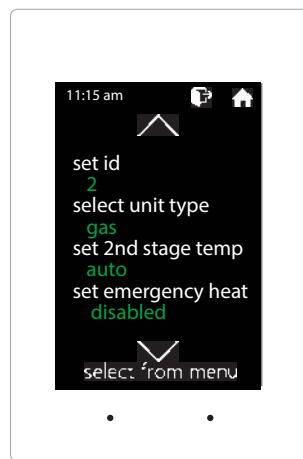
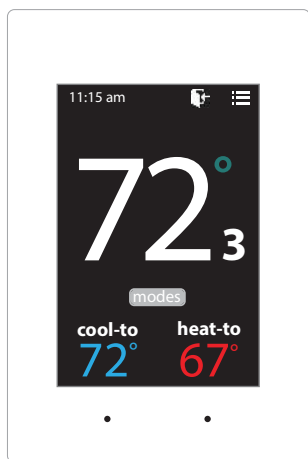

STAT ID

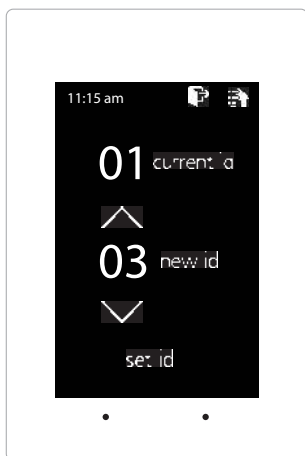

Every thermostat in the system needs a unique ID. They must be ID'ed in numerical order the way the communication wire is daisy chained. No duplicate addresses.

While in the Thermostat Advanced Menu, Select **SET ID**

Use the and arrows to set the new ID ranging from 1-20

Tap to save changes, to return to the home screen tap

Note: (All thermostats receive a unique ID 001 to 020, maximum of 20 zones per GEN X and GEN X RM controllers.)

SELECT UNIT TYPE

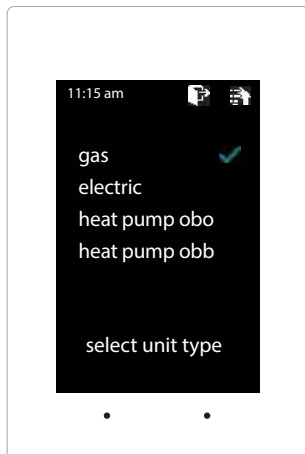

The SATouchX is designed as a universal GAS/ELECTRIC/HEAT PUMP thermostat. Factory default is set for GAS operations.

While in the Thermostat Advanced Menu, Select **Unit Type**

Select the desired unit type operation

Tap to save changes, to return to the home screen tap

SELECT FAN MODE

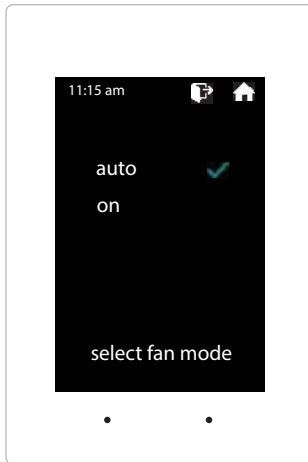

Fan operation is configured for either Fan ON or AUTO. When system is configured for ON operation, the Fan will run during Occupied schedule and will revert to Auto operations during Unoccupied schedule. When thermostat is configured for Auto operation, Fan will only run when there is a call for heating or cooling.

While in the Thermostat Advanced Menu, Select **Fan Mode**

Select the desired fan operation "Auto" or "On".

Tap to save changes, to return to the home screen tap

SET 2ND STAGE TEMP

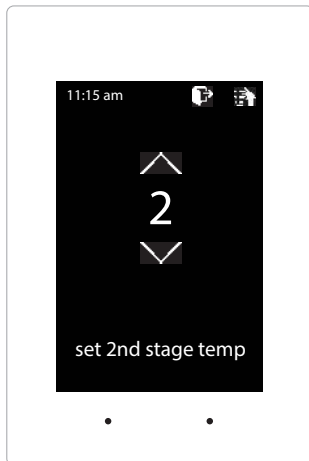

The SATouchX's 2nd stage operation is based on room temperature. Staging is adjustable from 2°- 8° from thermostat room temperature.

While in the Thermostat Advanced Menu, Select **Set 2nd Stage Temp**

Use the and arrows to set the 2nd stage temp range from 2°-8°

Tap to save changes, to return to the home screen tap

SET EMERGENCY HEAT

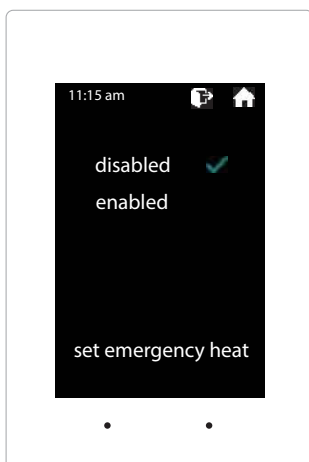

The SATouchX has an emergency heat function that will lock out the compressor, and energize the Aux heat in the unit.

While in the Thermostat Advanced Menu, Select **Set Emergency Heat**

Select "Enabled" for emergency heat operation.

Tap to save changes, to return to the home screen tap

Note: Only emergency heat calls will be seen when enabled.

DIAGNOSTIC

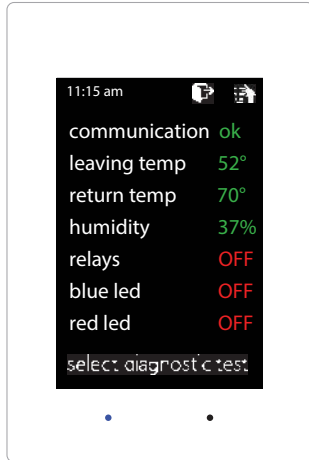

The SATouchX Diagnostic screen will allow you to confirm communication with the GEN X controller and allow you to confirm the relays operation, LED operation and report the leaving/return temperatures as well as the relative humidity.

While in the Thermostat Advanced Menu, Select **Diagnostic**

Tap **relays** to confirm they energize and de-energize
 Tap **blue led** to confirm the blue led illuminates
 Tap **red led** to confirm the red led illuminates

Tap to exit diagnostic screen, to return to the home screen tap

TEMP SOURCE

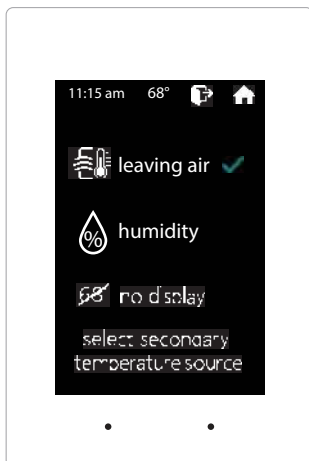

Temp source allows the thermostat to display the leaving air temperature or the relative humidity at the top on the home screen. A LAT sensor needs to be installed to report this reading. It will read 00 if no sensor is installed.

While in the Thermostat Advanced Menu, Select **Temp Source**

Select leaving air, humidity or no display to display or not display the temperature

Tap to save changes, to return to the home screen tap

MENU TYPE

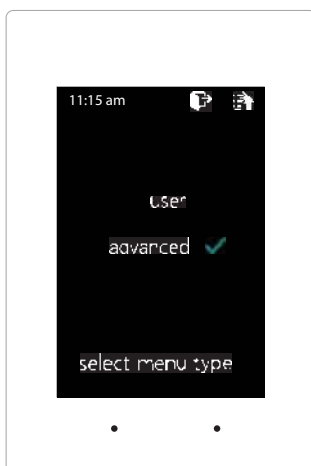

Menu type will allow you to see the advanced menu options under the user menu when advanced is selected.

While in the Thermostat Advanced Menu, Select **Menu Type**

Select **user** to hide the advanced options
 Select **advanced** to show the advanced options under the user menu

Tap to save changes, to return to the home screen tap

GEN X modulating zone dampers are used in cooling/heating systems to provide room by room zone control. The damper is provided with a factory mounted actuator. Each zone damper is controlled by a zone thermostat. More than one damper can be controlled by one zone thermostat. Use this table to determine which zone dampers to use.

DAMPER MODEL	DIFFERENTIAL PRESSURE	MAXIMUM SYSTEM SIZE	MAXIMUM DUCT SIZE
STMPD Round Med. Pressure	1.75"	Any Size	18"
STMRTD Rect. Med. Pressure	1"	6.0 Tons	24"W x 20"H
STCD Rect. Heavy Duty	1.75"	Any Size	48"W x 48"H
STRD Round Heavy Duty	1.75"	Any Size	24"
D-FUSER	0.1"	Any Size	10"

Maximum Differential Pressure refers to the maximum static pressure drop in inches of water column between the input (upstream) of the zone damper and the output (downstream) when the damper is closed.

Round Medium Pressure Zone Dampers

Zonex Systems round (part # STMPD size) medium pressure zone dampers are recommended for systems with a maximum differential static pressure up to 1.75". This modulating power open/power close damper is manufactured from 20-22 gauge galvanized steel with rolled-in stiffening beads for superior rigidity. Mechanical minimum and maximum set stops are provided and are easily adjustable. The damper is elliptical, which allows the airflow to be tracked linearly. The damper pipe is furnished with one crimped end and one straight end for easy installation. Do not install damper in an inverted position. A hat section supports a reversing 24VAC, 60Hz, 2 VA motor. A magnetic clutch allows for continuous power to the motor and longer motor life. Motor drive time from full open to full close is 90 seconds.



MEDIUM PRESSURE (STMPD)

Round Medium Pressure Damper

PART NUMBERS AND SIZES

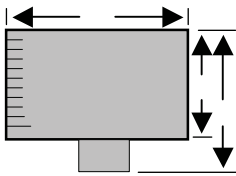

PART#	SIZE	D	L	W
STMPD06	6	6"	10"	9"
STMPD08	8	8"	10"	11"
STMPD10	10	10"	12"	13"
STMPD12	12	12"	14"	15"
STMPD14	14	14"	16"	17"
STMPD16	16	16"	18"	19"
STMPD18	18	18"	23"	21"
STRD20	20	20"	24"	27"
STRD22	22	22"	24"	27"
STRD24	24	24"	24"	27"

Note: Round dampers over 18" will be heavy duty style STRD dampers. Part # STRD size

Typical Round Capacities

These air quantities were derived from a duct sizing chart 0.1" friction loss per 100' of duct. All CFMs

DUCT DIAMETER	NOMINAL CFM	DUCT VELOCITY FPM	DAMPER ΔP " WC
6"	110	540	.014
8"	250	700	.015
10"	410	750	.015
12"	660	850	.022
14"	1000	925	.035
16"	1450	1070	.036
18"	2000	1100	.036
20"	2600	1200	.039
22"	3250	1250	.039
24"	4100	1325	.041

The rectangular zone dampers are available in either medium pressure or heavy duty. For systems under 6 tons, use medium pressure dampers, (part # STMRTD size). For systems 6 tons or over, use heavy duty dampers, (part # STCD size). Motor drive time open and close is 90 seconds.

Rectangular Medium Pressure Zone Dampers (STMRTD)

Zonex Systems rectangular medium pressure dampers are recommended for systems under 6 tons with a maximum differential static pressure of 1". These are fully modulating, power open, power close dampers. They are constructed from heavy duty aluminum and stainless steel. The damper is an opposed blade type that slips into a 3 1/4 - inch wide cutout in the existing duct and attaches with screws via a duct mounting plate. The duct mounting plate is 5 inches wide. A hat section supports a reversing 24vac, 60Hz, 2 VA motor. A magnetic clutch allows for continuous power to the motor and longer motor life. Two set screws connect the motor to the damper shaft, allowing quick motor replacement if necessary. Motor drive time from full open to full close is 90 seconds.



Medium Pressure Rectangular Dimensional Data

Part Number **STMRTD** W x H
 Sizes available from 8" x 6" up to 24" x 20"

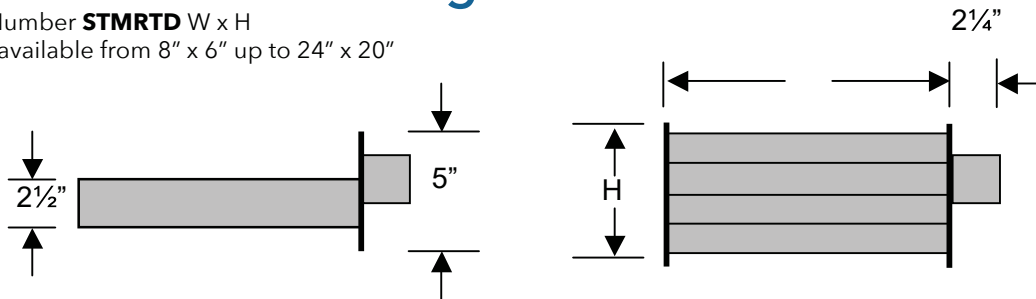

Heavy Duty Rectangular Dimensional Data

Part Number **STCD** W x H
 Sizes available from 8" x 8" up to 48" x 48"

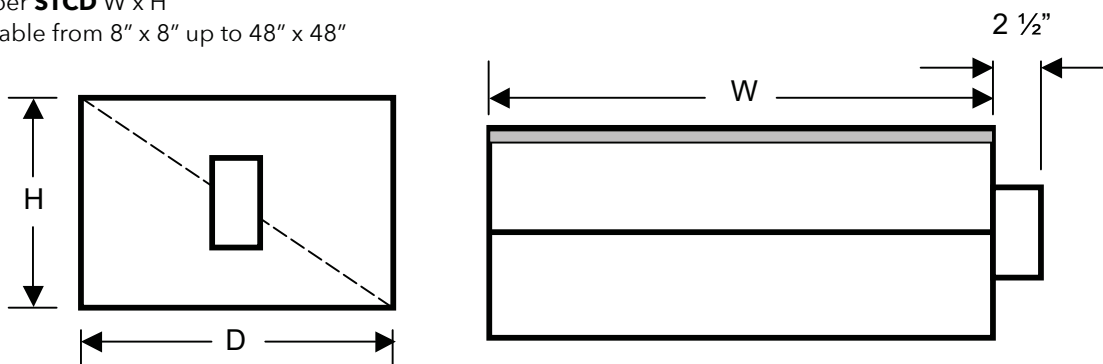

Rectangular Heavy Duty Zone Dampers (STCD)

Zonex Systems rectangular heavy duty dampers are recommended for systems 6 tons or larger with a maximum differential static pressure of 1.75". These are fully modulating, power open / power close dampers made of 20 gauge "snap lock" steel frame with S & Drive duct connections. Allow a 16" gap in the duct for the damper. Formed steel blade stops incorporate a gasket for quiet operation and improved structural rigidity. Rectangular dampers under 10" in height incorporate a single blade design. Dampers 10" or over use opposed blade design. A full stall motor, drawing 2 VA, drives the motor from full open to full close in 90 seconds.



Rectangular Damper Capacities*

		WIDTH IN INCHES																				
		8	10	12	14	16	18	20	22	24	26	28	30	32	34	36	38	40	42	44	46	48
HEIGHT IN INCHES	8	300	400	500	610	710	820	925	1050	1175	1250	1400	1500	1600	1725	1825	2000	2100	2200	2275	2400	2525
	10	400	540	680	825	975	1125	1300	1400	1590	1750	1975	2100	2175	2400	2600	2775	2900	3000	3200	3400	3600
	12	500	680	850	1000	1200	1400	1600	1850	2000	2300	2550	2700	2850	3100	3400	3600	3800	3975	4200	4450	5775
	14	610	825	1000	1250	1500	1750	2000	2250	2500	2900	3150	3425	3625	3825	4200	4600	4800	5000	5300	5750	6000
	16	710	975	1200	1500	1800	2100	2450	2700	3000	3600	3950	4200	4425	4650	5100	5600	5780	6025	6500	7000	7400
	18	820	1125	1400	1750	2100	2500	2850	3080	3600	4400	4600	4950	5100	5600	6000	6500	7000	7150	7600	8100	8600
	20	925	1300	1600	2000	2450	2850	3400	3775	4000	4800	5500	5700	6000	6600	7100	7900	8025	8500	9000	9600	10075
	22	1050	1400	1850	2250	2700	3080	3775	4300	4800	5100	6000	6350	6800	7200	7800	8600	9000	9600	10000	11500	12500
	24	1175	1590	2000	2500	3000	3600	4000	4800	5400	6100	7000	7150	7600	8600	9100	10000	10700	11500	12000	13050	14700
	26	1250	1750	2300	2900	3600	4400	4800	5100	6100	6700	7800	8400	8900	10000	10900	11075	12050	13000	14000	15000	15900
	28	1400	1975	2550	3150	3950	4600	5500	6000	7000	7800	8400	9150	10000	10700	11900	13000	13800	14900	15200	16500	17500
	30	1500	2100	2700	3425	4200	4950	5700	6350	7150	8400	9150	10000	11000	11800	12400	13800	14200	15000	16000	17400	18500
	32	1600	2175	2850	3625	4425	5100	6000	6800	7600	8900	10000	11000	11250	12700	13900	14900	15200	16900	17300	19000	20500
	34	1725	2400	3100	3825	4650	5600	6600	7200	8600	10000	10700	11800	12700	14100	15000	16500	17200	18100	19200	20500	21900
	36	1825	2600	3400	4200	5100	6000	7100	7800	9100	10900	11900	12400	13900	15000	16100	17400	18500	20000	21500	22900	24200
	38	2000	2775	3600	4600	5600	6500	7900	8600	10000	11075	13000	13800	14900	16500	17400	17800	20000	21900	22600	24000	25100
	40	2100	2900	3800	4800	5780	7000	8025	9000	10700	12050	13800	14200	15200	17200	18500	20000	21000	22200	24900	25000	27000
	42	2200	3000	3975	5000	6025	7150	8500	9600	11500	13000	14900	15000	16900	18100	20000	21900	22200	22800	25100	26900	30000
	44	2275	3200	4200	5300	6500	7600	9000	10000	12000	14000	15200	16000	17300	19200	21500	22600	24900	25100	26500	30000	32000
	46	2400	3400	4450	5750	7000	8100	9600	11500	13050	15000	16500	17400	19000	20500	22900	24000	25000	26900	30000	30500	32800
48	2525	3600	5775	6000	7400	8600	1075	12500	14700	15900	17500	18500	20500	21900	24200	25100	27000	30000	32000	32800	35600	

* These air quantities were derived from duct sizing chart .1" friction loss per 100' of duct. All CFMs listed are approximate.
For accurate selection use duct sizing table or

Slaving Up To Three Zone Dampers

Up to three dampers can be directly controlled by one EzTouchX. To wire two or three dampers for a zone, use the following wiring diagram. Remember to size the power transformer for the total number of zone dampers in the system, 2VA per damper.

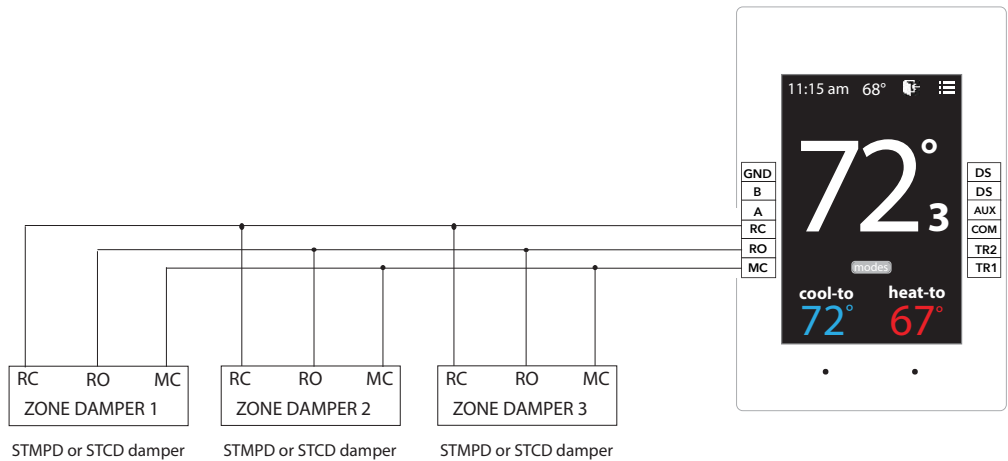

Slaving More Than Three Zone Dampers

When slaving more than three zone dampers, use the following diagram. An additional 24VAC and control relays are needed for these applications.

Note: All slave dampers need to be model STMPD / STCD

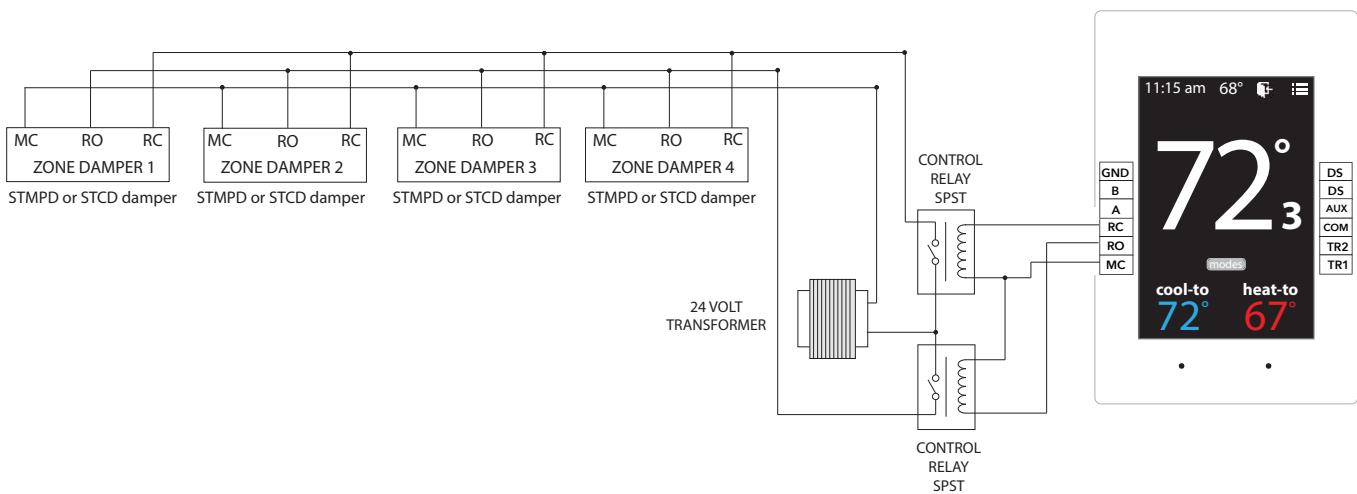

BYPASS DAMPERS - ELECTRONIC

with integrated static pressure control

Electronic Bypass Dampers

Modulating Bypass dampers are used to provide constant air delivery through the air handling unit. This is done by bypassing excess air from the supply duct back to the return duct. As a zone is satisfied, its zone damper closes. When this happens, the bypass damper modulates just enough to bypass the excess air. This will control static pressure and noise at the diffusers.

The Electronic Bypass Damper is used on any size system. The damper can be round (**STBP**) or rectangular (**STCDBP**) with integrated static pressure control; and multiple dampers can be slaved together.

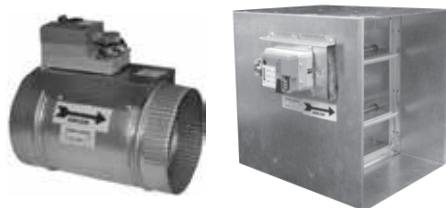

Sizing Electronic Bypass Dampers

The bypass damper is to be sized for the total system CFM @ 1500 FPM. System CFM should be calculated at 400 CFM per ton.

Example: A 5-ton system is rated at 2000 CFM (5x400 = 2000). When calculated at 1500 FPM, the bypass damper should be 16". Never undersize the bypass damper.

ROUND BYPASS SELECTION

DIAMETER	CFM	PART #	SIZE	D	L	W
8"	560	STBP08	8	8"	10"	11"
10"	900	STBP10	10	10"	12"	13"
12"	1250	STBP12	12	12"	14"	15"
14"	1700	STBP14	14	14"	16"	17"
16"	2200	STBP16	16	16"	18"	19"
18"	2600	STBP18	18	18"	23"	21"
20"	3300	STRDBP20	20	20"	24"	27"
22"	4000	STRDBP22	22	22"	24"	27"
24"	4700	STRDBP24	24	24"	24"	27"

Round Bypass Damper Selection

The Zonex Systems STBP damper is used for round bypass applications. When you know the bypass CFM requirements, use the ROUND BYPASS SELECTION TABLE to confirm the round damper size.

NOTE: Multiple round dampers can be slaved from one static pressure control to provide the correct capacity. One large rectangular bypass damper may be used instead of multiple round dampers. See below.

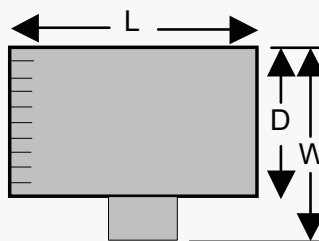

Rectangular Bypass Damper Selection

The Zonex Systems **STCDBP WxH** damper is used for rectangular bypass applications. These dampers are also sized for the total system CFM rated at 1500 FPM. Multiple dampers can be slaved from a single static pressure control.

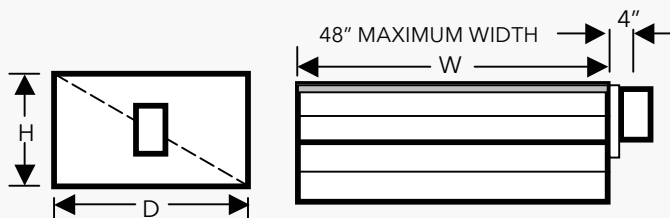

RECTANGULAR BYPASS DAMPERS
SELECT FROM 8 x 8 thru 48 x 48

RECTANGULAR BYPASS SELECTION TABLE

		WIDTH IN INCHES														
		8	10	12	14	16	18	20	22	24	28	32	36	40	44	48
HEIGHT IN INCHES	8	667	833	1000	1167	1333	1500	1667	1833	2000	2333	2667	3000	3333	3667	4000
	10	833	1042	1250	1458	1667	1875	2083	2292	2500	2917	3333	3750	4167	4583	5000
	12	1000	1250	1500	1750	2000	2250	2500	2750	3000	3500	4000	4500	5000	5500	6000
	14	1167	1458	1750	2042	2333	2625	2917	3208	3500	4083	4667	5250	5833	6417	7000
	16	1333	1667	2000	2333	2667	3000	3333	3667	4000	4667	5333	6000	6667	7333	8000
	18	1500	1875	2250	2625	3000	3375	3750	4125	4500	5250	6000	6750	7500	8250	9000
	20	1667	2083	2500	2917	3333	3750	4167	4583	5000	5833	6667	7500	8333	9167	10000
	22	1833	2292	2750	3208	3667	4125	4583	5042	5500	6417	7333	8250	9167	10083	11000
	24	2000	2500	3000	3500	4000	4500	5000	5500	6000	7000	8000	9000	10000	11000	12000
	28	2333	2917	3500	4083	4667	5250	5833	6417	7000	8167	9333	10500	11667	12833	14000
	32	2667	3333	4000	4667	5333	6000	6667	7333	8000	9333	10667	12000	13333	14667	16000
	36	3000	3750	4500	5250	6000	6750	7500	8250	9000	10500	12000	13500	15000	16500	18000
	40	3333	4167	5000	5833	6667	7500	8333	9167	10000	11667	13333	15000	16667	18333	20000
	44	3667	4583	5500	6417	7333	8250	9167	10083	11000	12833	14667	16500	18333	20167	22000
	48	4000	5000	6000	7000	8000	9000	10000	11000	12000	14000	16000	18000	20000	22000	24000

Bypass air in CFM. Calculated at 1500 FPM.

Formula used: $B = W \times H / 144 \times 1500$, where B = Bypass air in CFM, W = damper width in inches, H = damper height in inches, 144 = 144 sq. inches per sq. ft., 1500 = 1500 FPM.

ROUND AND RECTANGULAR BYPASS DAMPER MOTORS

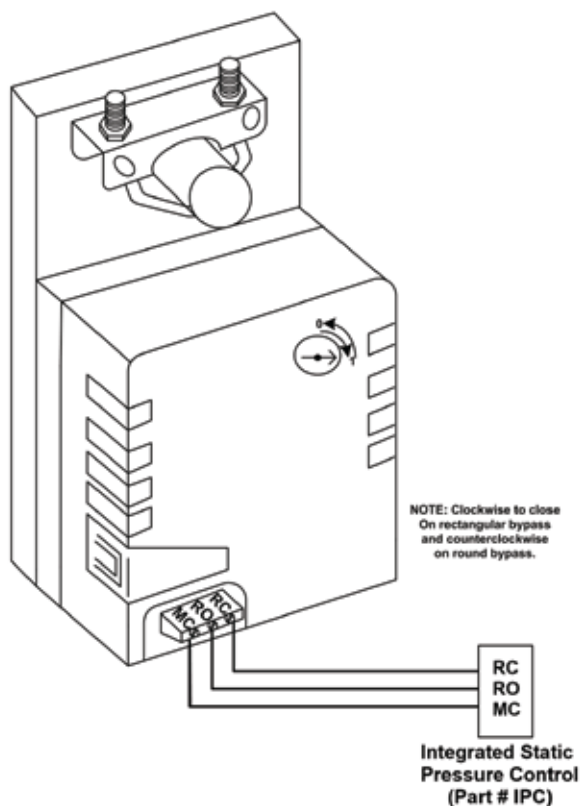

Slaving Bypass Dampers

Use only one Pressure Sensor when slaving two or more Bypass Dampers together. Connect the Pressure Sensor to one damper as described above. Connect the slave dampers in parallel as shown. Up to 4 dampers can be slaved to one Sensor. The slaved dampers will self-synchronize each time the dampers reach full open or full close.

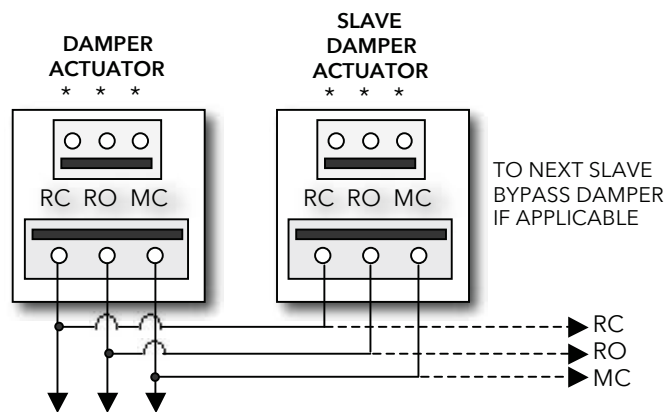

To Static Pressure Control, as shown on the Bypass Wiring Diagram on the next page.

INSTALLATION

The round and rectangular bypass damper can be installed in any position. Do not run speed screws into damper housing. Screws may interfere with damper travel.

1. Install the bypass damper between the supply and return plenums of the unit. It must be the first tap off the supply plenum. (Bypass damper sizing is recommended for 100% of system CFM.)
2. Be sure the air flows through the damper in the proper direction as indicated by the arrow on the damper. Airflow is always from supply to return plenum.
3. Do not install the bypass damper outside.
4. Bypass damper and controller are powered by a dedicated 24vac 40VA transformer.
5. Follow the steps on the next page for Integrated Pressure Controller installation and set up.

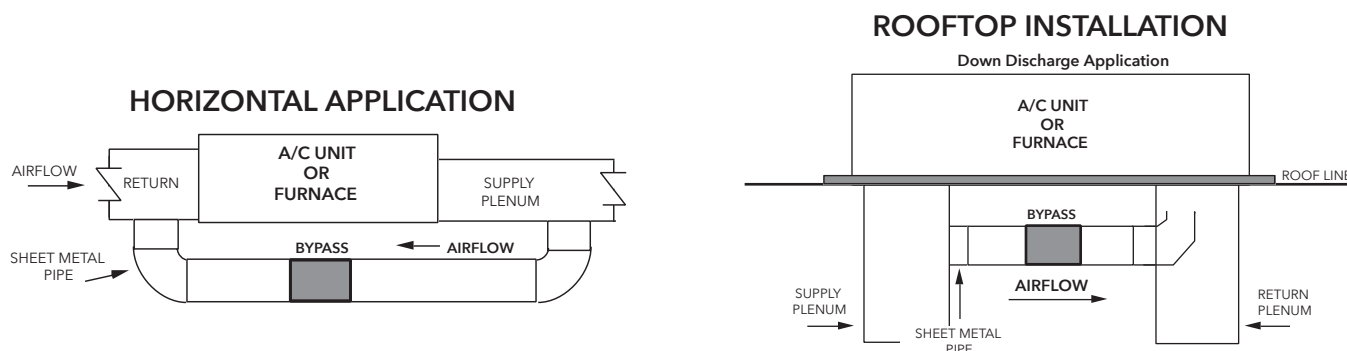

OPEN RETURN PLENUM AND BYPASS APPLICATION

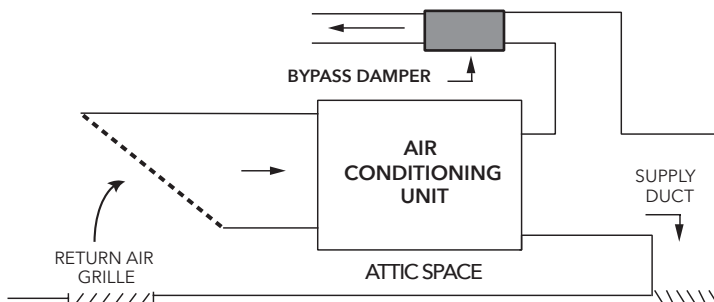

OPEN RETURN PLENUM BYPASS APPLICATION

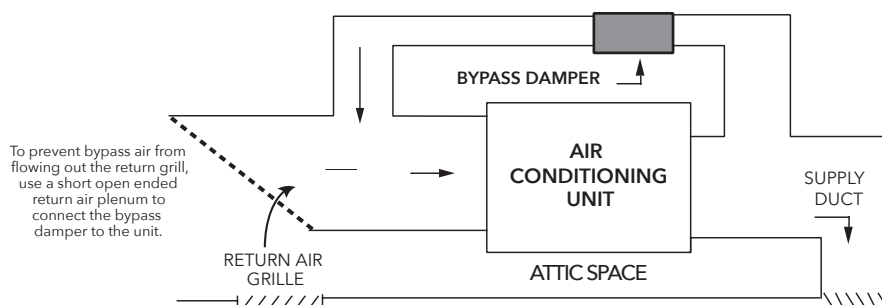

INTEGRATED STATIC PRESSURE CONTROL SETUP

Bypass Damper with Integrated Pressure Control is used to control bypass operations. The bypass damper modulates to maintain static pressure as zone dampers open and close. The bypass system reduces air noise from the supply registers caused by excessive air velocity. If the system is configured for intermittent fan mode and the system satisfies, there will be a 3-minute delay to allow for system purge, after which the bypass damper will open to 25%, preventing noisy rush of air through supply registers when fan starts up on a call for heat or cool. If the system is configured for fan continuous operation, the **STBP** (Round) or **STCDBP** (Rectangular) Electronic Bypass will monitor static pressure continuously, providing constant control of system static.

Integrated Pressure Control Description

- A. Supply air tube
- B. 24vac R and C
- C. Damper Terminal RO, RC, MC
- D. LED lights
- E. Adjustable Potentiometer
- F. TP1 Test Point

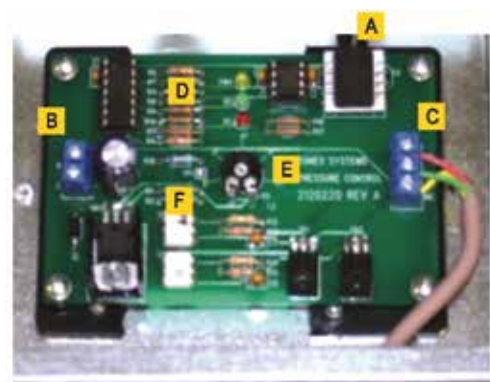

Fig. 1

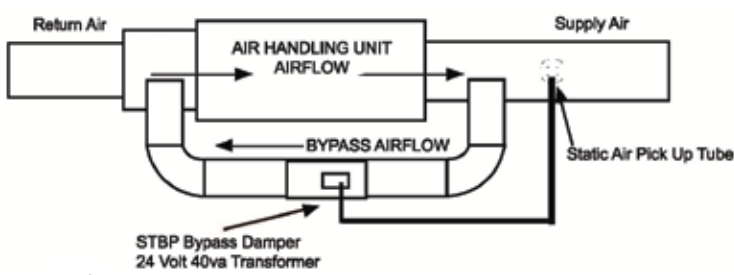

Fig. 2



1. Locate the Integrated Pressure Control (IPC) and air tube on the bypass damper. Drill hole into the side of the supply duct 2' after the bypass and before the 1st supply take-off.
2. Mount pressure supporting block over hole, align hole in block with hole in duct. Use provided sheet metal screws.
3. Install air tube into supply air duct by slipping supplied plastic tubing into holes in support block and duct. Slip tube 3" into the duct. Pickup tubing fits snugly into provided hole.
4. Connect pressure tube from static air pickup to Integrated Pressure Controller (port closest to you).

Bypass Damper With Integrated Bypass Control Setup

1. Run all supply dampers to the full open position and have blower motor running at 100% fan speed. (See Note #1)
2. Manually close the bypass damper by pressing in the release lever on the motor side of the actuator. With the release lever pressed, rotate the damper actuator collar to close the damper and release the lever to lock the damper closed.
3. **Quick Set Option:** Turn the potentiometer on the damper control board to the full left position and slowly rotate RIGHT, until the "RC" RED LED turns on. Now rotate LEFT just slightly, until RC LED turns off. The **IPC** is ready for operation.

"RC" RED LED means damper closing.
 "RO" GREEN LED means damper opening.

- Static Pressure Option: The Integrated Pressure Control Board can be field configured for specified static pressure using a multi meter and the static pressure - voltage chart. (Exhibit A). This chart shows voltage (DC) to inches of W.C. (static pressure) relationship. Use a multi meter set on VDC and place the leads on the "C" terminal and "TP1" (test point one) next to the potentiometer. The Voltage reading translates to inches of W.C.

Bypass Checkout For Static Pressure Controller

- Make cool call at the zone thermostat of the smallest zone.
- Verify all zone dampers are closed except for calling zone.
- Verify noise at zone registers is not excessive. Adjust the Integrated Pressure Control LEFT to lower noise (airflow) or RIGHT to increase airflow until to noisy.

Static Pressure Voltage Chart

STATIC PRESSURE	TP1	STATIC PRESSURE	TP1
INCH W.C.	VOLTAGE (DC)	INCH W.C.	VOLTAGE (DC)
0.1	1.49	0.5	2.22
0.15	1.62	0.55	2.27
0.2	1.69	0.6	2.42
0.25	1.81	0.65	2.48
0.3	1.85	0.7	2.6
0.35	1.91	0.75	2.68
0.4	1.94	0.8	2.81
0.45	2.06	N/A	N/A

EXHIBIT A

Note # 1: To open all dampers, it may be necessary to remove Y outputs to unit on the zone control board and to make full cool calls on all thermostats. This will modulate dampers fully open and lock out compressor.

On GEN X use air balance mode on the mobile App for simplified bypass setup.

Bypass Damper Wiring Diagram With Integrated Bypass Control

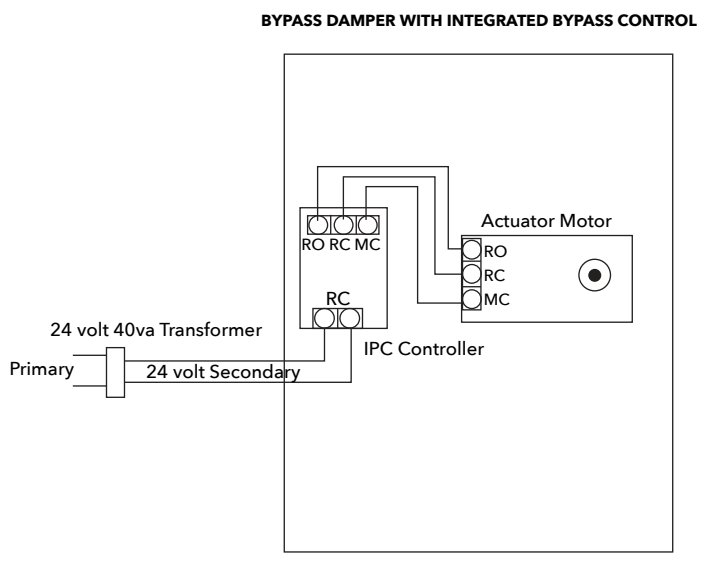



NETWORK ALL YOUR HVAC EQUIPMENT

Monitor, update and control System Information from the mobile app

Centralized DDC Communications for
Stand-Alone HVAC and Zoned Modulating Systems

Designed to centralize control of
multiple constant volume VAV systems

HOTLINE

(800) 228-2966



5622 Engineer Drive
Huntington Beach, CA 92649
Factory (714) 898-9963
Fax (714) 898-6802

VISIT OUR WEBSITE

www.zonexproducts.com

PATENTED PRODUCT

Zonex Systems reserves the right to discontinue,
or change at any time, specifications or designs
without notice and without incurring obligations
Copyright 2020 by Zonex Systems

THE EASIEST WAY TO GET QUOTES FAST
WWW.ZONEXPRODUCTS.COM

PART # GENXMAN
July 2021