

BRAY

RESILIENT SEATED BUTTERFLY VALVES

Installation, Operation and Maintenance Manual

20/21 | 22/23 | 30/31 | 3A/3AH | 31H | 31U | 32/33 | 35/36 | 36H

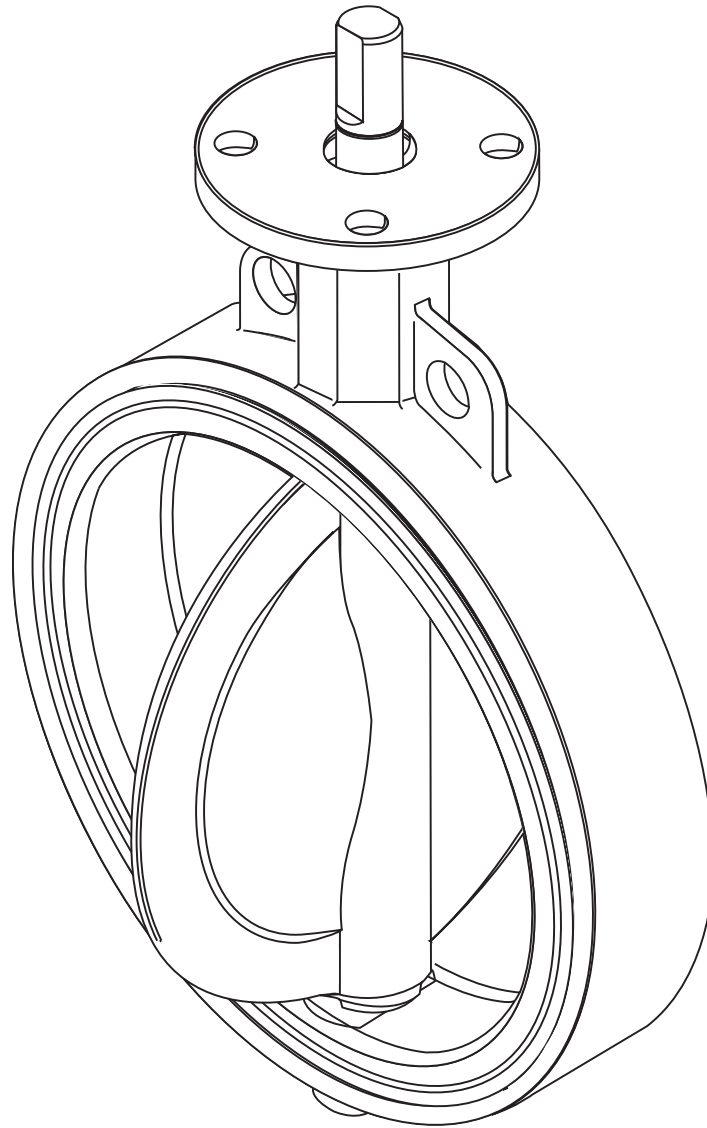

 **Bray**[®]

Table of Contents

1.0	Safety Instructions - Definition of Terms	3
2.0	Introduction	3
3.0	Installation Considerations - Piping and Valve Orientation and Placement	5
4.0	Installation Procedure	10
5.0	Maintenance and Repair	14
APPENDIX - Disassembly/Assembly Instructions		16
6.0	Appendix A - Series 20/21 Resilient Seated Butterfly Valves	16
7.0	Appendix B - Series 22/23 Resilient Seated Butterfly Valves	18
8.0	Appendix C - Series 30/31 Resilient Seated Butterfly Valves	20
9.0	Appendix D - Series 3A/3AH Resilient Seated Butterfly Valves	22
10.0	Appendix E - Series 31H Resilient Seated Butterfly Valves	24
11.0	Appendix F - Series 31U Resilient Seated Butterfly Valves	26
12.0	Appendix G - Series 32/33 Resilient Seated Butterfly Valves	28
13.0	Appendix H - Series 35/36 Resilient Seated Butterfly Valves (Taper Pin Disc/Stem Connection)	30
14.0	Appendix I - Series 35/36 Resilient Seated Butterfly Valves (Internal Spiine or Keyed Disc/Stem Connection)	32
15.0	Appendix J - Series 36H Resilient Seated Butterfly Valves	36



**READ AND FOLLOW THESE INSTRUCTIONS CAREFULLY.
SAVE THIS MANUAL FOR LATER USE.**

1.0 SAFETY INSTRUCTIONS - DEFINITION OF TERMS

WARNING

Indicates a potentially hazardous situation which, if not avoided, could result in death or serious injury.

CAUTION

Indicates a potentially hazardous situation which, if not avoided, may result in minor or moderate injury.

NOTICE

Used without the safety alert symbol, indicates a potential situation which, if not avoided, may result in an undesirable result or state, including property damage.

2.0 INTRODUCTION

2.1 Historical Experience

2.1.1 Based on over thirty years experience in the butterfly industry, Bray can state without question the majority of all field problems for resilient seated butterfly valves are directly related to poor installation procedures. For this reason, it is very important all distributor salespeople educate their customers regarding proper installation of resilient seated butterfly valves.

2.2 Butterfly Valve Seat / Disc Function

2.2.1 Before reviewing the proper installation, maintenance, and repair procedures for resilient seated butterfly valves, let's discuss the seat-disc function of a butterfly valve. The seat in a resilient seated butterfly valve has molded o-rings on its flange face. As a result, no gaskets are required as these o-rings serve the function of a gasket. The flange face and molded o-rings of the seat extend beyond the body face-to-face to ensure sealing at the flange faces. The seat material, which extends past the face is compressed in installation and flows toward the center of the valve seat I.D.

- 2.2.2 In essence, the elastomer seat acts as a liquid, and the displaced elastomer moves toward the point of least resistance. The seat I.D. of all resilient seated butterfly valves is smaller than the disc O.D. This difference, the disc-seat interference, plus the increased interference due to the elastomer movement toward the seat center after installation, has been engineered so as to be the basis for pressure rating capability and the related seating/unseating torques. Any change in this interference due to improper installation directly affects the pressure rating and seating/unseating torques.
- 2.2.3 Finally, unlike many valve types, the resilient seated butterfly valve's disc actually extends beyond the face of the valve body at given angles of opening (say, 30° or more) when installed between flanges.

CAUTION

It is very important before installation to ensure the critical chordal dimension of the disc at the full open position is less than the adjacent pipe flange I.D.

2.3 Shipment and Storage

- 2.3.1 The seat, disc, stem and bushing of the resilient seated butterfly valve should be coated with silicone lubricant unless specified otherwise
- 2.3.2 The disc should be positioned at 10° open. **Note:** See page 2 for special considerations for valves with spring return actuators.
- 2.3.3 Valves should be stored indoors with a preferred temperature range from 40°F (4°C) to 85°F (29°C).
- 2.3.4 While valves are in storage, they should be opened and closed once every 3 months.
- 2.3.5 Ship and store valves so that no heavy loads are applied to the bodies.
- 2.3.6 Polymer and elastomer parts should not be stored in the presence of sunlight or artificial light with high ultraviolet content, or any source of radiation as these are primary causes of aging.
- 2.3.7 If a component is cooled below 59°F (14°C), the entire valve assembly should be allowed to rise above 68°F (20°C) before installing into service.
- 2.3.8 Valve end protectors should only be removed at the time of valve installation.

3.0 INSTALLATION CONSIDERATIONS - PIPING AND VALVE ORIENTATION AND PLACEMENT

3.1 Piping and Flanged Compatibilities

3.1.1 Piping

3.1.1.1 These valves have been engineered so that the critical disc chord dimension at the full open position will clear the adjacent inside diameter of most types of piping, including Schedule 40, lined pipe, heavy wall, etc.

3.1.2 Metal Flanges

3.1.2.1 Resilient seated butterfly valves have been designed to be suitable for all types of flanges (ASME, DIN, JIS and other international flange standards), whether flat-faced, raised face, slip-on, weld-neck, etc. Proper alignment of any butterfly valve between flanges is critical to good performance of the valve. The flange bolts must also be evenly tightened around the circumference of the valve, providing consistent flange compression of the molded o-ring in the seat face.

3.1.2.2 Since Bray does not recommend the use of gaskets between flanges on resilient seated butterfly valves, a uniform flange face is critical to proper valve sealing. Most weld-neck and slip-on flanges conforming to ASME specifications have an appropriate flange face. Types A and B butt-weld stub-end flanges also provide a suitable mating surface for the molded o-ring.

3.1.2.3 It should be noted that Type C butt-weld stub-end flanges have an “as formed” flange face. The varying surface of this flange face can create sealing problems between any resilient-seated butterfly valve and the flange face. For this reason, Type C flanges are not recommended for use with resilient-seated butterfly valves.

3.1.3 Non-Metallic Flanges

3.1.3.1 When non-metallic flanges, such as plastic or PVC, are used with resilient seated butterfly valves, care must be taken not to over-tighten the flange bolts. The inherent flexibility of these non-metallic flange materials allow them to be over-tightened relatively easily. Flexing caused by this over-tightening can actually reduce the compression of the valve between the flanges, causing leaks between the valve and the flange face. Proper alignment and firm, even, but not excessive tightening of flange bolts are especially important with non-metallic flanges. In some cases, non-metallic flanges of low quality will not mate tightly with butterfly valves regardless of the care taken during installation.

3.2 Valves with Spring Return Actuators

3.2.1 Fail Closed Assemblies

3.2.1.1 If the valve is supplied with an actuator, the butterfly valve is shipped in the full closed position (as no air pressure is present to compress the springs and open the disc).



Installing the valve with the disc in the full closed position may create a compression set on the seat causing higher than expected torques or premature seat failure. It is recommended to:

- > Remove the actuator. Be sure to scribe the valve and actuator to ensure the re-installed actuator is in the exact same quadrant as originally configured
- > Install the valve per the attached installation tag instructions
- > Re-install the actuator ensuring it is in the proper quadrant

3.2.2 Fail Open Assemblies

3.2.2.1 If the valve is supplied with an actuator, the butterfly valve disc is shipped in the full open position (as no air pressure is present to compress the springs and close the valve disc.) The sealing surface, or disc edge, is therefore exposed. Damage to that surface will cause premature seat failure.



Use caution installing the valve being careful not to damage the disc edge. It is recommended to:

- > Remove the actuator. Be sure to scribe the valve and actuator to ensure the re-installed actuator is in the exact same quadrant as originally configured
- > Install the valve per the attached installation tag instructions
- > Re-install the actuator ensuring it is in the proper quadrant.

3.2.3 Valve Location

3.2.3.1 Resilient seated butterfly valves should be installed if possible a minimum of 6 pipe diameters from other line elements, i.e., elbows, pumps, valves, etc. of course, 6 pipe diameters are not always practical, but it is important to achieve as much distance as possible.

3.2.3.2 Where the resilient seated butterfly valve is connected to a check valve or pump, use an expansion joint between them to ensure the disc does not interfere with the adjacent equipment.

3.2.4 Valve Orientation

- 3.2.4.1 In general, Bray recommends the resilient seated valve be installed with the stem in the vertical position and the actuator mounted vertically directly above the valve; however, there are those applications as discussed below where the stem should be horizontal. NOTE: Bray does not recommend valves be installed in an upside-down position.
- 3.2.4.2 For slurries, sludge, mine tailing, pulp stock, dry cement, and any media with sediment or particles, Bray recommends the resilient seated valve be installed with the stem in the horizontal position with the lower disc edge opening in the downstream direction as illustrated below.

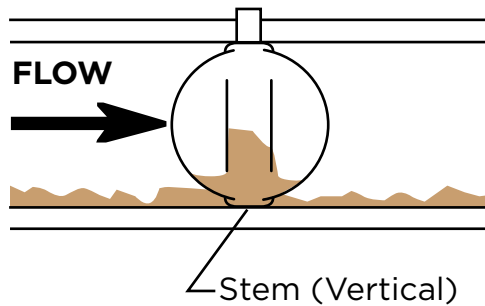

Incorrect Installation

Sludge builds up on the disc

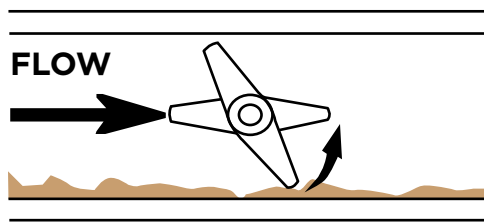

Stem (Horizontal)

Correct Installation

Sludge passes under the disc

3.2.4.3 Resilient seated butterfly valve located at the discharge of a pump should be oriented as follows:

	INCORRECT INSTALLATION	CORRECT INSTALLATION
1. Centrifugal Pump Pump shaft horizontal and stem vertical	<p>Pump Shaft (Horizontal)</p> <p>Stem (Horizontal)</p> <p>FLOW</p>	<p>Pump Shaft (Horizontal)</p> <p>Stem (Vertical)</p> <p>FLOW</p>
2. Centrifugal Pump Pump shaft vertical and stem horizontal	<p>Pump Shaft (Vertical)</p> <p>Stem (Vertical)</p> <p>FLOW</p> <p>Suction</p>	<p>Pump Shaft (Vertical)</p> <p>Stem (Horizontal)</p> <p>FLOW</p> <p>Suction</p>
3. Axial Pump Pump shaft vertical and stem vertical	<p>Pump Shaft (Vertical)</p> <p>Stem (Horizontal)</p> <p>FLOW</p> <p>Suction</p>	<p>Pump Shaft (Vertical)</p> <p>Stem (Vertical)</p> <p>FLOW</p> <p>Suction</p>

3.2.4.4 Butterfly valves located downstream of a bend or pipe reducer should be oriented as follows:

	INCORRECT INSTALLATION	CORRECT INSTALLATION
1. Bend	<p>Stem (Horizontal)</p> <p>FLOW</p>	<p>Stem (Vertical)</p> <p>FLOW</p>
2. Tee	<p>Stem (Horizontal)</p> <p>FLOW</p>	<p>Stem (Vertical)</p> <p>FLOW</p>
3. Pipe Reducer	<p>Stem (Horizontal)</p> <p>FLOW</p>	<p>Stem (Vertical)</p> <p>FLOW</p>

3.2.4.5 Butterfly valves in combination for control/isolation applications should be installed as follows:

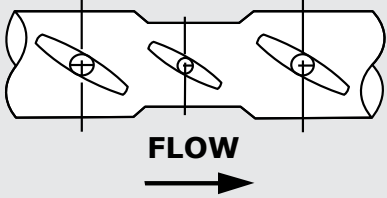
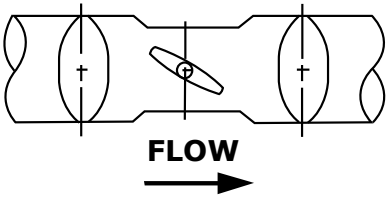
INCORRECT INSTALLATION	CORRECT INSTALLATION
 <p>Combination with all valve stems in the same direction accelerates possible noise, vibration, and erosion problems.</p>	 <p>Combination with the stem of the control valve at right angle to those of other valves tends to cancel the drift of the fluid, and reduces noises, vibration, and erosion.</p>

4.0 INSTALLATION PROCEDURE

4.1 General Installation



- 4.1.1 Make sure the pipeline and pipe flange faces are clean. Any foreign material such as pipe scale, metal chips, welding slag, welding rods, etc., can obstruct disc movement or damage the disc or seat.
- 4.1.2 The Bray elastomer seat has molded o-rings on the face of the seat. **As a result, no gaskets are required as these o-rings serve the function of a gasket.**
- 4.1.3 Align the piping and then spread the pipe flanges a distance apart so as to permit the valve body to be easily dropped between the flanges without contacting the pipe flanges (see Figure 1 page 11).
- 4.1.4 Check to see that the valve disc has been positioned to a partially open position, with the disc edge about 1/2 inch to 3/8 inch inside the face of the seat, (approximately 10° open) **(see Figure 1 page 11) Note: See page 6 for special consideration for valves with spring return actuators.**
- 4.1.5 Insert the valve between the flanges as shown in Figure 1 of page 11, taking care not to damage the seat faces. Always pick the valve up by the locating holes or by using a nylon sling on the neck of the body.



WARNING

Never pick up the valve by the actuator or operator mounted on top of the valve.

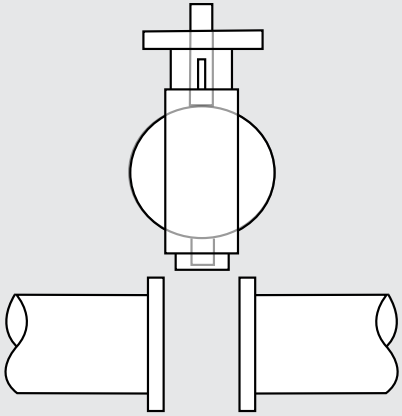
Figure 1 - Insert Resilient Seated Butterfly Valve Between Flanges

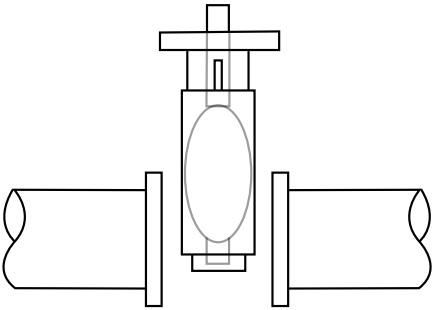
INCORRECT INSTALLATION	CORRECT INSTALLATION
 <div data-bbox="164 810 792 894" style="background-color: yellow; text-align: center; padding: 5px;">  CAUTION </div> <p data-bbox="172 905 784 995">Pipe not spread, disc opened beyond valve body face; Results: Disc edge damaged when it hits pipe flange.</p>	 <p data-bbox="821 804 1382 894">Pipe spread and aligned, disc rotated; Results: no undesirable beginning seating/unseating torque, disc edge protected.</p>

4.1.6 Place the valve between the flanges, center it, and then span the valve body with all flange bolts, but do not tighten the bolts. Carefully open the disc to the full open position, making sure the disc does not hit the adjacent pipe I.D. Now systematically remove jack bolts or other flange spreaders, and hand-tighten the flange bolts as shown in Figure 2 below. Very slowly close the valve to ensure disc edge clearance from the adjacent pipe flange I.D. Now open the disc to full open and tighten **all** flange bolts per specification as shown in **Figure 2**. Finally, repeat a full close to full open rotation of the disc to ensure proper clearances (See Figures 3 & 4 page 7).

Figure 2 - Flange Bolt Tightening Pattern

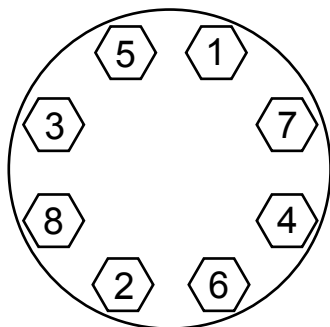

4.1.7 For additional flange bolting information please reference the Resilient Seated Butterfly Valve Technical Manual and “Typical Flange Bolting Guide” found at www.bray.com

Figure 3 - Initial Centering and Flanging of Valve

INCORRECT INSTALLATION	CORRECT INSTALLATION
 <p>Disc in closed position; gaskets used; Results: Seat distorted and over-compressed causing high initial unseating torque problems.</p>	 <p>Bolts snugged, not torqued tight, disc edge within body face-to-face but not fully closed, no flange gaskets; Results: No disc edge damage, proper sealing allowed.</p>

Figure 4 - Final Aligning and Tightening of Flange Bolts

INCORRECT INSTALLATION	CORRECT INSTALLATION
 <p>Piping misaligned; Results: Disc O.D. strikes pipe I.D. causing disc edge damage, increased torque & leakage. Seat face o-rings will not seal properly with incorrectly aligned piping.</p>	 <p>Piping aligned properly when bolts tightened, disc in full open position; Results: disc clears adjacent pipe I.D., seat face seals properly, no excessive initial torque.</p>

4.1.8 When resilient seated butterfly valves are to be installed between ASME welding type flanges, care should be taken to abide by the following procedure to ensure no damage will occur to the seat:

- 4.1.8.1 Place the valve between the flanges with the flange bores and valve body aligned properly. The disc should be in the 10° open position.
- 4.1.8.2 Span the body with the bolts.
- 4.1.8.3 Take this assembly of flange-body-flange and align it properly to the pipe.
- 4.1.8.4 Tack weld the flanges to the pipe.
- 4.1.8.5 When tack welding is complete, remove the bolts and the valve from the pipe flanges and complete the welding of the flanges. Be sure to let the pipe and flanges cool before installing the valve.

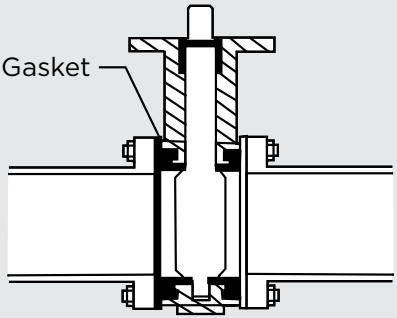
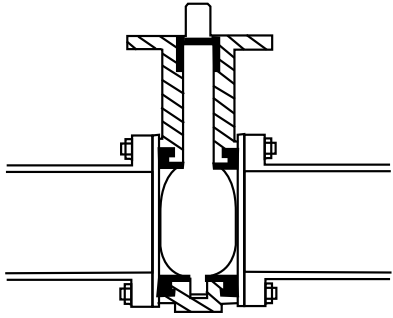
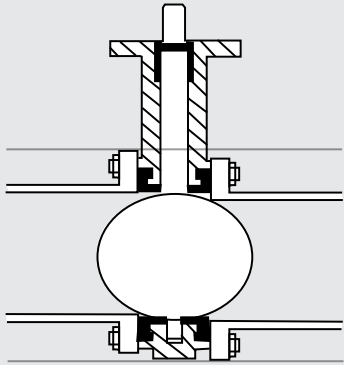
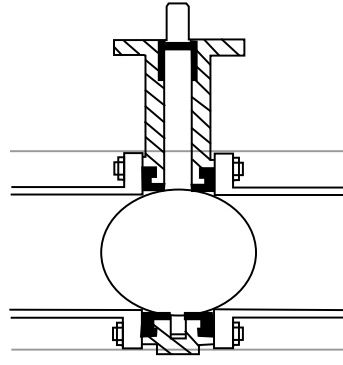

Never complete the welding process (after tacking) with the valve between pipe flanges. This causes severe seat damage due to heat transfer.

4.2 Installation of Bray PTFE Seated Butterfly Valves in Plastic Flanges.

- 4.2.1 Bray recommends the following guidelines when PTFE Seated Valves are installed between plastic flanges:
 - 4.2.1.1 The valve body should be coated with epoxy, not nylon. The extra thickness of the nylon coating slightly reduces the seat compression, and every advantage to maximize seat compression should be taken with plastic flanges.
 - 4.2.1.2 The plastic flange can be either one piece construction, or two piece construction comprised of a stub end and a backup ring.
 - 4.2.1.3 The plastic flange style can be butt-weld, socket or slip-on, but butt-weld and socket are preferred.
 - 4.2.1.4 The plastic flange face must be flat. Concave and convex flange faces are not acceptable. This includes flange faces that were originally flat but later distorted into a concave shape by over tightening the flange bolts.
 - 4.2.1.5 The plastic flange face surface may have grooves or serrations, provided the grooves do not exceed .100" (2.54 mm) in width or .020" (.508 mm) in depth. If the grooves are less than .100" (2.54 mm) in width, the groove depth must not exceed the width. However, fine concentric or "phonograph record" grooves are acceptable regardless of the groove depth.

- 4.2.1.6 Flange gaskets must not be used with PTFE seats, since they create an uncontrolled over compression that can buckle the PTFE and damage the seat. If a damaged face, a flange gasket can appear to cure the leak to atmosphere, while simultaneously damaging the PTFE seat and creating a second leak across the disc or up the stem hole. Leaks across the plastic flange must be cured without the use of gaskets, by proper selection and installation of the flange.
- 4.2.1.7 The bolts holding plastic flanges should be installed in strict conformance to the recommended practices of the plastic flange manufacturer. This usually involves aligning the flanges accurately, using lubricated bolts, and tightening the bolts in the proper sequence and to the specified torque. Uniform stress across the flange prevents leakage.

5.0 MAINTENANCE AND REPAIR



No valve maintenance, including removal of manual or power actuators, should be performed until the piping system is completely depressurized.

- 5.1 The many Bray features minimize wear and maintenance requirements. No routine lubrication is required. **All components - stem, disc, seat, bushing, stem seal, etc., are field replaceable, no adjustment is required.** If components require replacement, the valve may be removed from the line by placing the disc in the near closed position, then supporting the valve and removing the flange bolts.

This page intentionally blank

APPENDIX - DISASSEMBLY/ASSEMBLY INSTRUCTIONS

6.0 Appendix A - Series 20/21 Resilient Seated Butterfly Valves

6.1 Disassembly

- 6.1.1 Remove handle, gear operator or power actuator from actuator mounting flange.
- 6.1.2 Remove the body bolts and pull the lower body half away from the seat.
- 6.1.3 Pull the seat and disc stem from the upper body half.
- 6.1.4 Remove bushing and seal from the upper body.
- 6.1.5 Push the seat into an oval shape and remove the disc stem by withdrawing the short stem end first.

6.2 Assembly

- 6.2.1 Push the long stem end of the disc into the seat.
- 6.2.2 Then push the seat over the disc's short stem.
- 6.2.3 Place the disc stem and seat into the upper body half.
- 6.2.4 Align the lower body with the upper body and position lower body in the seat.

NOTICE

The body halves have a matching casting node on one side only to ensure correct assembly of body halves.

- 6.2.5 Replace the body bolts and tighten.
- 6.2.6 Install the stem seal, then the stem bushing.
Note: It is recommended that the stem bushing be coated with a light amount of silicone grease before installation in the valve body. This coating of silicone grease will assist in keeping the stem bushing in the valve body until an actuator is mounted on the valve.
- 6.2.7 Replace handle, manual gear operator or power actuator on the actuator mounting flange.

BRAY RESILIENT SEATED BUTTERFLY VALVES

Installation, Operation and Maintenance Manual



Series 20/21 - Resilient Seated Butterfly Valves

- 1 Body (S20 Wafer Style Shown)
- 2 Seat
- 3 Disc Stem
- 4 Stem Seal
- 5 Stem Bushing
- 6 Body Bolt

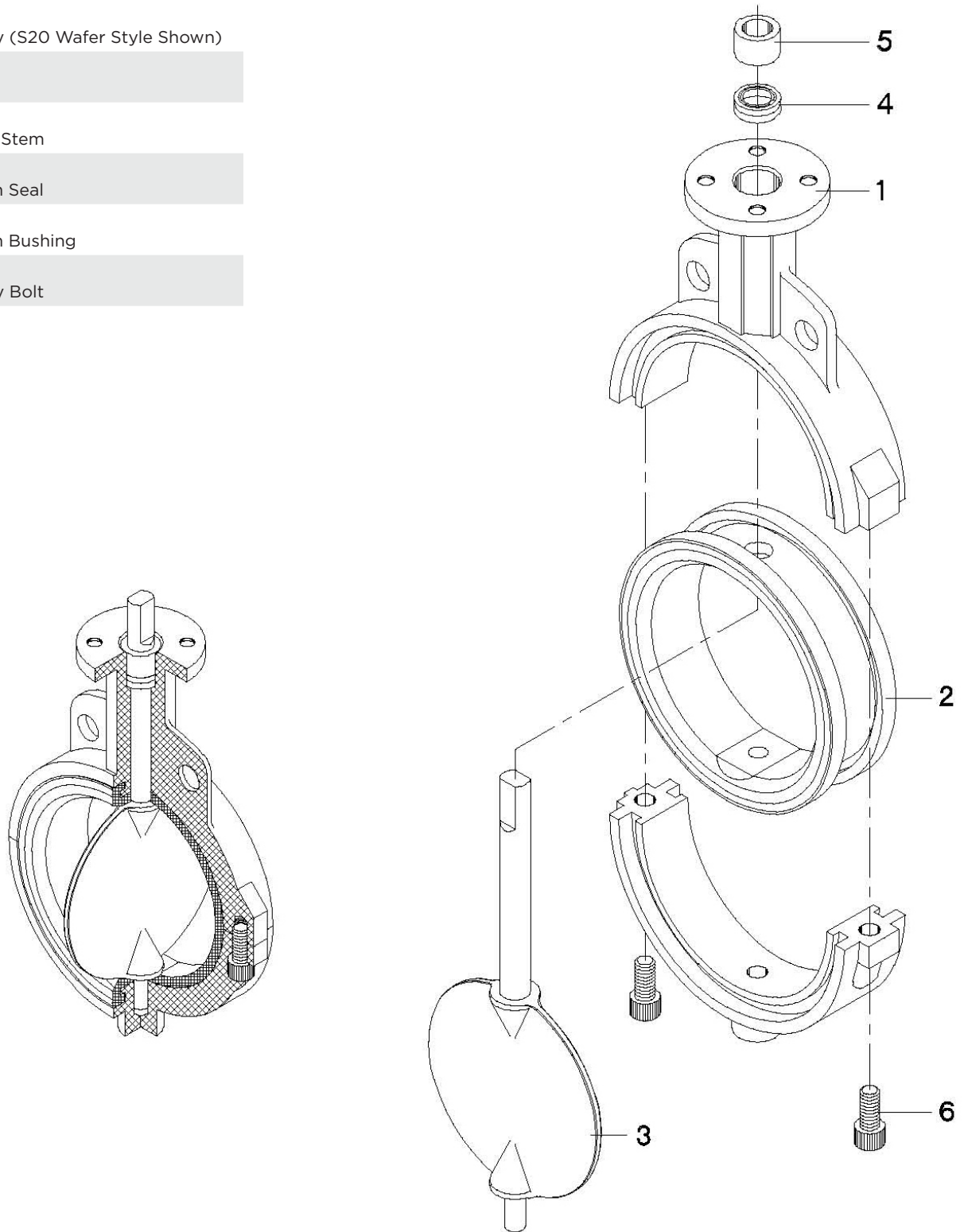

7.0 Appendix B - Series 22/23 Resilient Seated Butterfly Valves

7.1 Disassembly

- 7.1.1 Remove the handle, gear operator, or power actuator from actuator mounting flange.
- 7.1.2 Remove the "Spirolox"® retaining ring and the two C-ring stem retainers from the stem hole.
- 7.1.3 Then remove the stem, bushing and seal.
- 7.1.4 Remove the disc from the seat, protecting the disc edge at all times.
- 7.1.5 Remove the seat energizer from the stems and seat.
- 7.1.6 Remove the lower and upper stems from the disc or remove the lower stem if the upper stem is connected to the disc.
- 7.1.7 Compress the seat just enough to allow the disc to be removed along with the seal capsules.
- 7.1.8 Remove the retainer bushing and upper stem seal.

7.2 Assembly

- 7.2.1 Install the stem bearings in upper and lower body halves.
- 7.2.2 Place the body seal strip on the lower body half, overlapping the body width by approximately 0.19" on both sides.
- 7.2.3 Press the seat to make the I.D. elliptical, then insert the shaft seals and place the disc into the seat. Rotate the disc hubs into alignment with the seat.
- 7.2.4 Insert the upper and lower stems.
- 7.2.5 Slip one seat energizer strip onto the lower portion of the upper shaft.
- 7.2.6 Insert the upper shaft with the pre-installed seat energizer strip into the disc/seat sub assembly.
- 7.2.7 Drive the upper shaft into the disc and slip one seat energizer strip onto the lower shaft.
- 7.2.8 Rotate the disc into the open position and insert the disc/seat/stems/energizer sub assembly into the upper body half.
- 7.2.9 Place the lower body half over the seat, and ensure that both body halves are properly aligned (identified by cast-on markings).
- 7.2.10 Attach and tighten the body fasteners.

BRAY RESILIENT SEATED BUTTERFLY VALVES

Installation, Operation and Maintenance Manual



Series 22/23 - Resilient Seated Butterfly Valves

- 1 Body
- 2 Disc
- 3 Seat
- 4 Upper Stem
- 5 Lower Stem
- 6 Bushing
- 7 Upper Stem Seal
- 8 Seal Capsule
- 9 Bearing
- 10 Seat Energizer
- 11 Cap Screw
- 12 Retainer
- 13 Body Seal
- 14 ID Tag

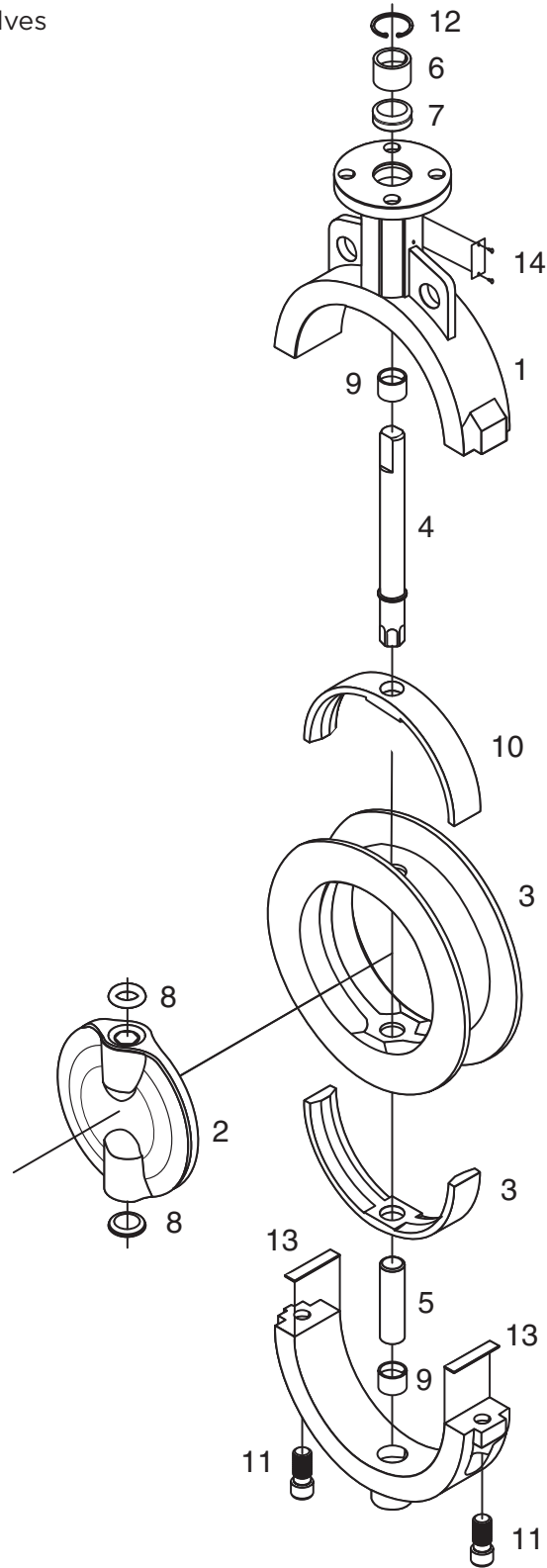

8.0 Appendix C - Series 30/31 Resilient Seated Butterfly Valves

8.1 Disassembly

- 8.1.1 Remove the handle, gear operator, or power actuator from actuator mounting flange.
- 8.1.2 Remove the “Spirolox”® retaining ring and the two C-ring stem retainers from the stem hole.
- 8.1.3 Then remove the stem, bushing and seal.
- 8.1.4 Remove the disc from the seat, protecting the disc edge at all times.
- 8.1.5 Push the seat into an oval shape, and then remove the seat from the body.

8.2 Assembly

- 8.2.1 Push the valve seat into an oval and push it into the body with seat stem holes aligned to body stem holes.

NOTICE

When installing the seat the larger hole should be on top and the smaller hole should be on bottom.

- 8.2.2 Insert stem seal and bushing.
- 8.2.3 Push stem into the stem hole of the body until the bottom of the stem is flush with the inner top edge of the seat.
- 8.2.4 Install a light coating of silicone or grease on the I.D. of seat. Insert the disc into the seat by lining up the disc holes with the stem holes of the seat.
Note: The broached double “D” flats in the disc must be toward the bottom of the valve body.
- 8.2.5 With a downward pressure and rotating the stem back and forth, push the stem until the stem touches the bottom of the body stem hole.
- 8.2.6 Make certain that when pushing the stem through the disc bottom, the broached flats of stem and disc are aligned.
- 8.2.7 Replace the stem bushing and two stem retainers, then replace the “Spirolox”® retaining ring back into position.
- 8.2.8 Replace handle, manual gear operator or power actuator on the actuator mounting flange.

BRAY RESILIENT SEATED BUTTERFLY VALVES

Installation, Operation and Maintenance Manual



Series 30/31 - Resilient Seated Butterfly Valves

- 1 Body (S30 Wafer Style Shown)
- 2 Seat
- 3 Disc
- 4 Stem
- 5 Stem Seal
- 6 Stem Bushing
- 7 Stem Retainer
- 8 Thrust Washer
- 9 Retainer Ring

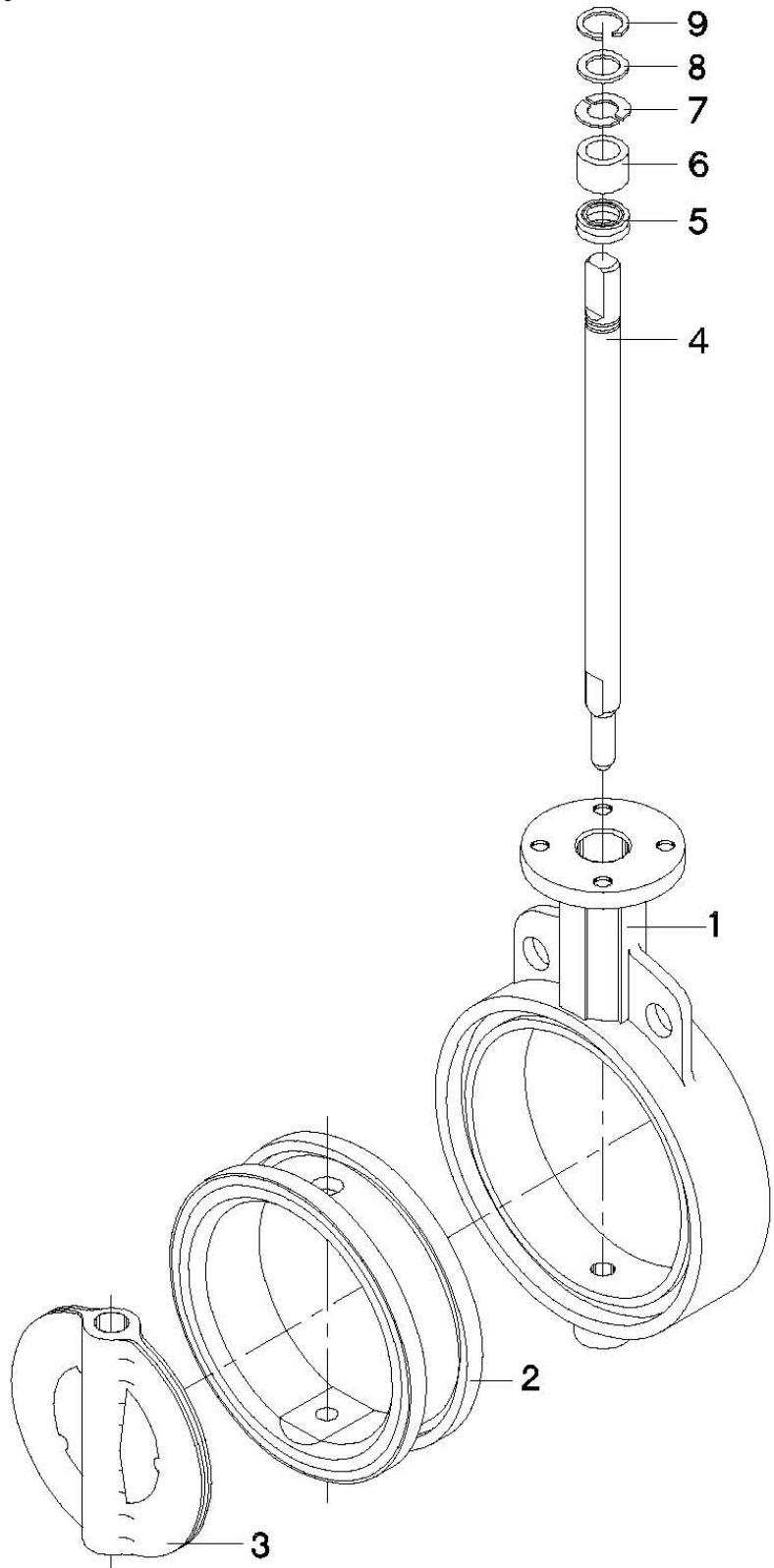
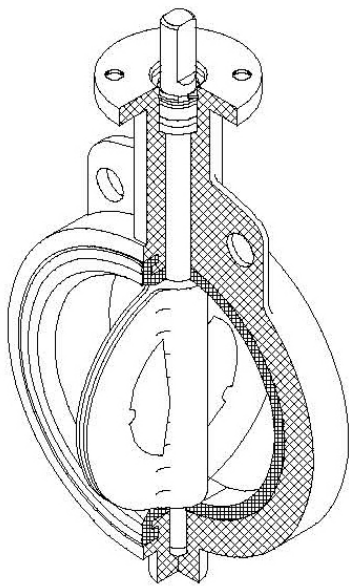

9.0 Appendix D - Series 3A/3AH Resilient Seated Butterfly Valves

9.1 Disassembly

- 9.1.1 Remove the handle, gear operator, or power actuator from actuator mounting flange.
- 9.1.2 Remove the “Spirolox”® retaining ring and the two C-ring stem retainers from the stem hole.
- 9.1.3 Then remove the stem, bushing and seal.
- 9.1.4 Remove the disc from the seat, protecting the disc edge at all times.

Note: The seat is bonded to the body and is not easily field replaceable. Please contact your local Bray representative for seat replacement.

9.2 Assembly

- 9.2.1 Insert stem seal and bushing.
- 9.2.2 Push stem into the stem hole of the body until the bottom of the stem is flush with the inner top edge of the seat.
- 9.2.3 Install a light coating of silicone or grease on the I.D. of seat. Insert the disc into the seat by lining up the disc holes with the stem holes of the seat. Note: The broached double “D” flats in the disc must be toward the bottom of the valve body.
- 9.2.4 With a downward pressure and rotating the stem back and forth, push the stem until the stem touches the bottom of the body stem hole.
- 9.2.5 Make certain that when pushing the stem through the disc bottom, the broached flats of stem and disc are aligned.
- 9.2.6 Replace the stem bushing and two stem retainers, then replace the “Spirolox”® retaining ring back into position.
- 9.2.7 Replace handle, manual gear operator or power actuator on the actuator mounting flange.

BRAY RESILIENT SEATED BUTTERFLY VALVES

Installation, Operation and Maintenance Manual



Series 3A/3AH - Resilient Seated Butterfly Valves

- 1 Body
- 2 Seat
- 3 Disc
- 4 Stem
- 5 Stem Seal
- 6 Stem Bushing
- 7 Stem Retainer
- 8 Thrust Washer
- 9 Retaining Ring

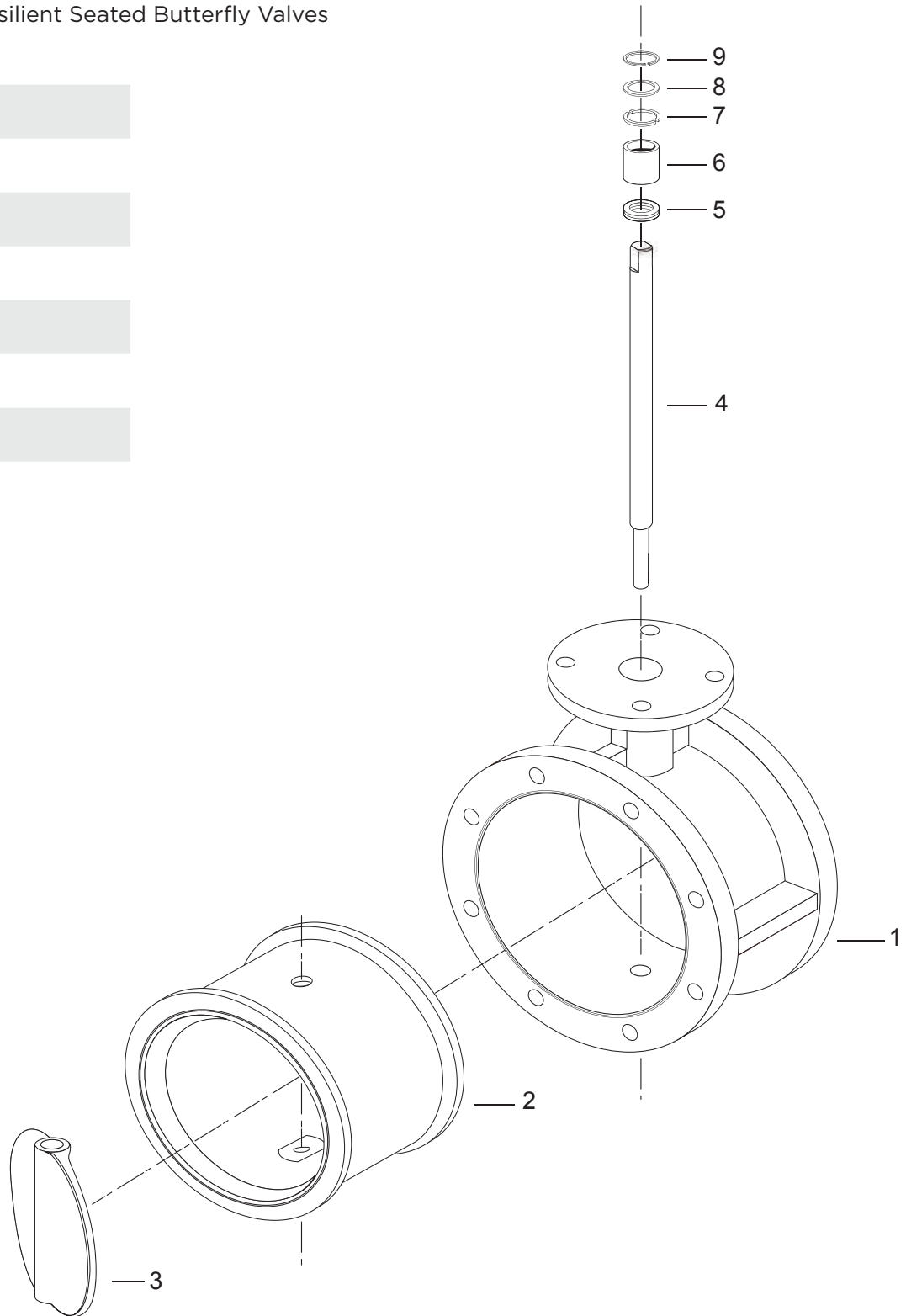

10.0 Appendix E - Series 31H Resilient Seated Butterfly Valves

10.1 Disassembly

- 10.1.1 Remove the handle, gear operator, or power actuator from actuator mounting flange.
- 10.1.2 Remove the “Spirolox”® retaining ring and the two C-ring stem retainers from the stem hole.
- 10.1.3 Then remove the stem, bushing and seal.
- 10.1.4 Remove the disc from the seat, protecting the disc edge at all times.

Note: Valve is provided with the seat bonded to the body and therefore is not easily field replaceable. Please contact your local Bray representative for seat replacement.

10.2 Assembly

- 10.2.1 Insert stem seal and bushing.
- 10.2.2 Push stem into the stem hole of the body until the bottom of the stem is flush with the inner top edge of the seat.
- 10.2.3 Install a light coating of silicone or grease on the I.D. of seat. Insert the disc into the seat by lining up the disc holes with the stem holes of the seat.
Note: The broached double “D” flats in the disc must be toward the bottom of the valve body.
- 10.2.4 With a downward pressure and rotating the stem back and forth, push the stem until the stem touches the bottom of the body stem hole.
- 10.2.5 Make certain that when pushing the stem through the disc bottom, the broached flats of stem and disc are aligned.
- 10.2.6 Replace the stem bushing and two stem retainers, then replace the “Spirolox”® retaining ring back into position.
- 10.2.7 Replace handle, manual gear operator or power actuator on the actuator mounting flange.

BRAY RESILIENT SEATED BUTTERFLY VALVES

Installation, Operation and Maintenance Manual



Series 31H - Resilient Seated Butterfly Valves

1 Body S30 Wafer Style Shown)

2 Seat

3 Disc

4 Stem

5 Stem Seal

6 Stem Bushing

7 Stem Retainer

8 Thrust Washer

9 Retaining Ring

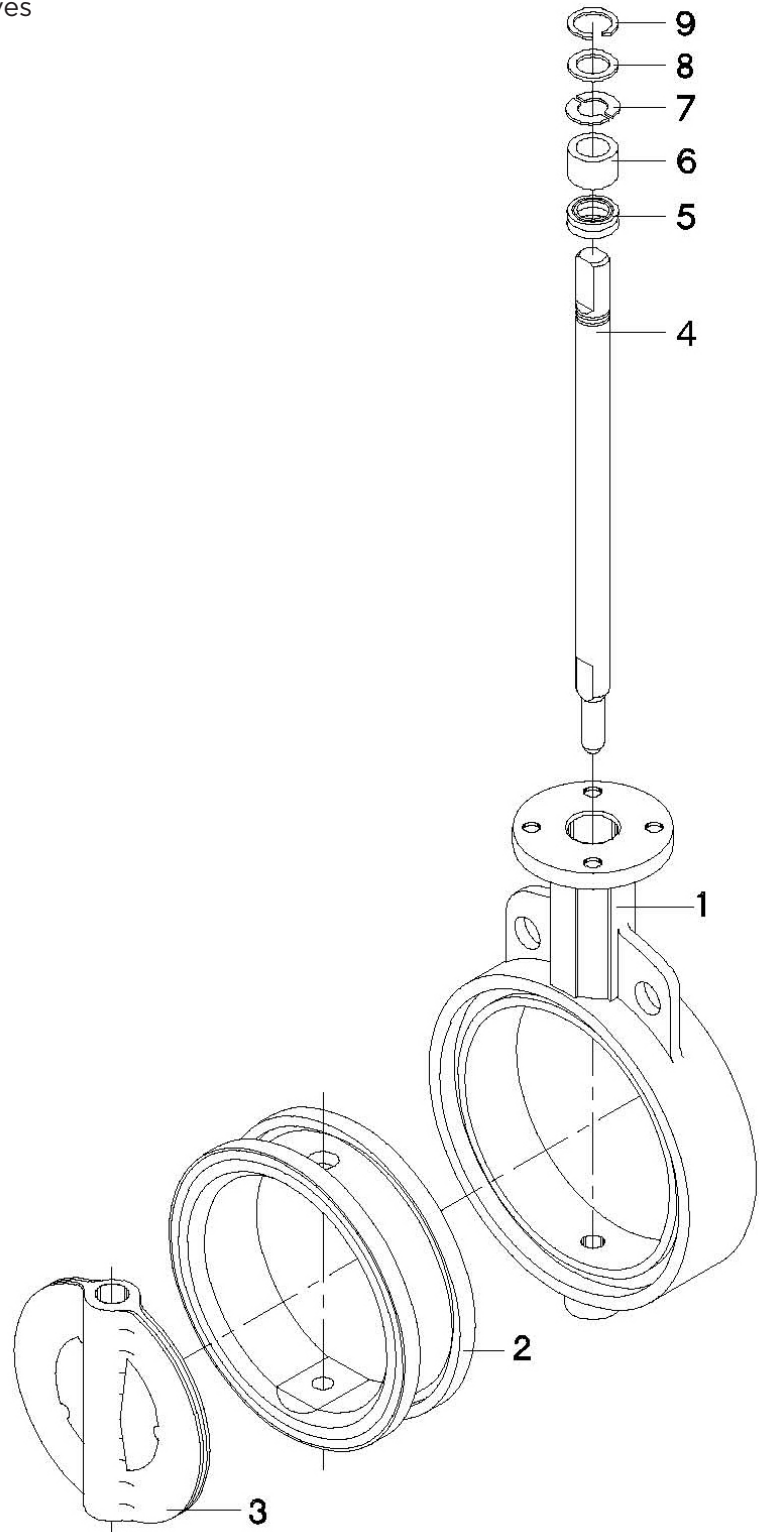

11.0 Appendix F - Series 31U Resilient Seated Butterfly Valves

11.1 Disassembly

- 11.1.1 Remove the handle, gear operator, or power actuator from actuator mounting flange.
- 11.1.2 Remove the "Spirolox"® retaining ring and the two C-ring stem retainers from the stem hole.
- 11.1.3 Then remove the top stem bushing and seal, upper stem and retaining rod.
- 11.1.4 Remove the disc from the seat, protecting the disc edge at all times.
- 11.1.5 The upper and lower stem bearings will remain in the valve behind the seat.

Note: The seat is bonded to the body and is not easily field replaceable. Please contact your local Bray representative for seat replacement.

11.2 Assembly

- 11.2.1 Install a light coating of silicone or grease on the I.D. of seat.
- 11.2.2 Insert the lower stem inside the disc before inserting the disc into the seat.
- 11.2.3 Insert the disc into the seat by lining up the disc holes with the stem holes of the seat.
- 11.2.4 Line up the disc using a T-Bar (Allan key style)
- 11.2.5 With a downward pressure and rotating the T-Bar back and forth, push the lower stem until the lower stem touches the bottom of the body stem hole recess.
Note: The broached double "D" flats in the disc must be toward the bottom of the valve body.
- 11.2.6 Make certain that when pushing the stem through the disc bottom, the broached flats of stem and disc are aligned.
- 11.2.7 Insert the spacer bar and upper stem into the disc and valve.
- 11.2.8 Replace the top stem bushing and seal and two stem retainers.
- 11.2.9 Then replace the two "C" ring stem retainers and the "Spirolox"® retaining ring back into position in the top stem hole.
Note: It is recommended that a torque and seat test be done to confirm all is in order with the maintenance of the valve.
- 11.2.10 Replace the handle, manual gear operator or power actuator on the actuator mounting flange.

BRAY RESILIENT SEATED BUTTERFLY VALVES

Installation, Operation and Maintenance Manual



Series 31U - Resilient Seated Butterfly Valves

- 1 Body
- 2 Disc
- 3 Upper Stem
- 4 Lower Stem
- 5 Seat
- 6 Bearing
- 7 Stem Seal
- 8 Stem Bushing
- 9 Stem Retainer Washers
- 10 Upper Thrust Washer
- 11 Retaining ring
- 12 Lower Thust Washer
- 13 Spacer
- 14 Seal Plug

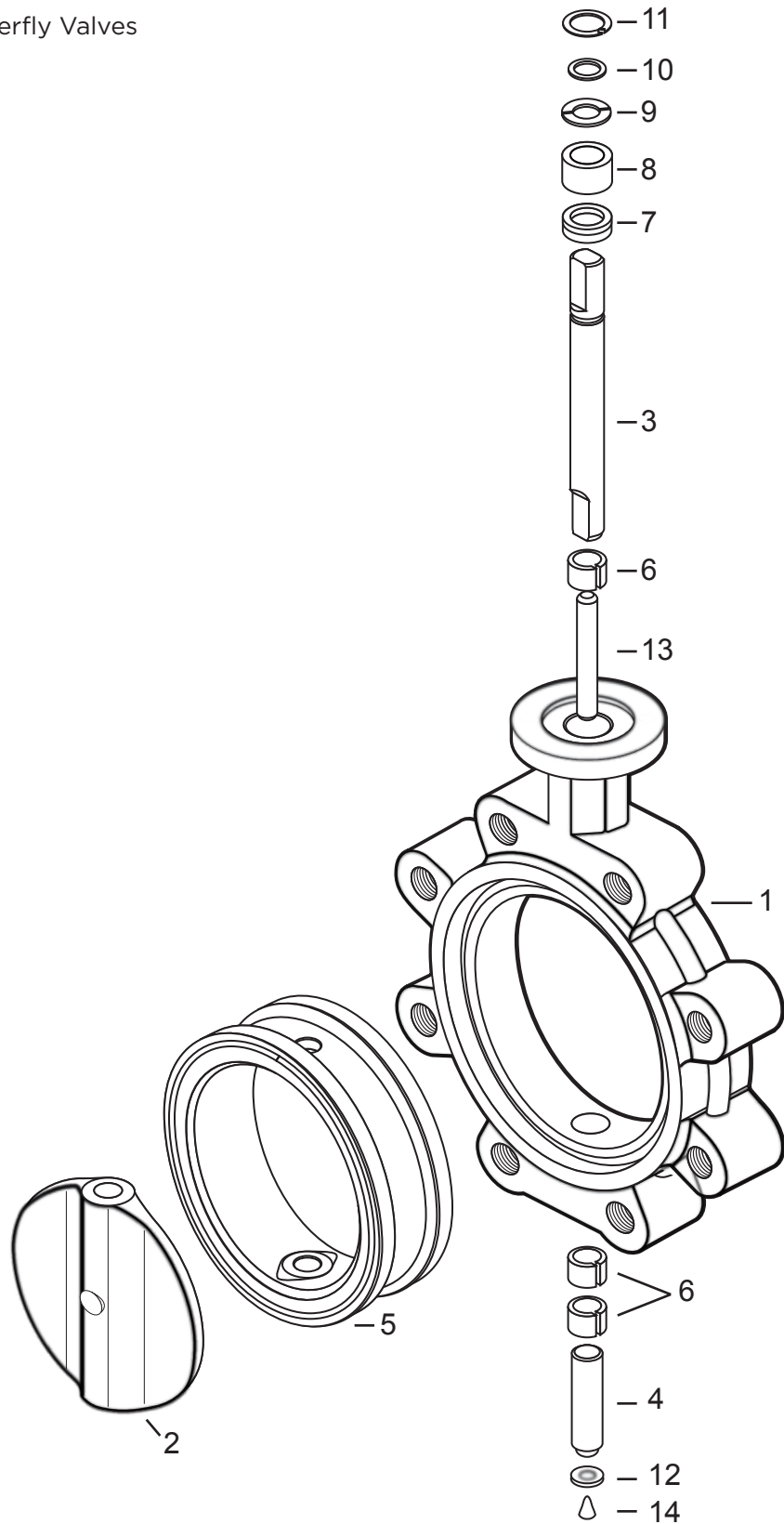

12.0 Appendix G - Series 32/33 Resilient Seated Butterfly Valves

12.1 Disassembly

- 12.1.1 Remove the gear operator or power actuator from the actuator mounting flange.
- 12.1.2 Secure the valve in a horizontal position with the taper-pin nuts facing upward.



CAUTION

Prior to removal of the valve stem the valve disc must be secured and supported to insure it does not drop out of the valve body once the stem is removed. Lay the valve down with two wood blocks located under the disc at the 6 o'clock and 12 o'clock positions making sure the blocks are in close contact with the disc but not supporting the valve.

- 12.1.4 Remove the packing gland by removing the retaining screws and sliding the gland off the top of the stem.
- 12.1.5 Remove bottom plate and thrust bearing to expose bottom of stem.
- 12.1.6 Remove nuts and washers from ends of taper pins and drive taper pins out of the disc. Avoid damaging the disc coating or surface when removing taper-pins.
- 12.1.7 Once taper-pins are removed, drive the stem, bushing, and packing out of the valve body through the top.
- 12.1.8 Remove the disc from the seat, protecting disc edge at all times.
- 12.1.9 Push the seat into an oval shape, and then remove the seat from the body.

12.2 Assembly

- 12.2.1 Replace bottom thrust bearing and plate.
- 12.2.2 Push the seat into an oval and push it into the body with seat stem holes aligned to body stem holes.
- 12.2.3 De-bur taper-pin grooves in the stem.
- 12.2.4 Push stem into stem hole of body until the bottom of the stem is flush with the inner top edge of the seat.
Note: The end of the stem containing the keyway must be toward the top of the valve body.
- 12.2.5 Install a light coating of silicone or grease on the I.D. of the seat.
- 12.2.6 Insert the disc into the seat by lining up the disc hole with the upper stem hole of the seat.
- 12.2.7 With a downward pressure and rotating the stem back and forth, push the stem until the stem touches the bottom of the body stem hole.
Note: Make certain that when pushing the stem to the bottom of the body, the taper-pin grooves in the stem line up with the holes in the disc face.
- 12.2.8 Tap the taper-pins into their holes from the large side of the hole, making sure the pins fit tightly in the hole and allow no movement of the stem in the disc.
Note: Ensure that the taper-pin o-rings are in place before completing valve assembly.
- 12.2.9 Replace the washers and nuts on the ends of the taper-pins.
- 12.2.10 Replace bushing, packing, and packing gland, and then tighten the retaining screws snugly.
- 12.2.11 Replace manual gear operator or power actuator on the actuator mounting flange.

BRAY RESILIENT SEATED BUTTERFLY VALVES

Installation, Operation and Maintenance Manual



Series 32/33 - Resilient Seated Butterfly Valves

- 1 Body
- 2 Disc
- 3 Stem
- 4 Seat
- 5 Stem Packing
- 6 Stem Bearing
- 7 Taper Pin
- 8 Washer
- 9 Nut
- 10 O-Ring
- 11 Thrust Bearing
- 12 Bottom Plate
- 13 Bottom Plate Gasket
- 14 Bolt-Hex Head
- 15 Key
- 16 Stem Retainer
- 17 Ca[Screw
- 18 ID Tag
- 19 POP Rivet

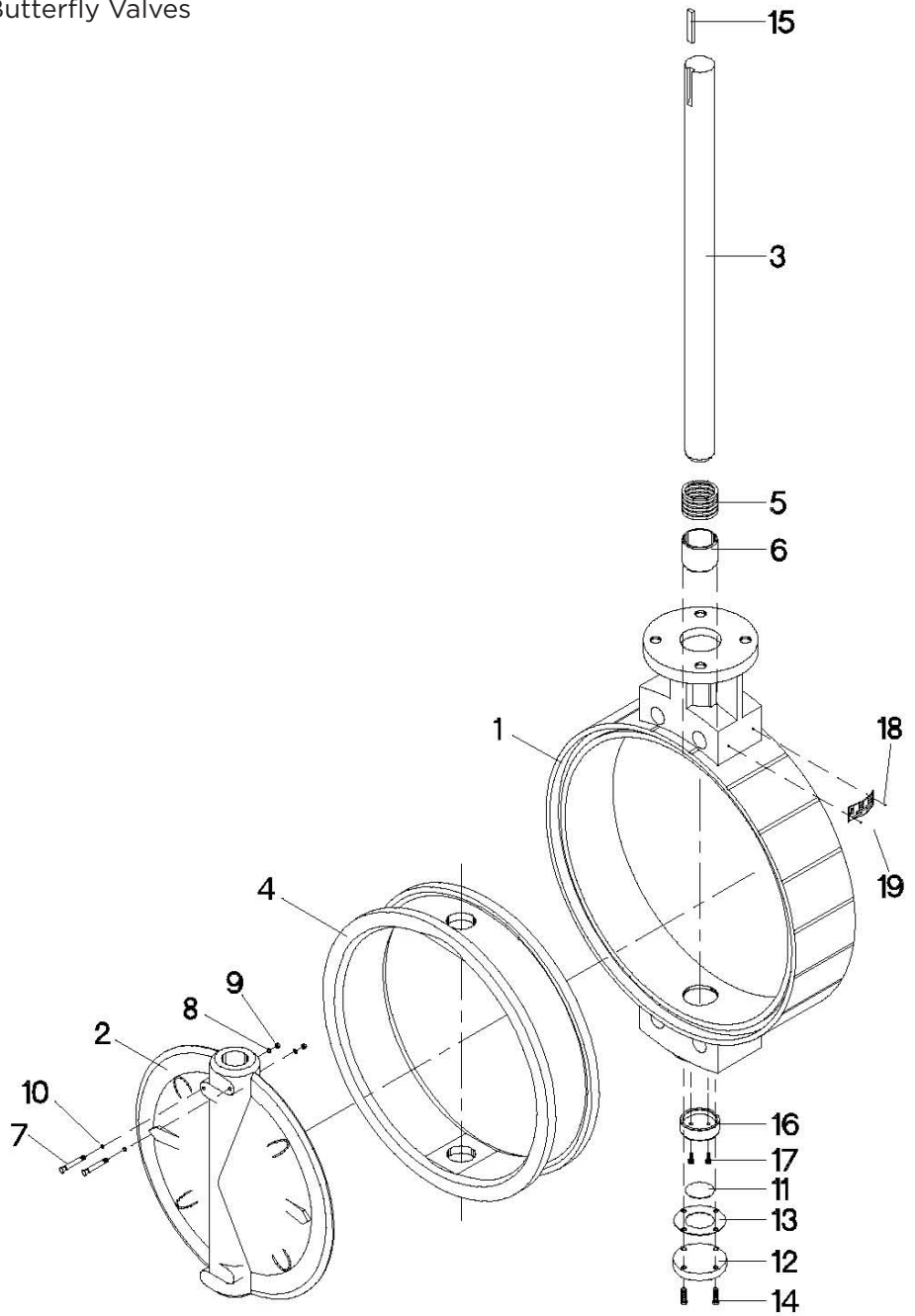

13.0 Appendix H - Series 35/36 Resilient Seated Butterfly Valves (Taper Pin Disc/Stem Connection)

13.1 Disassembly

- 13.1.1 Remove the gear operator or power actuator from the actuator mounting flange.
- 13.1.2 Secure the valve in a horizontal position with the taper-pin nuts facing upward.



Prior to removal of the valve stem the valve disc must be secured and supported to insure it does not drop out of the valve body once the stem is removed. Lay the valve down with two wood blocks located under the disc at the 6 o'clock and 12 o'clock positions making sure the blocks are in close contact with the disc but not supporting the valve.

- 13.1.3 Remove the packing gland by removing the retaining screws and sliding the gland off the top of the stem.
- 13.1.4 Remove bottom plate and thrust bearing to expose bottom of stem.
- 13.1.5 Remove nuts and washers from ends of taper pins and drive taper pins out of the disc. Avoid damaging the disc coating or surface when removing taper-pins.
- 13.1.6 Once taper-pins are removed, drive the stem, bushing, and packing out of the valve body through the top.
- 13.1.7 Remove the disc from the seat, protecting disc edge at all times.
- 13.1.8 Push the seat into an oval shape, and then remove the seat from the body.
Note: Valves 54" and larger are provided with the seat bonded to the body and therefore is not easily field replaceable. Please contact your local Bray representative for seat replacement.

13.2 Assembly

- 13.2.1 Replace bottom thrust bearing and plate.
- 13.2.2 Push the seat into an oval and push it into the body with seat stem holes aligned to body stem holes.
Note: Valves 54" and larger are provided with the seat bonded to the body and therefore is not easily field replaceable. Please contact your local Bray representative for seat replacement.
- 13.2.3 De-bur taper-pin grooves in the stem.
- 13.2.4 Push stem into stem hole of body until the bottom of the stem is flush with the inner top edge of the seat.
Note: The end of the stem containing the keyway must be toward the top of the valve body.
- 13.2.5 Install a light coating of silicone or grease on the I.D. of the seat.
- 13.2.6 Insert the disc into the seat by lining up the disc hole with the upper stem hole of the seat.
- 13.2.7 With a downward pressure and rotating the stem back and forth, push the stem until the stem touches the bottom of the body stem hole.
Note: Make certain that when pushing the stem to the bottom of the body, the taper-pin grooves in the stem line up with the holes in the disc face.
- 13.2.8 Tap the taper-pins into their holes from the large side of the hole, making sure the pins fit tightly in the hole and allow no movement of the stem in the disc.
Note: Ensure that the taper-pin o-rings are in place before completing valve assembly.
- 13.2.9 Replace the washers and nuts on the ends of the taper-pins.
- 13.2.10 Replace bushing, packing, and packing gland, and then tighten the retaining screws snugly.
- 13.2.11 Replace manual gear operator or power actuator on the actuator mounting flange.

BRAY RESILIENT SEATED BUTTERFLY VALVES

Installation, Operation and Maintenance Manual



Series 35/36 - Resilient Seated Butterfly Valves (Taper Pin Disc/Stem Connection)

- 1 Body
- 2 Disc
- 3 Stem
- 4 Seat
- 5 Stem Packing
- 6 Stem Bearing
- 7 Taper Pin
- 8 Washer
- 9 Nut
- 10 O-Ring
- 11 Thrust Bearing
- 12 Bottom Plate
- 13 Bottom Plate Gasket
- 14 Bolt-Hex Head
- 15 Key
- 16 Stem Retainer
- 17 Cap Screw
- 18 Packing Gland
- 19 Bolt-Hex Head
- 20 ID Tag
- 21 Pop Rivet

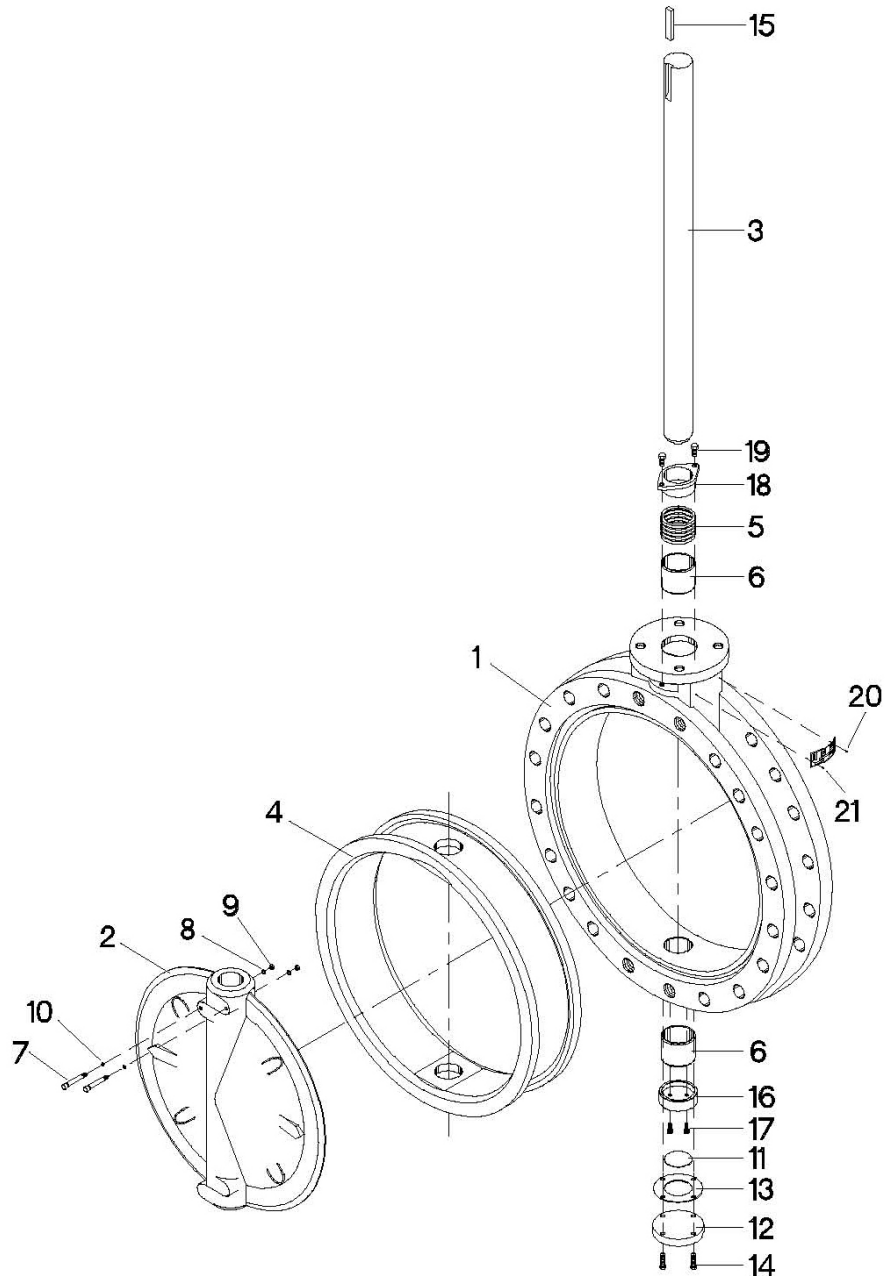

14.0 Appendix I - Series 35/36 Resilient Seated Butterfly Valves (Internal Spine or Keyed Disc/ Stem Connection)

14.1 Disassembly

14.1.1 Remove the gear operator or power actuator from the actuator mounting flange.

14.1.2 Secure the valve in a horizontal position.



Prior to removal of the valve stems the valve disc must be secured and supported to insure it does not drop out of the valve body once the stems are removed. Lay the valve down with two wood blocks located under the disc at the 6 o'clock and 12 o'clock positions making sure the blocks are in close contact with the disc but not supporting the valve.

- 14.1.3 Removal of the lower valve stem:
- > Remove the bottom plate screws, bottom plate, bottom plate gasket and thrust bearing.
 - > Remove the locking nut from the tie bolt.
 - > Remove the stem retainer.
 - > Secure a hoist to the lower stem (end is imperial threaded).
 - > Then use the hoist to remove the lower stem from the valve body.
 - > Remove the stem bearing.

- 14.1.4 Removal of the upper valve stem:
- > Remove the packing gland by removing the retaining screws and sliding the gland off the top of the stem.
 - > Secure a hoist to the upper stem (end is imperial threaded).
 - > Then use the hoist to remove the upper stem including the tie bolt from the valve body.

- 14.1.5 Removal of the valve disc:
- > Remove the wood blocks noted above from below the disc.
 - > Using a rubber hammer, pound one area of the disc (ex. 12 o'clock position) repeatedly until the disc clears the face of the valve body.

- 14.1.6 Removal of packing and bearings:
- > Remove the stem packing.
 - > Use a slotted screwdriver to carefully remove the upper and lower stem bearings.

- 14.1.7 Removal of the valve seat:
- Note: Valves 54" and larger are provided with the seat bonded to the body and therefore is not easily field replaceable. Please contact your local Bray representative for seat replacement.**



Set the valve body in an upright position and secure it in a floor vice capable of handling the weight of the valve body and seat.

Note: Be sure to not clamp the seat in the vice.

- 14.1.8 Insert a slotted screwdriver into the space between the body and the seat on the face of the valve at the 12 o'clock position.
- 14.1.9 Carefully leverage the seat away from the body.
- 14.1.10 Push the seat into an oval shape and remove the seat from the body.

14.0 Appendix I - Series 35/36 Resilient Seated Butterfly Valves (Internal Spine or Keyed Disc/ Stem Connection)

14.2 Assembly

14.2.1 Installation of the valve seat:

Note: Valves 54" and larger are provided with the seat bonded to the body and therefore is not easily field replaceable. Please contact your local Bray representative for seat replacement.



Set the valve body in an upright position and secure it in a floor vice capable of handling the weight of the valve body and seat.

Note: Be sure to not clamp the seat in the vice.

- > Check to assure the interior surface of the valve body is clean.
- > Install a light coating of silicone lubricant on the interior surface of the valve body.
- > Push the seat into an oval and push it into the body with seat stem holes aligned to the body stem holes.

14.2.2 Installation of the valve disc:

Note: Before installing the disc, check to assure the upper and lower stems are matched to the upper and lower stem holes in the disc.

- > With the valve still in the vice in a vertical position, hoist the upper stem with the splined end or the double keyed end pointing upward.
- > Push the upper stem into the stem hole of the upper body until the bottom of the stem exceeds the upper stem hole of the seat by 20-50 mm.
- > Apply a light coating of silicone or grease on the I.D. of the seat.
- > Insert the disc into the seat with the splined end or the double keyed end up.
- > Push the disc into the seat while inserting the upper stem into the upper stem hole in the disc.
- > Adjust the disc to assure the lower stem hole of the disc is properly aligned with the lower body stem hole.

14.2.3 Installation of the lower stem:

- > Close the valve so that the disc is inside the edge of the seat.
- > Carefully place the valve in a horizontal position assuring that there is no damage to the body and disc coatings and disc edge.
- > Insert the stem bearing into the bottom stem hole of the body.
- > Insert the lower stem into the body and disc.

Note: The cone-shaped end of the lower stem should be toward the center of the disc.

14.2.4 Installation of the upper stem:



Hoist the valve to an angle and secure it (be careful not to go too high so the lower stem does not drop out).

- > Remove the upper stem from the valve.
- > Screw the tie bolt with lock nut to the splined or the double keyed end of the upper stem, tighten the lock nut and insert the upper stem into the valve with the tie bolt end first.

Note: The tie bolt will go through the disc and reach to the bottom of the valve.

Note: During this step, the keyway of the upper stem should be vertical to the front face of the valve.

14.2.5 Installation of packing and bearings (upper valve stem):

- > Insert the stem bearing into the top hole of the body followed by the stem packing and packing gland follower.
- > Use two hexagon bolts to fasten the packing gland.

14.2.6 Installation of packing and bearings (lower valve stem):

- > Insert the stem retainer into the bottom hole of the body using a nut to fasten it.
- > Install the locking nut on the tie bolt.
- > Install the thrust bearing, bottom plate gasket and bottom plate follower.
- > Use four hexagon bolts to fasten the bottom plate tightly.

BRAY RESILIENT SEATED BUTTERFLY VALVES

Installation, Operation and Maintenance Manual



Series 35/36 - Resilient Seated Butterfly Valves (Internal Spline Valve)

- 1 Body
- 2 Disc
- 3 Upper Stem
- 4 Seat
- 5 Key
- 6 Tie Bolt
- 7 Stem Bearing
- 8 Stem Packing
- 9 Packing Gland Follower
- 10 Packing Gland
- 11 Bolt-Hex Head
- 12 Lower Stem
- 13 Stem Retainer
- 14 Hex Nut
- 15 Thrust Bearing
- 16 Bottom Plate Gasket
- 17 Bottom Plate
- 18 Bolt-Hex Head
- 19 ID Tag
- 20 Pop Rivet

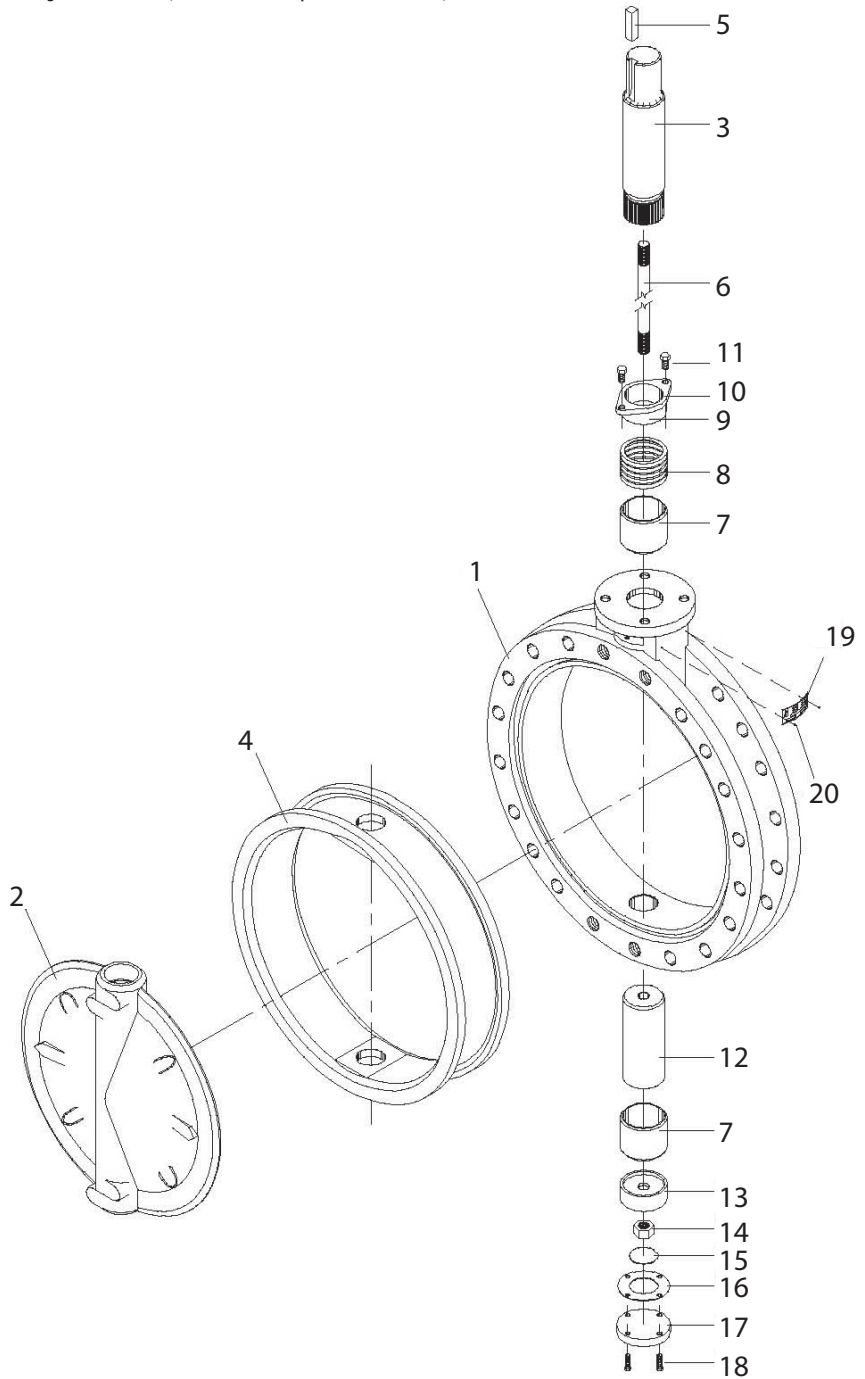

BRAY RESILIENT SEATED BUTTERFLY VALVES

Installation, Operation and Maintenance Manual



Series 35/36 - Resilient Seated Butterfly Valves (Internal Keyed Valve)

- 1 Body
- 2 Disc
- 3 Upper Stem
- 4 Seat
- 5 Key
- 6 Tie Bolt
- 7 Stem Bearing
- 8 Stem Packing
- 9 Packing Gland Follower
- 10 Packing Gland
- 11 Bolt-Hex Head
- 12 Lower Stem
- 13 Stem Retainer
- 14 Hex Nut
- 15 Thrust Bearing
- 16 Bottom Plate Gasket
- 17 Bottom Plate
- 18 Bolt-Hex Head
- 19 ID Tag
- 20 Pop Rivet

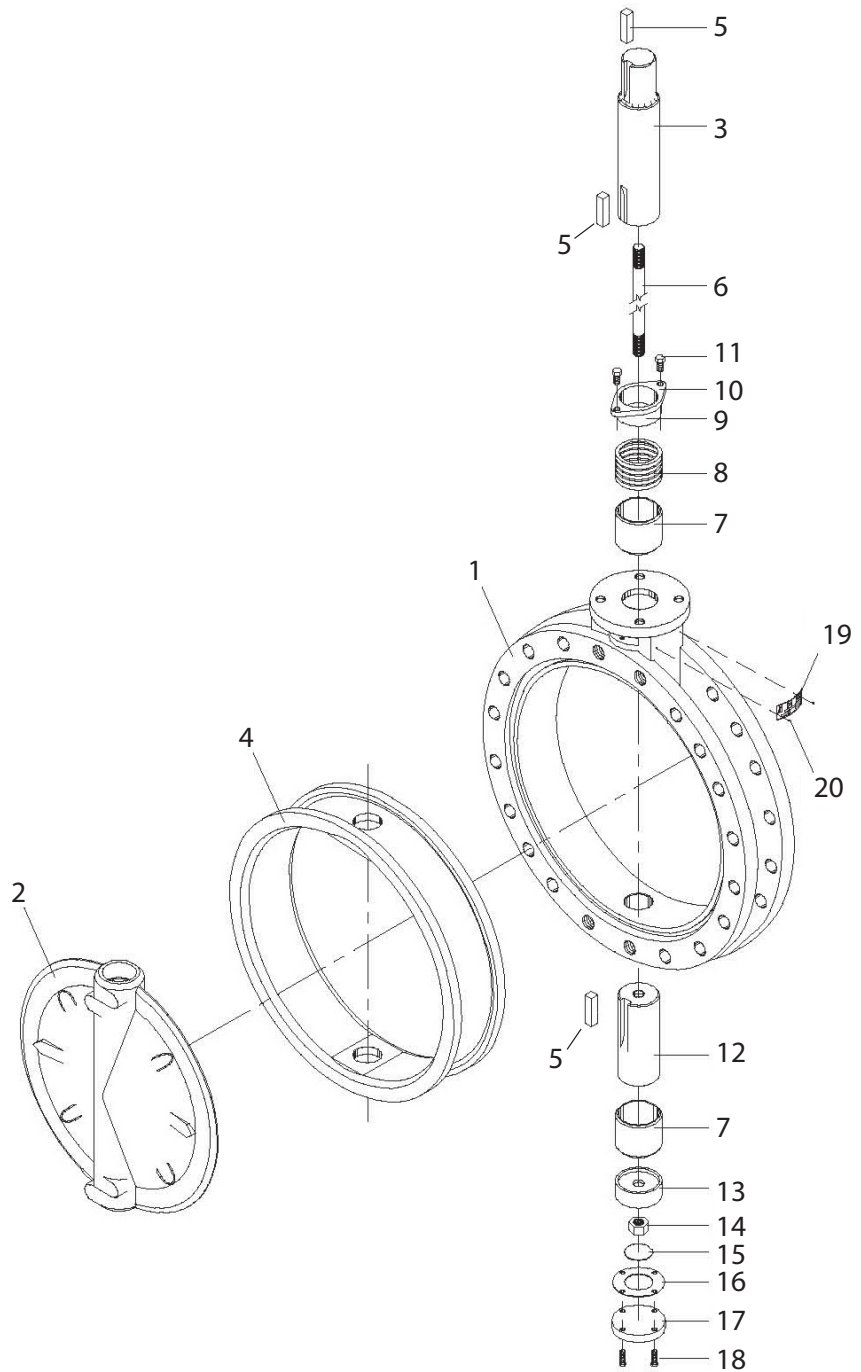

15.0 Appendix J - Series 36H Resilient Seated Butterfly Valves

15.1 Disassembly

- 15.1.1 Remove the gear operator or power actuator from the actuator mounting flange.
- 15.1.2 Secure the valve in a horizontal position with the taper-pin nuts facing upward.



Prior to removal of the valve stem the valve disc must be secured and supported to insure it does not drop out of the valve body once the stem is removed. Lay the valve down with two wood blocks located under the disc at the 6 o'clock and 12 o'clock positions making sure the blocks are in close contact with the disc but not supporting the valve.

- 15.1.3 Remove the packing gland by removing the retaining screws and sliding the gland off the top of the stem.
- 15.1.4 Remove bottom plate and thrust bearing to expose bottom of stem.
- 15.1.5 Remove nuts and washers from ends of taper pins and drive taper pins out of the disc. Avoid damaging the disc coating or surface when removing taper-pins.
- 15.1.6 Once taper-pins are removed, drive the stem, bushing, and packing out of the valve body through the top.
- 15.1.7 Remove the disc from the seat, protecting disc edge at all times.
Note: Valve is provided with the seat bonded to the body and therefore is not easily field replaceable. Please contact your local Bray representative for seat replacement.

15.2 Assembly

- 15.2.1 Replace bottom thrust bearing and plate.
- 15.2.2 De-bur taper-pin grooves in the stem.
- 15.2.3 Push stem into stem hole of body until the bottom of the stem is flush with the inner top edge of the seat.
Note: The end of the stem containing the keyway must be toward the top of the valve body.
- 15.2.4 Install a light coating of silicone or grease on the I.D. of the seat.
- 15.2.5 Insert the disc into the seat by lining up the disc hole with the upper stem hole of the seat.
- 15.2.6 With a downward pressure and rotating the stem back and forth, push the stem until the stem touches the bottom of the body stem hole.
Note: Make certain that when pushing the stem to the bottom of the body, the taper-pin grooves in the stem line up with the holes in the disc face.
- 15.2.7 Tap the taper-pins into their holes from the large side of the hole, making sure the pins fit tightly in the hole and allow no movement of the stem in the disc.
Note: Ensure that the taper-pin o-rings are in place before completing valve assembly.
- 15.2.8 Replace the washers and nuts on the ends of the taper-pins.
- 15.2.9 Replace bushing, packing, and packing gland, and then tighten the retaining screws snugly.
- 15.2.10 Replace manual gear operator or power actuator on the actuator mounting flange.

BRAY RESILIENT SEATED BUTTERFLY VALVES

Installation, Operation and Maintenance Manual



Series 36H - Resilient Seated Butterfly Valves

- 1 Body
- 2 Disc
- 3 Stem
- 4 Seat
- 5 Stem Packnig
- 6 Stem Bearing
- 7 Taper Pin
- 8 Washer
- 9 Nut
- 10 O-Ring
- 11 Thrust Bearing
- 12 Bottom Plaate
- 13 Bottom Plate Gasket
- 14 Bolt-Hex Head
- 15 Key
- 16 Stem Retainer
- 17 Cap Screw
- 18 Packing Gland
- 19 Bolt-Hex Head
- 20 ID Tag
- 21 Pop Rivet

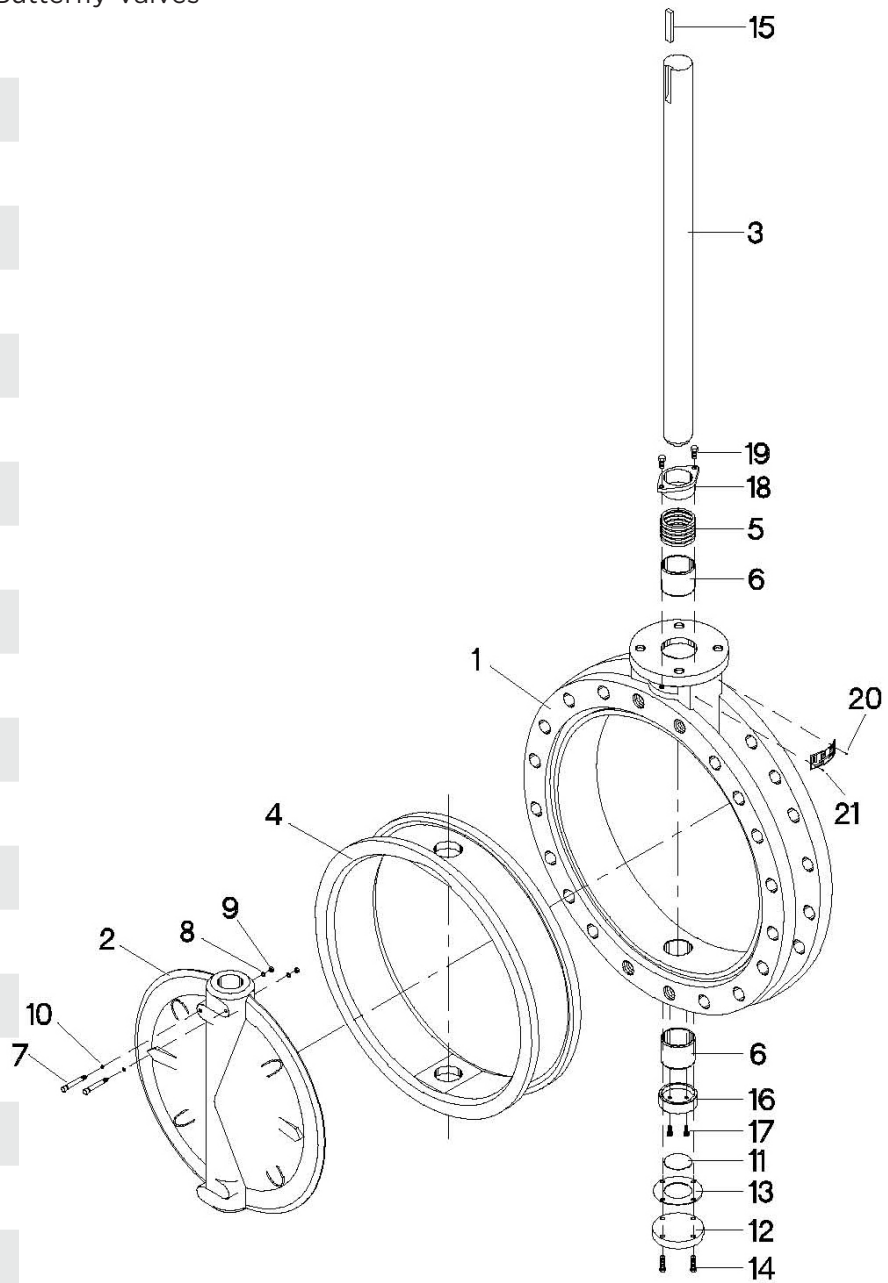



BRAY FLOW CONTROL SOLUTIONS ARE AVAILABLE FOR A VARIETY OF INDUSTRIES.

ENERGY

Mining
Oil & Gas
Power / FGD
Nuclear Power

WATER

Water / Wastewater
Ultra Pure Water
Desalination
Irrigation

INDUSTRIAL

Chemical
Pulp & Paper
Textile
Marine

INFRASTRUCTURE

Beverage & Food
Transportation
Heating, Ventilation & Air Conditioning (HVAC)



US HEADQUARTERS

Bray International, Inc.
13333 Westland East Blvd.
Houston, Texas 77041
Tel: 281.894.5454

CHINA HEADQUARTERS

Bray Controls (ZheJiang) Co. Limited
98 GaoXin # 6 Road
XiaoShan Economic & Development Zone
HangZhou, ZheJiang 311231, P.R. China
Tel: 86 571 8285 2200

EUROPE HEADQUARTERS

Bray Armaturen & Antriebe Europa
Halskestraße 25
47877 Willich
Germany
Tel: +49 2154 8875-0

INDIA HEADQUARTERS

Bray Controls India Pvt. Ltd.
Plot No. H-18 & H-19
SIPCOT Industrial Park
Vallam Vadagal, Echoor Post
Sriperumbudur Taluk
Kancheepuram District
Tamil Nadu - 631 604
Tel: +91-44-67170100



THE SMART CHOICE FOR FLOW CONTROL SINCE 1986.
WITH MORE THAN 300 LOCATIONS WORLDWIDE,
FIND A REPRESENTATIVE NEAR YOU AT **BRAY.COM**

All statements, technical information, and recommendations in this bulletin are for general use only. Consult Bray representatives or factory for the specific requirements and material selection for your intended application. The right to change or modify product design or product without prior notice is reserved. Patents issued and applied for worldwide.

Bray® is a registered trademark of Bray International, Inc.

© 2020 Bray International, Inc.. All rights reserved.

IOM_RSBFV_2020-08