

MK Series High Performance Butterfly – Submittal/Technical Data

10-21-21

Bray MK Series High Performance Butterfly Valves ANSI Class 150 and 300

The Bray McCannalok MK Series high performance butterfly valves set the quality and design standard by which all other high performance valves are measured. The MK Series is ideally suited to high pressure, high temperature, and high cycle HVAC applications as well as mission critical HVAC applications.

Available in ANSI Class 150 ratings, both 2-way and 3-way, and ANSI Class 300 ratings in 2-way configurations, Bray's MK Series valves are provided with a wide variety of direct mount Bray electric and pneumatic actuators and accessories. All valves are tested for bubble tight close-off to API 598 standards at maximum rated differential pressure.



MK Series High Performance Butterfly Valve Specifications

Service	Hot Water, Chilled Water, Condenser Water, Steam	
Body Style	Lug, 2-way for ANSI 150 and ANSI 300 flanges; 3-way for ANSI 150 flanges only	
Size Range	2-1/2" through 20" (DN 50 to 500)	
Flow Characteristic	Modified Equal Percentage	
Body Cold Working Pressure Liquid	ANSI 150	285 PSI (20 BAR)
	ANSI 300	740 PSI (50 BAR)
Close Off Pressure Ratings	See Pages HB-15 to HB-20	
Max Steam Pressure	On/Off Applications	150 PSI (10 BAR)
	Modulating Applications	50 PSI (3.5 BAR)
Leakage	Bubble tight at rated maximum differential pressure	
Maximum Fluid Velocity	30 ft/second (9 m/second)	
Flow Coefficients	See Table on HB-5	
Fluid Temperature Limits	Water -40 to 500°F (-40 to 250°C)	
Materials (other materials available upon request)	Body	Carbon Steel
	Disc	316 Stainless Steel
	Seat	RTFE
	Packing	PTFE (adjustable)
	Stem	17-4 Stainless Steel
	Tee	Ductile Iron (3-Way ANSI 150 valves only)

These performance specifications are nominal and conform to generally acceptable industry standards. Bray Controls is not liable for damages resulting from misapplication or misuse of its products.

HP BFV - Dimensions - 2-Way - ANSI 150 w/ Commercial Electric Actuators

Dimensions - (Valve Body)

2-Way HP BFV Dimensions, 2-1/2" - 4" - Series 41 Butterfly Valves - (ANSI Class 150)														
Valve Model	Size		Cv		A	B	C	D	E	Lug Bolting Data			Weight ¹	
	in.	mm	90°	60°						BC	Holes	Threads	lbs.	kg.
MKL2-_025	2-1/2	65	160	78	4.75	1.88	2.28	3.81	6.38	5.50	4	5/8-11	22	10
MKL2-_030	3	80	185	123	5.25	1.88	2.86	4.09	6.63	6.00	4	5/8-11	30	14
MKL2-_040	4	100	375	250	6.72	2.03	3.72	4.71	7.50	7.50	8	5/8-11	36	16

L N=Normally Open / C=Normally Closed
¹ - Weights shown are for cast steel lug valve bodies only.

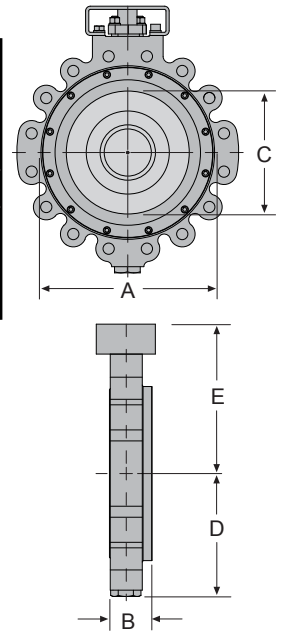

Dimensions - (Commercial Actuators)

Commercial Actuator - Dimensions				
Model Number	F	G	H	Weight lbs
DS-180	7.43	4.00	10.96	6.4
DC-310	7.43	3.95	10.96	4.4
Dual DS-180	11.83	4.00	18.00	12.8
Dual DC-310	11.41	3.95	18.00	8.8

Largest Actuator Dimension Shown

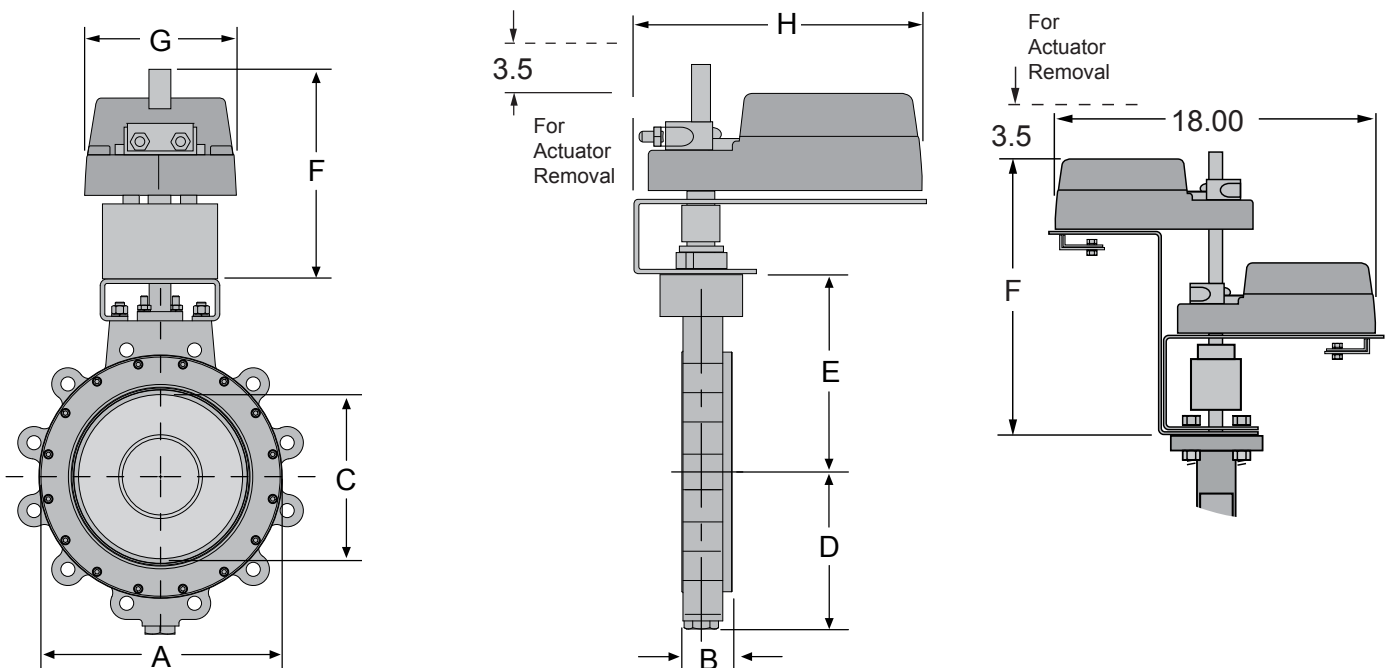

HP BFV - Dimensions - 3-Way - ANSI 150 w/ Commercial Electric Actuators

Dimensions - (Valve Body)

3-Way HP BFV Dimensions, 2-1/2" - 4" - Series 41 Butterfly Valves - (ANSI Class 150)														
Valve Model	Size		Cv		A	B	C	D	E	Lug Bolting Data			Weight ¹	
	in.	mm	90°	60°						BC	Holes	Threads	lbs.	kg.
MKL3-X025	2-1/2	65	160	78	2.50	1.88	3.81	5.00	6.38	5.50	4	5/8-11	22	10
MKL3-X030	3	80	185	123	3.00	1.88	4.09	5.50	6.63	6.00	4	5/8-11	30	14
MKL3-X040	4	100	375	250	4.00	2.03	4.71	6.50	7.50	7.50	8	5/8-11	36	16

¹ X=Configuration number, for 3-Way
¹ - Weights shown are for cast steel lug valve bodies only.
 Add .125 (1/8") to the length for gasket width where the valves meet the tee.

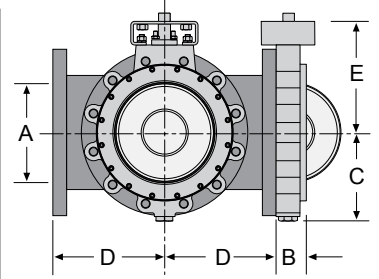

Dimensions - (Commercial Actuators)

Commercial Actuator - Dimensions			
Model Number	F	G	Weight lbs
Dual DS-180	7.43	11.83	12.8
Dual DC-310	7.43	11.41	8.8

Largest Actuator Dimension Shown

3-Way Tee Weights		
Size	Weight	
in.	mm	lbs.
2	50	19
2-1/2	65	27
3	80	39
4	100	62
5	125	79
6	150	96
8	200	155
10	250	270
12	300	380
14	350	435
16	400	550
18	450	665
20	500	855

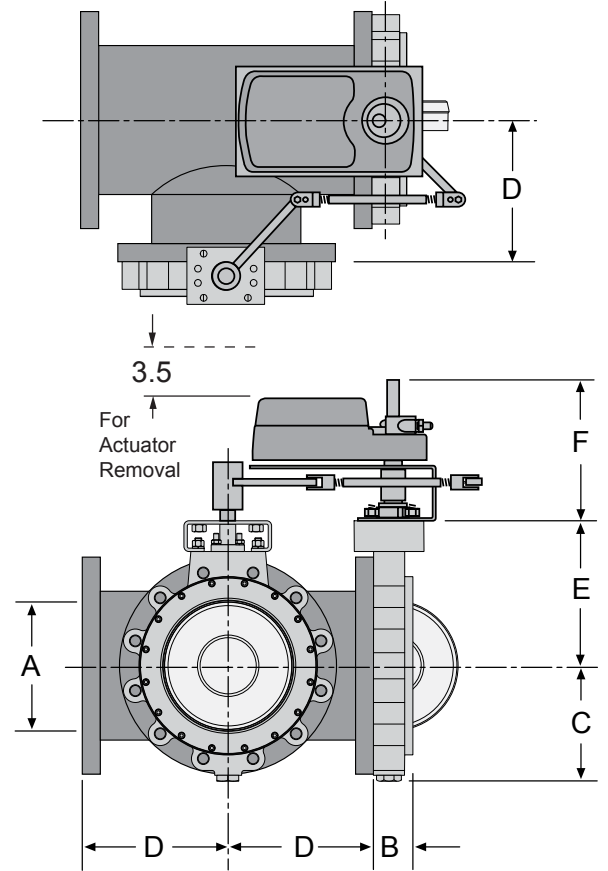
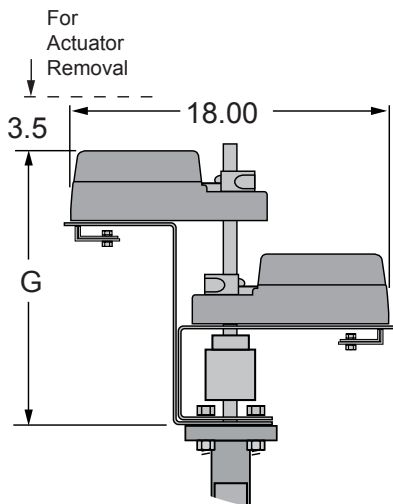

HP BFV - Dimensions - 2-Way - ANSI 150 w/ Industrial Electric Actuators

Dimensions - (Valve Body)

2-Way HP BFV Dimensions, 2-1/2" - 20" - Series 41 Butterfly Valves - (ANSI Class 150)														
Valve Model	Size		Cv		A	B	C	D	E	Lug Bolting Data			Weight ¹	
	in.	mm	90°	60°						BC	Holes	Threads	lbs.	kg.
MKL2-_025	2-1/2	65	160	78	4.75	1.88	2.28	3.81	6.38	5.50	4	5/8-11	22	10
MKL2-_030	3	80	185	123	5.25	1.88	2.86	4.09	6.63	6.00	4	5/8-11	30	14
MKL2-_040	4	100	375	250	6.72	2.03	3.72	4.71	7.50	7.50	8	5/8-11	36	16
MKL2-_050	5	125	790	360	7.62	2.23	4.80	5.07	7.50	8.50	8	3/4-10	49	22
MKL2-_060	6	150	1350	510	8.62	2.23	5.88	5.57	8.00	9.50	8	3/4-10	62	28
MKL2-_080	8	200	2800	1060	10.81	2.40	7.80	6.94	9.50	11.75	8	3/4-10	107	49
MKL2-_100	10	250	4300	1630	13.06	2.75	9.78	8.56	10.75	14.25	12	7/8-9	110	50
MKL2-_120	12	300	6650	2530	15.42	3.08	11.74	10.18	12.25	17.00	12	7/8-9	156	71
MKL2-_140	14	350	7650	2900	17.24	3.73	12.90	11.95	14.50	18.75	12	1-8	228	103
MKL2-_160	16	400	9800	3700	19.50	4.11	14.68	12.94	17.75	21.25	16	1-8	268	122
MKL2-_180	18	450	10500	5100	21.38	4.61	16.60	14.15	20.00	22.75	16	1-1/8-8	400	181
MKL2-_200	20	500	13500	6500	23.62	5.03	18.50	15.26	22.75	25.00	20	1-1/8-8	510	231

\perp N=Normally Open / C=Normally Closed
¹- Weights shown are for cast steel lug valve bodies only.

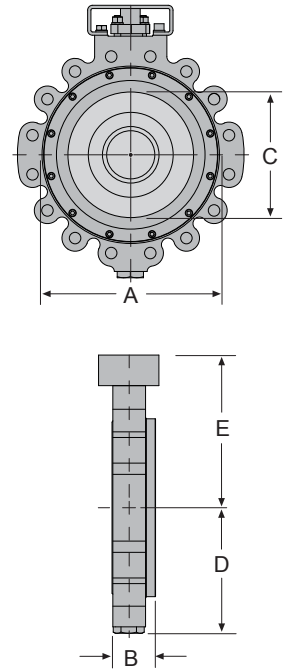

Dimensions - (Industrial Electric Actuators)

Industrial Actuator - Dimensions				
Model Number	F	G	H	Weight lbs
70-0061	5.60	7.50	5.80	12
70-0121/0201	6.60	10.10	7.80	28
70-0301/0501/0651	7.20	12.10	9.50	48
70-1300/1800	12.50	18.80	9.50	118
AU-2130	12.70	32.50	26.00	165
AU-4068	12.30	32.10	28.90	195

Largest Actuator Dimension Shown

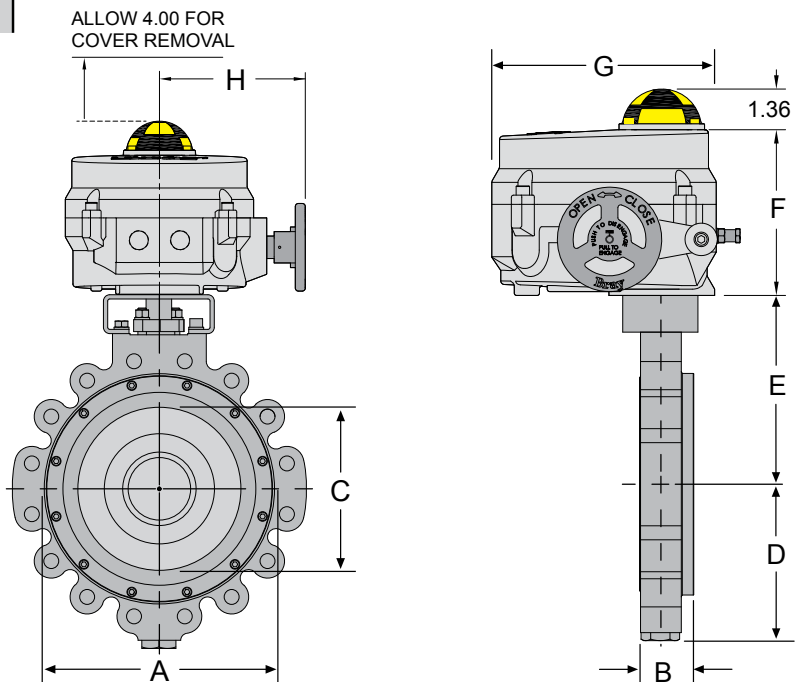

HP BFV - Dimensions - 2-Way - ANSI 300 w/ Industrial Electric Actuators

Dimensions - (Valve Body)

2-Way HP BFV Dimensions, 2-1/2" - 20" - Series 43 Butterfly Valves - (ANSI Class 300)														
Valve Model	Size		Cv		A	B	C	D	E	Lug Bolting Data			Weight ¹	
	in.	mm	90°	60°						BC	Holes	Threads	lbs.	kg.
MKL2-_253	2-1/2	65	160	78	4.75	1.88	2.28	3.81	6.38	5.88	8	3/4-10	22	10
MKL2-_033	3	80	185	123	5.25	1.88	2.86	4.09	6.63	6.63	8	3/4-10	30	14
MKL2-_043	4	100	375	250	6.72	2.03	3.72	4.71	7.50	7.88	8	3/4-10	36	16
MKL2-_053	5	125	790	360	8.25	2.23	4.80	5.13	8.00	9.25	8	3/4-10	49	22
MKL2-_063	6	150	1000	530	8.88	2.42	5.75	6.25	8.75	10.62	12	3/4-10	62	28
MKL2-_083	8	200	2000	950	10.94	2.82	7.56	7.55	10.00	13.00	12	7/8-9	107	49
MKL2-_103	10	250	2650	1200	13.26	3.28	9.44	9.36	11.38	15.25	16	1-8	165	75
MKL2-_123	12	300	4000	1690	15.42	3.62	11.31	10.89	13.50	17.75	16	1-1/8-8	254	115
MKL2-_143	14	350	4100	1770	17.27	4.66	11.38	12.50	18.25	20.25	20	1-1/8-8	458	208
MKL2-_163	16	400	7800	2970	19.50	5.35	14.31	13.88	21.00	22.50	20	1-1/4-8	640	290
MKL2-_183	18	450	9500	4530	21.38	5.98	15.00	15.43	21.00	24.75	24	1-1/4-8	868	394
MKL2-_203	20	500	11000	5400	23.76	6.34	16.50	16.80	22.25	27.00	24	1-1/4-8	1063	482

N=Normally Open / C=Normally Closed
¹- Weights shown are for cast steel lug valve bodies only.

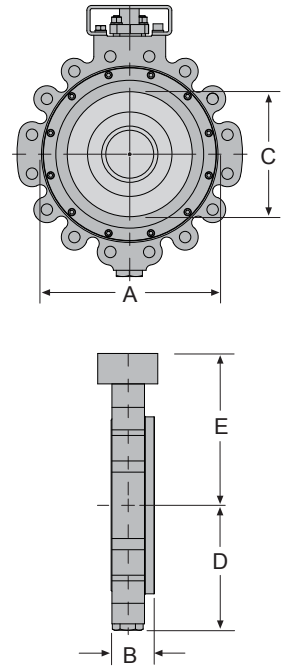

Dimensions - (Industrial Actuators)

Industrial Actuator - Dimensions				
Model Number	F	G	H	Weight lbs
70-0061	5.60	7.50	5.80	12
70-0121/0201	6.60	10.10	7.80	28
70-0301/0501/0651	7.20	12.10	9.50	48
70-1300/1800	12.50	18.80	9.50	118
AU-4068	12.30	32.10	28.90	195

Largest Actuator Dimension Shown

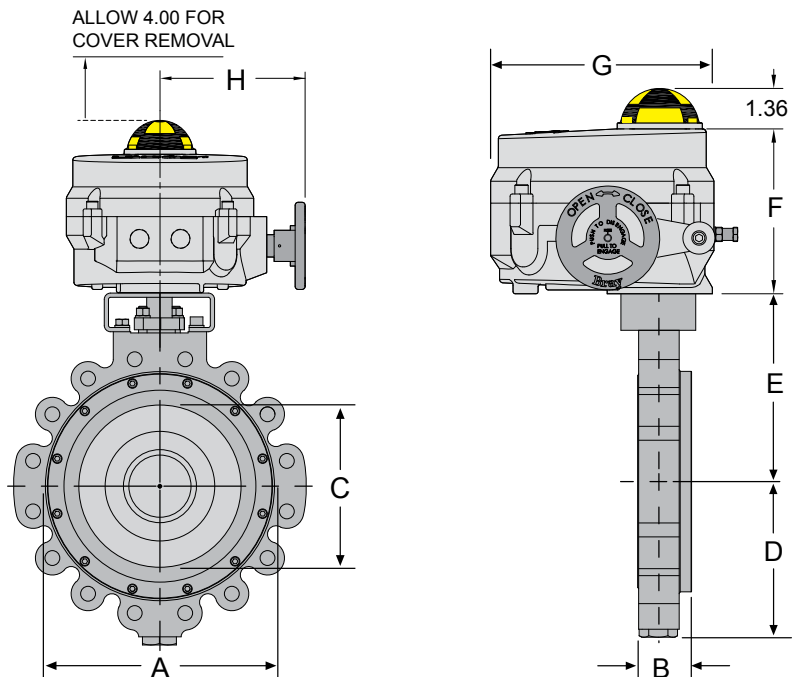

HP BFV - Dimensions - 3-Way - ANSI 150 w/ Industrial Electric Actuators

Dimensions - (Valve Body)

3-Way HP BFV Dimensions, 2-1/2" - 20" - Series 41 Butterfly Valves - (ANSI Class 150)														
Valve Model	Size		Cv		A	B	C	D	E	Lug Bolting Data			Weight ¹	
	in.	mm	90°	60°						BC	Holes	Threads	lbs.	kg.
MKL3-X025	2-1/2	65	160	78	2.50	1.88	3.81	5.00	6.38	5.50	4	5/8-11	22	10
MKL3-X030	3	80	185	123	3.00	1.88	4.09	5.50	6.63	6.00	4	5/8-11	30	14
MKL3-X040	4	100	375	250	4.00	2.03	4.71	6.50	7.50	7.50	8	5/8-11	36	16
MKL3-X050	5	125	790	360	5.00	2.23	5.07	7.50	7.50	8.50	8	3/4-10	49	22
MKL3-X060	6	150	1350	510	6.00	2.23	5.57	8.00	8.00	9.50	8	3/4-10	62	28
MKL3-X080	8	200	2800	1060	8.00	2.40	6.94	9.00	9.50	11.75	8	3/4-10	107	49
MKL3-X100	10	250	4300	1630	10.00	2.75	8.56	11.00	10.75	14.25	12	7/8-9	110	50
MKL3-X120	12	300	6650	2530	12.00	3.08	10.18	12.00	12.25	17.00	12	7/8-9	156	71
MKL3-X140	14	350	7650	2900	14.00	3.73	11.95	14.00	14.50	18.75	12	1-8	228	103
MKL3-X160	16	400	9800	3700	15.00	4.11	12.94	15.00	17.75	21.25	16	1-8	268	122
MKL3-X180	18	450	10500	5100	18.00	4.61	14.15	16.50	20.00	22.75	16	1-1/8-8	400	181
MKL3-X200	20	500	13500	6500	20.00	5.03	15.26	18.00	22.75	25.00	20	1-1/8-8	510	231

¹ Configuration Number for 3-Way
¹ - Weights shown are for cast steel lug valve bodies only.
 Add .125 (1/8") to the length for gasket width where the valves meet the tee.

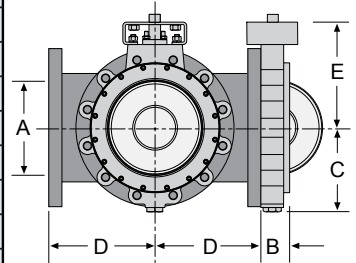

Dimensions - (Industrial Electric Actuators)

Industrial Actuator - Dimensions				
Model Number	F	G	H	Weight lbs
70-0061	8.60	7.50	5.80	12
70-0121	9.60	10.10	7.80	28
70-0201	10.73	10.10	7.80	28
70-0501/0651	11.33	12.10	9.50	48
70-1300	18.50	12.10	9.50	118
AU-2130	18.70	32.50	26.00	165
AU-4068	25.20	32.10	28.90	195

Largest Actuator Dimension Shown

3-Way Tee Weights

Size	Weight lbs.	
in.	mm	
2	50	19
2-1/2	65	27
3	80	39
4	100	62
5	125	79
6	150	96
8	200	155
10	250	270
12	300	380
14	350	435
16	400	550
18	450	665
20	500	855

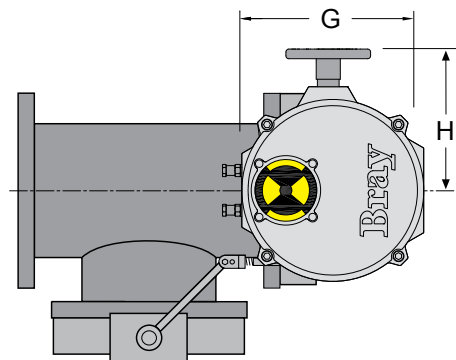
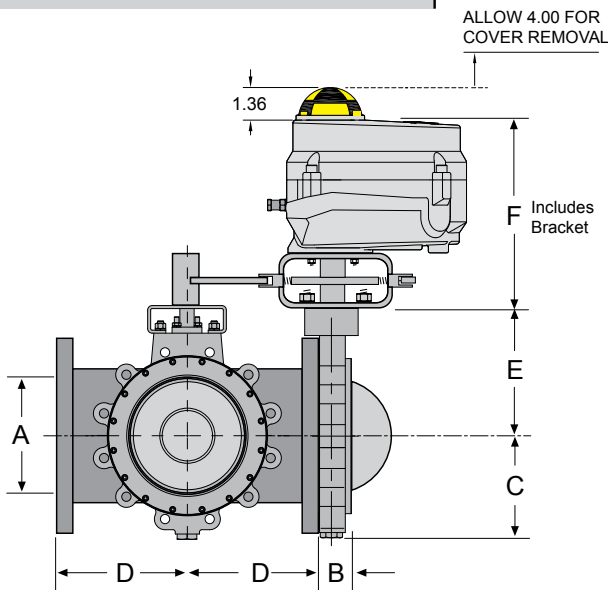

HP BFV - Dimensions - 2-Way - ANSI 150 w/ Pneumatic Actuators

Dimensions - (Valve Body)

2-Way HP BFV Dimensions, 2-1/2" - 20" - Series 41 Butterfly Valves - (ANSI Class 150)														
Valve Model	Size		Cv		A	B	C	D	E	Lug Bolting Data			Weight ¹	
	in.	mm	90°	60°						BC	Holes	Threads	lbs.	kg.
MKL2_025	2-1/2	65	160	78	4.75	1.88	2.28	3.81	6.38	5.50	4	5/8-11	22	10
MKL2_030	3	80	185	123	5.25	1.88	2.86	4.09	6.63	6.00	4	5/8-11	30	14
MKL2_040	4	100	375	250	6.72	2.03	3.72	4.71	7.50	7.50	8	5/8-11	36	16
MKL2_050	5	125	790	360	7.62	2.23	4.80	5.07	7.50	8.50	8	3/4-10	49	22
MKL2_060	6	150	1350	510	8.62	2.23	5.88	5.57	8.00	9.50	8	3/4-10	62	28
MKL2_080	8	200	2800	1060	10.81	2.40	7.80	6.94	9.50	11.75	8	3/4-10	107	49
MKL2_100	10	250	4300	1630	13.06	2.75	9.78	8.56	10.75	14.25	12	7/8-9	110	50
MKL2_120	12	300	6650	2530	15.42	3.08	11.74	10.18	12.25	17.00	12	7/8-9	156	71
MKL2_140	14	350	7650	2900	17.24	3.73	12.90	11.95	14.50	18.75	12	1-8	228	103
MKL2_160	16	400	9800	3700	19.50	4.11	14.68	12.94	17.75	21.25	16	1-8	268	122
MKL2_180	18	450	10500	5100	21.38	4.61	16.60	14.15	20.00	22.75	16	1-1/8-8	400	181
MKL2_200	20	500	13500	6500	23.62	5.03	18.50	15.26	22.75	25.00	20	1-1/8-8	510	231

N=Normally Open / C=Normally Closed

¹. Weights shown are for cast steel lug valve bodies only.

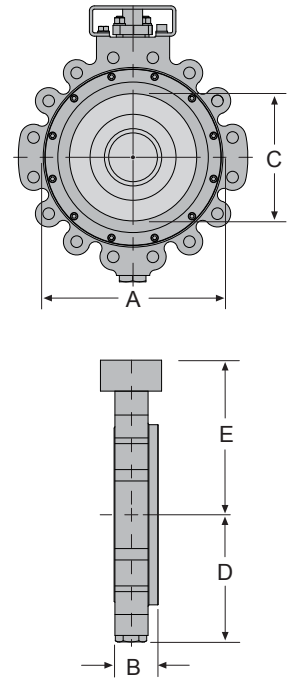

Dimensions - (Series 92/93 Pneumatic Actuator)

Series 92/93 - Dimensions						
Model Number	F	G	H	Weight lbs		
				Double Acting	Spring Return	
92/93-083	5.43	7.40	4.07	6.3	7.8	
92/93-093	5.78	8.59	4.44	8.5	10.4	
92/93-119	7.28	12.40	5.15	16.9	21.4	
92/93-128	8.09	12.31	5.58	21.0	26.5	
92/93-160	9.36	15.54	7.17	38.8	50.8	
92/93-210	11.62	19.57	8.97	77.8	104.1	
92/93-255	13.49	28.78	10.79	167.0	199.0	

Dimensions are in Inches

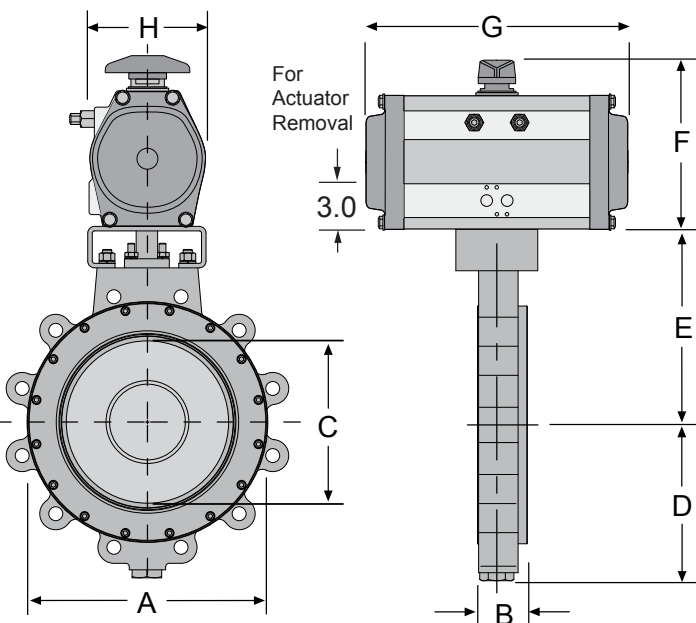
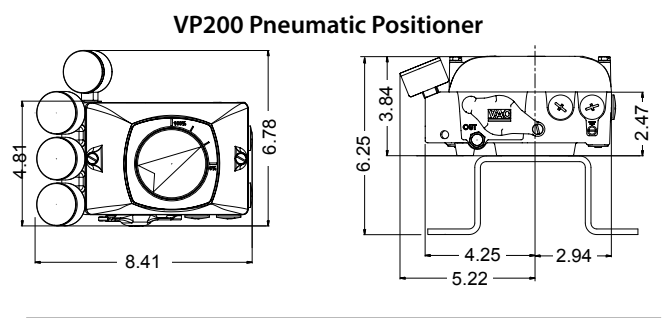

Series 5A Switch Box

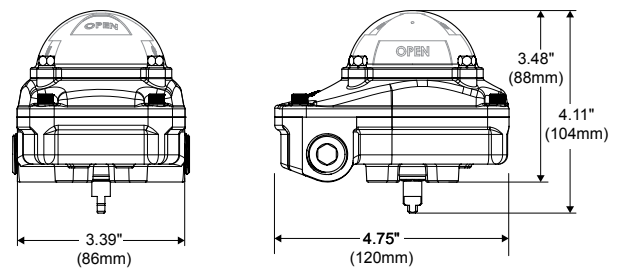

Series 6A Electro Pneumatic Positioner

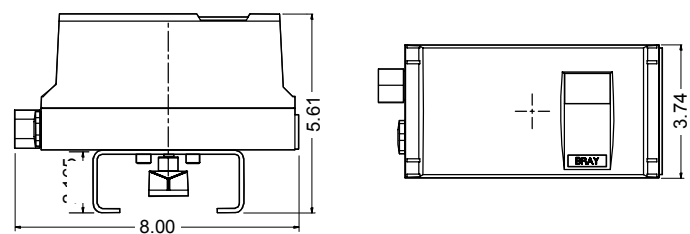

HP BFV - Dimensions - 2-Way - ANSI 300 w/ Pneumatic Actuators

Dimensions - (Valve Body)

2-Way HP BFV Dimensions, 2-1/2" - 20" - Series 43 Butterfly Valves - (ANSI Class 300)															
Valve Model	Size		Cv		A	B	C	D	E	Lug Bolting Data			Weight ¹		
	in.	mm	90°	60°						BC	Holes	Threads	lbs.	kg.	
MKL2_253	2-1/2	65	160	78	4.75	1.88	2.28	3.81	6.38	5.88	8	3/4-10	22	10	
MKL2_033	3	80	185	123	5.25	1.88	2.86	4.09	6.63	6.63	8	3/4-10	30	14	
MKL2_043	4	100	375	250	6.72	2.03	3.72	4.71	7.50	7.88	8	3/4-10	36	16	
MKL2_053	5	125	790	360	8.25	2.23	4.80	5.13	8.00	9.25	8	3/4-10	49	22	
MKL2_063	6	150	1000	530	8.88	2.42	5.75	6.25	8.75	10.62	12	3/4-10	62	28	
MKL2_083	8	200	2000	950	10.94	2.82	7.56	7.55	10.00	13.00	12	7/8-9	107	49	
MKL2_103	10	250	2650	1200	13.26	3.28	9.44	9.36	11.38	15.25	16	1-8	165	75	
MKL2_123	12	300	4000	1690	15.42	3.62	11.31	10.89	13.50	17.75	16	1-1/8-8	254	115	
MKL2_143	14	350	4100	1770	17.27	4.66	11.38	12.50	18.25	20.25	20	1-1/8-8	458	208	
MKL2_163	16	400	7800	2970	19.50	5.35	14.31	13.88	21.00	22.50	20	1-1/4-8	640	290	
MKL2_183	18	450	9500	4530	21.38	5.98	15.00	15.43	21.00	24.75	24	1-1/4-8	868	394	
MKL2_203	20	500	11000	5400	23.76	6.34	16.50	16.80	22.25	27.00	24	1-1/4-8	1063	482	

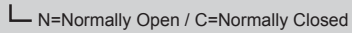

¹ - Weights shown are for cast steel lug valve bodies only.

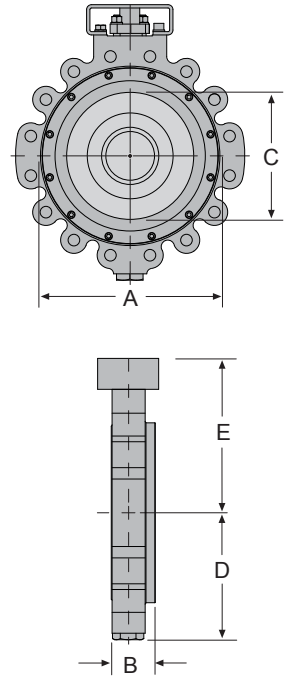

Dimensions - (Series 92/93 Pneumatic Actuator)

Series 92/93 - Dimensions						
Model Number	F	G	H	Weight lbs		
				Double Acting	Spring Return	
92/93-083	5.43	7.40	4.07	6.3	7.8	
92/93-093	5.78	8.59	4.44	8.5	10.4	
92/93-119	7.28	12.40	5.15	16.9	21.4	
92/93-128	8.09	12.31	5.58	21.0	26.5	
92/93-160	9.36	15.54	7.17	38.8	50.8	
92/93-210	11.62	19.57	8.97	77.8	104.1	
92/93-255	13.49	28.78	10.79	167.0	199.0	

Dimensions are in Inches

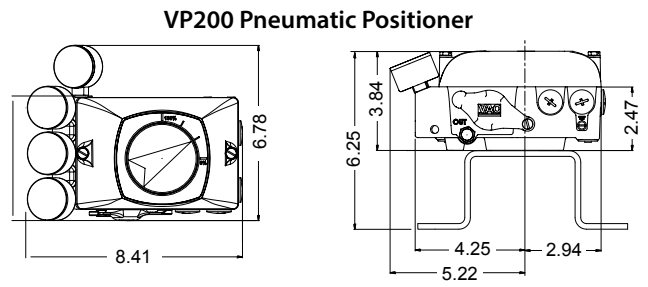

Series 5A Switch Box

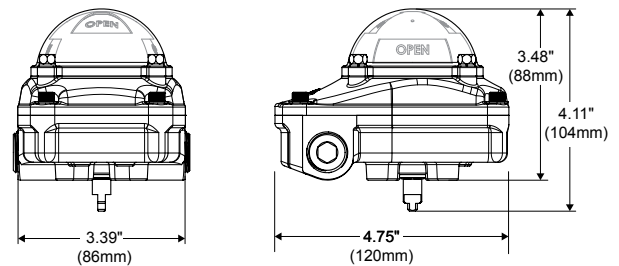

Series 6A Electro Pneumatic Positioner

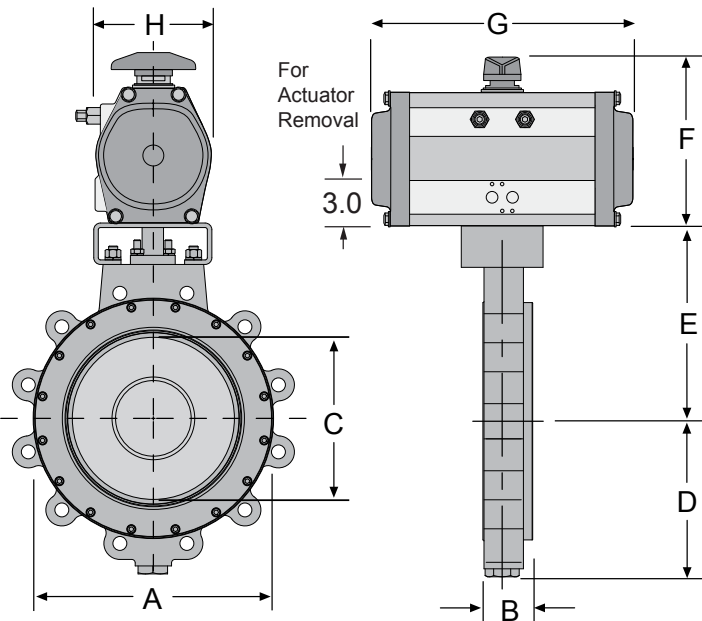
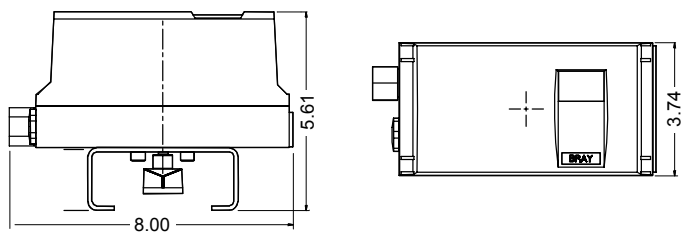

HP BFV - Dimensions - 3-Way - ANSI 150 w/ Pneumatic Actuators

Dimensions - (Valve Body)

3-Way HP BFV Dimensions, 2-1/2" - 20" - Series 41 Butterfly Valves - (ANSI Class 150)														
Valve Model	Size		Cv		A	B	C	D	E	Lug Bolting Data			Weight ¹	
	in.	mm	90°	60°						BC	Holes	Threads	lbs.	kg.
MKL3-X025	2-1/2	65	160	78	2.50	1.88	3.81	5.00	6.38	5.50	4	5/8-11	22	10
MKL3-X030	3	80	185	123	3.00	1.88	4.09	5.50	6.63	6.00	4	5/8-11	30	14
MKL3-X040	4	100	375	250	4.00	2.03	4.71	6.50	7.50	7.50	8	5/8-11	36	16
MKL3-X050	5	125	790	360	5.00	2.23	5.07	7.50	7.50	8.50	8	3/4-10	49	22
MKL3-X060	6	150	1350	510	6.00	2.23	5.57	8.00	8.00	9.50	8	3/4-10	62	28
MKL3-X080	8	200	2800	1060	8.00	2.40	6.94	9.00	9.50	11.75	8	3/4-10	107	49
MKL3-X100	10	250	4300	1630	10.00	2.75	8.56	11.00	10.75	14.25	12	7/8-9	110	50
MKL3-X120	12	300	6650	2530	12.00	3.08	10.18	12.00	12.25	17.00	12	7/8-9	156	71
MKL3-X140	14	350	7650	2900	14.00	3.73	11.95	14.00	14.50	18.75	12	1-8	228	103
MKL3-X160	16	400	9800	3700	16.00	4.11	12.94	15.00	17.75	21.25	16	1-8	268	122
MKL3-X180	18	450	10500	5100	18.00	4.61	14.15	16.50	20.00	22.75	16	1-1/8-8	400	181
MKL3-X200	20	500	13500	6500	20.00	5.03	15.26	18.00	22.75	25.00	20	1-1/8-8	510	231

¹ Configuration Number for 3-Way ¹ - Weights shown are for cast steel lug valve bodies only.
Add .125 (1/8") to the length for gasket width where the valves meet the tee.

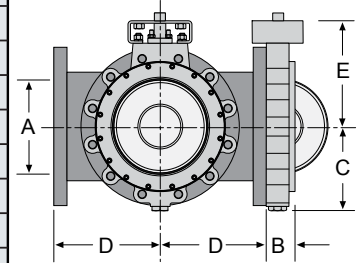

Dimensions - (Series 92/93 Pneumatic Actuator)

Series 92 - Dimensions				
Model Number	F	G	H	Weight lbs Double Acting
92-083	8.43	7.40	4.07	6.3
92-093	8.78	8.59	4.44	8.5
92-119	10.28	12.40	5.15	16.9
92-128	12.22	12.31	5.58	21.0
92-160	13.49	15.54	7.17	38.8
92-210*	17.62	19.57	8.97	77.8
92-255*	23.49	28.78	10.79	167.0

Dimensions are in Inches *Largest dimension shown

Series 93 - Dimensions				
Model Number	F	G	H	Weight lbs Spring Return
93-083x	8.43	7.40	4.07	7.8
93-093x	8.78	8.59	4.44	10.4
93-119x	10.28	12.40	5.15	21.4
93-128x	11.09	12.31	5.58	26.5
93-160x	12.36	15.54	7.17	50.8
93-210x	15.75	19.57	8.97	104.1
93-255x*	19.49	28.78	10.79	199.0

Dimensions are in Inches *Largest dimension shown

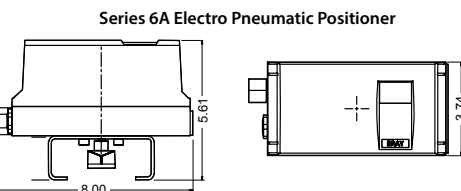
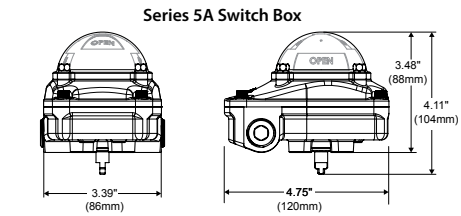
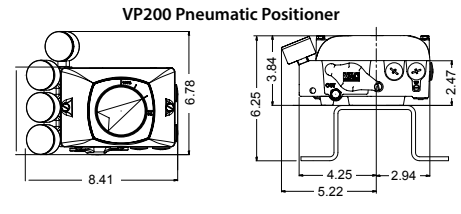

3-Way Tee Weights		
Size in.	mm	Weight lbs.
2	50	19
2-1/2	65	27
3	80	39
4	100	62
5	125	79
6	150	96
8	200	155
10	250	270
12	300	380
14	350	435
16	400	550
18	450	665
20	500	855

