

Identification and Overview

BAPI's ZPM is designed for quick and easy field installation. The outputs, ranges, units, directionality, and response time are all easily set in the field without powering the unit.

The optional LCD display helps with troubleshooting because it displays the actual pressure regardless of the selected pressure range. Three LEDs on the face of the unit indicate when the pressure is "Out of Range Low", "In Range" or "Out of Range High".

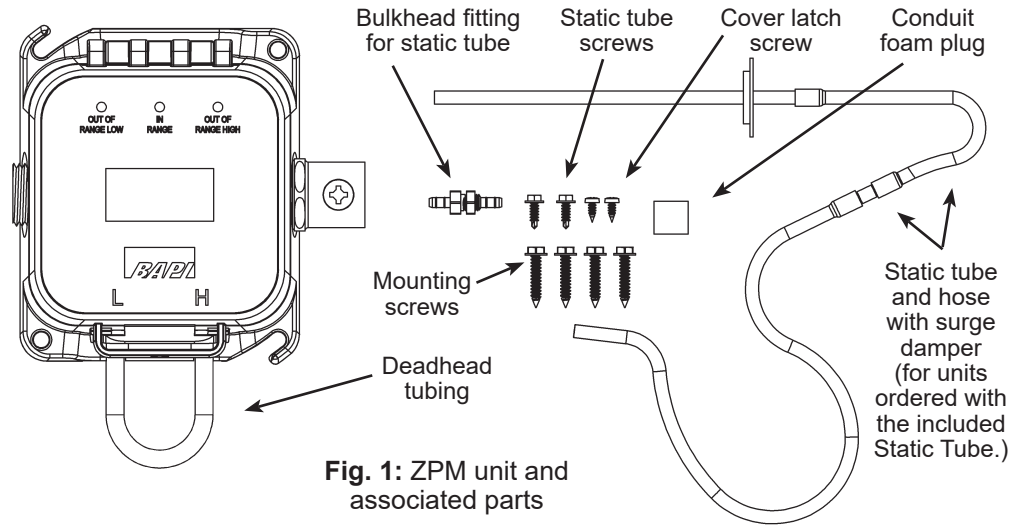

Fig. 1: ZPM unit and associated parts

Switch Setup - Outputs, Ranges, Units/Response

NOTE! Always follow the Auto-Zero procedure after changing settings.

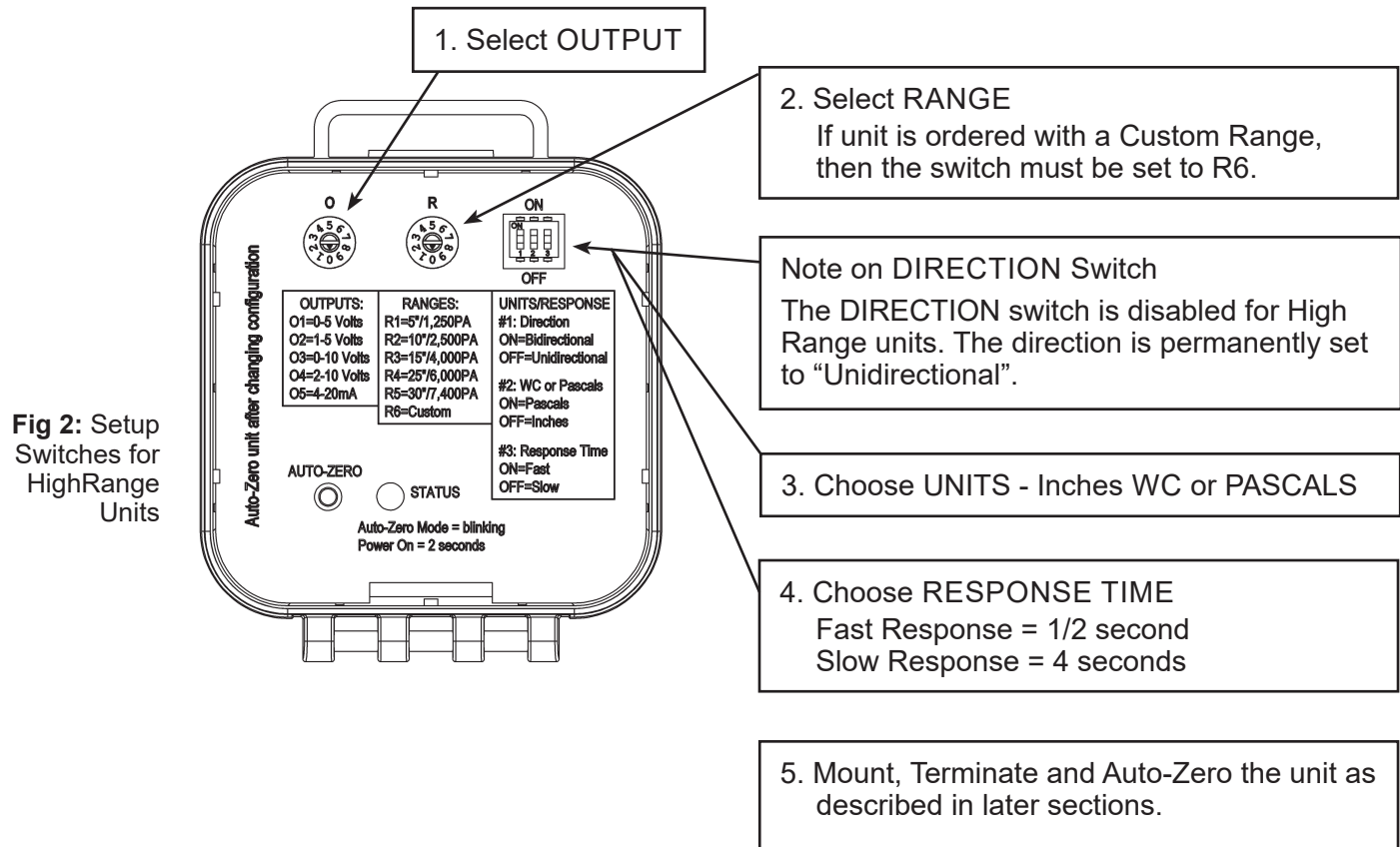

Fig 2: Setup Switches for HighRange Units

Mounting

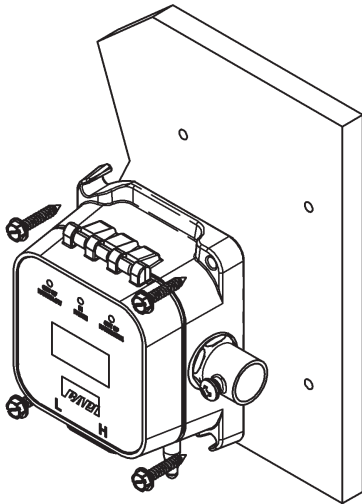

Fig. 3: ZPM Mounting
(for units without Attached Tube option)

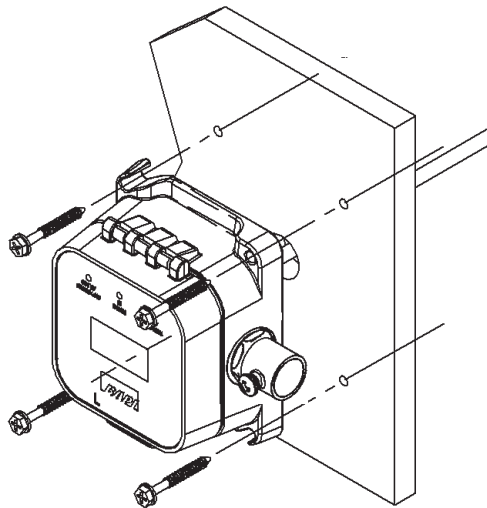
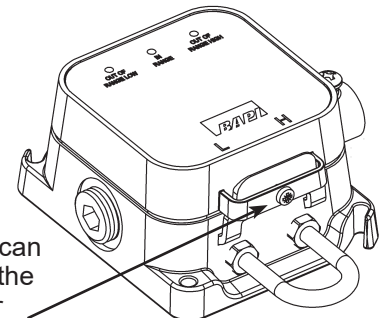

Fig. 4: ZPM Mounting
(for units with Attached Tube option)

Attach the unit to its mounting surface with four self-tapping #10x3/4" sheet metal screws through the holes in the mounting feet. The preferred mounting orientation is with the pressure ports facing down.

After Auto-Zeroing, remove the deadhead tubing and push the system tubing onto the port nipple without creating any kinks or holes.



A locking screw can be inserted into the hole in the cover latch to prevent unintentional cover openings.

Fig. 5: Cover Latch Screw

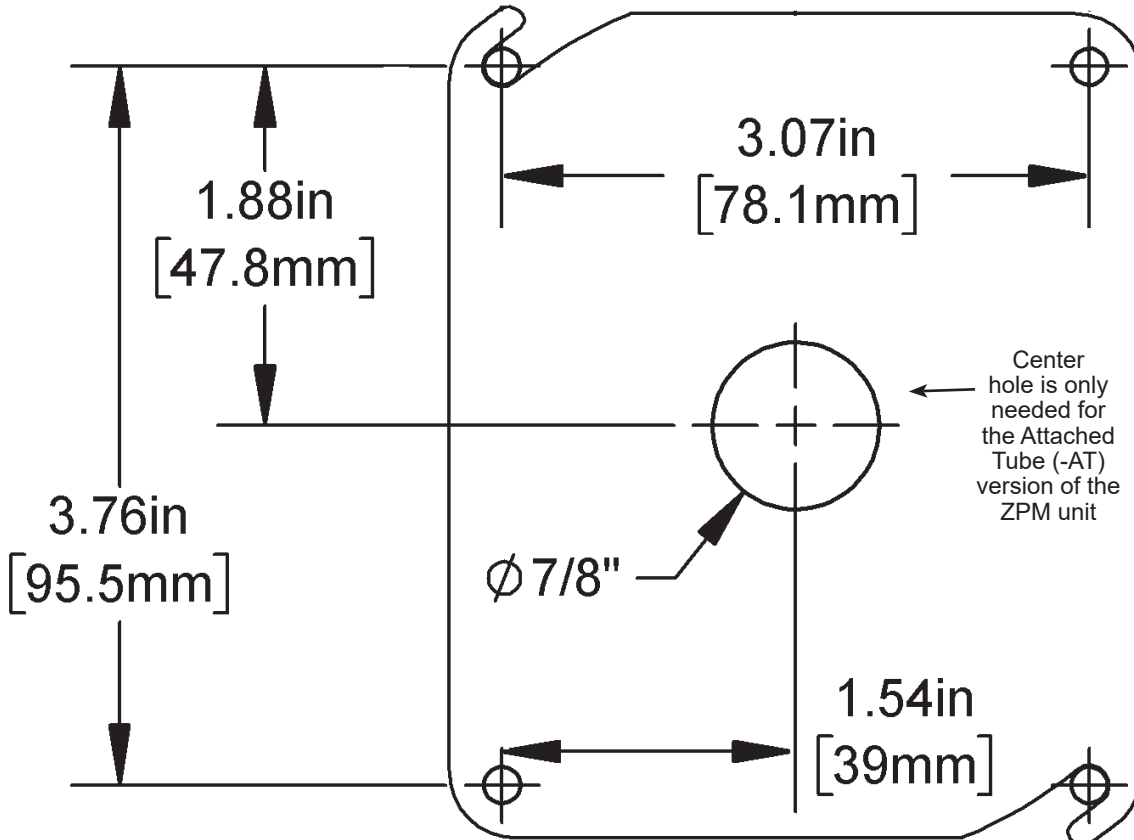

Fig. 6: Mounting Hole Template - shown actual size
(BAPI recommends creating 5/32" pilot holes for the #10x3/4" self-tapping mounting screws.)

Output Termination



BAPI recommends wiring the product with power disconnected. Proper supply voltage, polarity and wiring connections are important to a successful installation. Not observing these recommendations may damage the product and void the warranty.

To ensure that all wires are properly terminated, twist the stripped ends of each wire together before inserting into the terminals. Gently tug on the wire after inserting into the terminal to verify a good connection.

Table 1: ZPM Termination

Output Signal	PWR Terminal	GND Terminal	OUT Terminal
4 to 20 mA	7 to 40 VDC	4 to 20 mA Signal To Controller Analog Input	Not Used
0 to 5 or 1 to 5 VDC	7 to 40 VDC or 18 to 32 VAC	To Controller Ground	VDC Signal To Controller Analog Input
0 to 10 or 2 to 10 VDC	13 to 40 VDC or 18 to 32 VAC	To Controller Ground	VDC Signal To Controller Analog Input

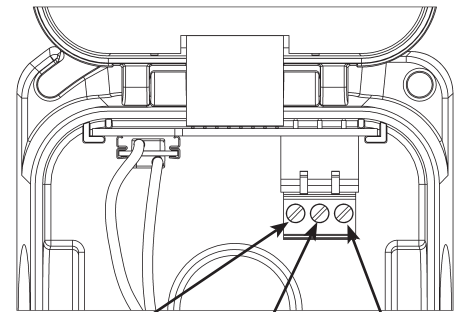

PWR Terminal GND/4-20 Terminal Vout Terminal

Fig. 7: ZPM Wiring Terminals

Auto-Zero and Status LED Operation

AUTO-ZERO OPERATION

Auto-Zeroing must be done after the initial setup, changing mounting orientation or changing any settings. For most applications, perform an auto-zero whenever it appears that the sensor has drifted. For critical applications, the unit should be zeroed 2-3 times a year.

1. Power must be on.
2. Detach system tubing and deadhead ports using the supplied tubing or other short length of tubing. Do not kink tubing.
3. Press and hold the Auto-Zero button for 1-2 seconds. The Status LED will stop flashing when completed.
4. Remove deadhead tubing and reattach system tubing.

AUTO-ZERO OPERATION (Units w/ Attached Tube)

1. Power must be on.
2. Disconnect system tubing from the low pressure brass fitting and attach the supplied 6" deadhead tubing to the brass fitting.
3. Disconnect the short clear tubing from the 90° black high pressure Attached Tube fitting with your fingers (Fig 9). A pliers may cut the tubing.
4. Connect the clear tubing to the supplied, straight black fitting on the 6" tubing (Fig 9). Do not kink the tubing.
5. Press and hold the Auto-Zero button for 1-2 seconds. The Status LED will stop flashing when completed.
6. Disconnect the deadhead tubing and reattach the clear tubing and system tubing. Confirm that the clear tubing is pressed all of the way onto the fitting and that it is not kinked.

STATUS LED OPERATION

LED Off: No power is applied or the unit is in 4 to 20 mA Mode

LED Solid (On): LED is on when power is applied and a VDC output is selected. When 4 to 20 mA output is selected, the light is on for 2 seconds at power up then goes off.

LED Flashing: Auto-Zero. The LED will flash for about 10 seconds.

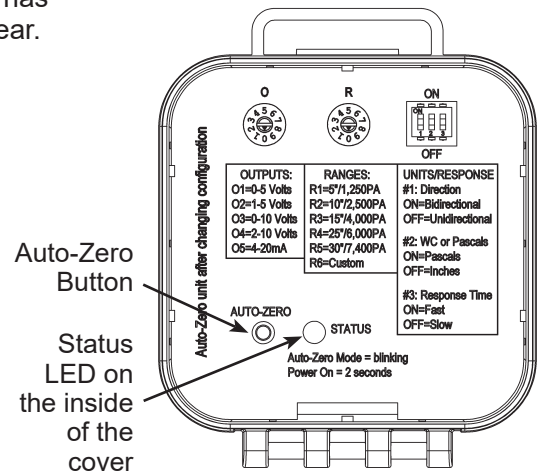

Fig 8: Auto-Zero and Status LEDs

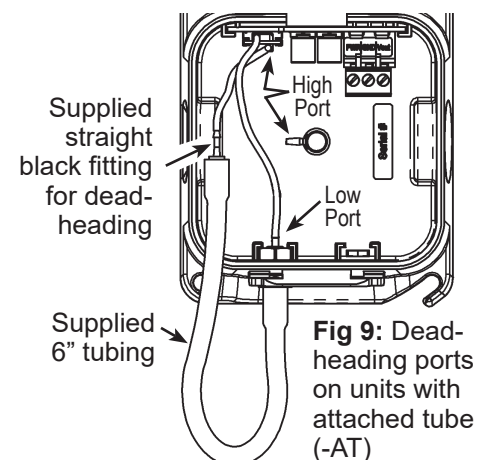

Fig 9: Dead-heading ports on units with attached tube (-AT)

Typical Applications

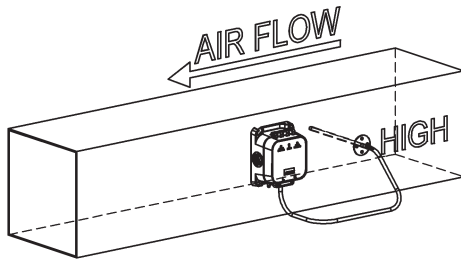

Fig. 10: Duct Static Pressure Monitoring
(ZPM Pressure Sensor mounted on the duct with a Static Pressure Probe in the duct.)

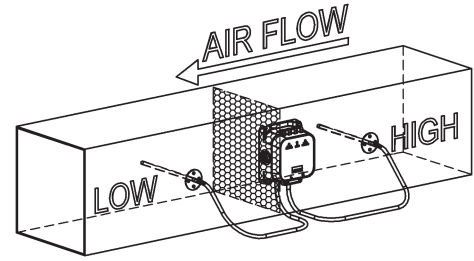

Fig. 11: Air Filter Pressure Drop Monitoring
(ZPM Pressure Sensor mounted on the duct with a Static Pressure Probe on either side of the filter in a duct.)

NOTE: Best practice is to form a drip loop in the tubing to prevent condensation from reaching the ZPM.

Troubleshooting

POSSIBLE PROBLEMS:

Status LED does not light

Status LED is flashing

Display is alternating between a number and "Err"

Output stuck (high or low)

Output not tracking pressure properly

POSSIBLE SOLUTIONS:

- Check power connections for proper power

- Sensor is set to 4 to 20mA output

- The unit may be performing an auto-zero. Wait 10 seconds and check again.

- The measurement is out of selected range.

- Remove pressure from ports and perform auto-zero procedure

- Check rotary switch for proper pressure range selection

- Check rotary switch for proper output range selection

Specifications

Power:

7 to 40 VDC (4 to 20 mA Output)

7 to 40 VDC or 18 to 32 VAC (0 to 5 or 1 to 5 VDC Output)

13 to 40 VDC or 18 to 32 VAC (0 to 10 or 2 to 10 VDC Output)

Power Consumption:

20 mA max, DC only at 4 to 20 mA Output

5.2 mA max DC at 0 to 5 or 0 to 10 VDC Output

0.12 VA max AC at 0 to 5 or 0 to 10 VDC Output

Load Resistance:

4 to 20 mA Output 850 Ω Maximum @ 24 VDC

0 to 5 or 0 to 10 VDC Output 6K Ω Minimum

Accuracy: $\pm 0.25\%$ FS at 72°F (22°C) for All Units

High Range Unit: $\pm 0.075"$ WC (± 18.66 Pa)

Stability: $\pm 0.25\%$ FS per year

Overpressure: Proof 350" WC (87 kPa)

Media: Clean, dry, non-corrosive gases

Compensated Temperature Range:

32 to 122°F (0 to 50°C)

Environmental Operating Range: -4 to 140°F (-20 to 60°C)

Storage Temperature: -40 to 185°F (-40 to 85°C)

Humidity: 0 to 95% RH, non-condensing

Wiring:

2 wires (4 to 20mA Current loop)

3 wires (AC or DC powered, VDC output)

Port Size: 1/4" barb

Enclosure Material:

UV-resistant Polycarbonate, UL94 V-0

Enclosure Rating: IP44, NEMA 2

Agency:

CE EN 61326-1:2013

EMC (Industrial

Electromagnetic

Environment), UL,

RoHS

Selectable High Ranges

<u>Inches WC</u>	<u>Pascals</u>
0 to 5.....	0 to 1,250
0 to 10.....	0 to 2,500
0 to 15.....	0 to 4,000
0 to 25.....	0 to 6,000
0 to 30.....	0 to 7,400

Specifications subject to change without notice.