



ANALOG INTERFACE SERIES

Installation & Operation Instructions
ARM2

Phone: 1-888-967-5224
Website: workaci.com

GENERAL INFORMATION

The ARM2 will accept a single analog (voltage or current) signal and split that signal into two DC non-isolated current sourcing outputs that can be re-scaled. Its primary application is as a signal splitter. The outputs are always scaled identically and will always track each other. The top-adjust trimmer potentiometers can be used to make fine adjustments to output ranges for maximum flexibility. This device can attenuate an input signal to 100%. The ARM2 also has an adjustable gain and offset. The output gain can be adjusted from 1 to 20 times the input (gain will vary depending on input). The ARM2 also has the ability to reverse an input signal.

MOUNTING INSTRUCTIONS

Circuit board may be mounted in any position. If circuit board slides out of snap track, a nonconductive "stop" may be required. Use only fingers to remove board from snap track. Slide out of snap track or push against side of snap track and lift that side of the circuit board to remove. **Do not flex board or use tools.**

FIGURE 1: DIMENSIONS

BOARD

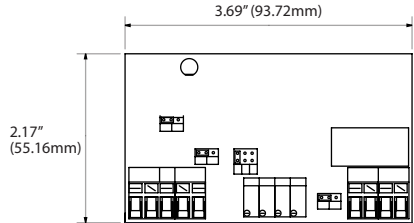

SNAP TRACK

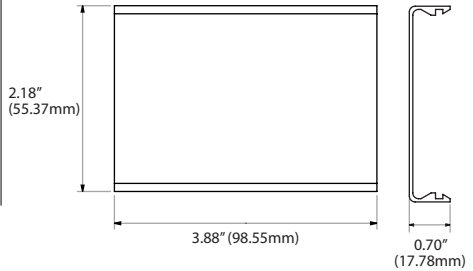

WIRING INSTRUCTIONS

PRECAUTIONS

- **Remove power before wiring. Never connect or disconnect wiring with power applied.**
- **When using a shielded cable, ground the shield only at the controller end. Grounding both ends can cause a ground loop.**
- **It is recommended you use an isolated UL-listed class 2 transformer when powering the unit with 24 VAC. Failure to wire the devices with the correct polarity when sharing transformers may result in damage to any device powered by the shared transformer.**
- **If the 24 VDC or 24VAC power is shared with devices that have coils such as relays, solenoids, or other inductors, each coil must have an MOV, DC/AC Transorb, Transient Voltage Suppressor (ACI Part: 142583), or diode placed across the coil or inductor. The cathode, or banded side of the DC Transorb or diode, connects to the positive side of the power supply. Without these snubbers, coils produce very large voltage spikes when de-energizing that can cause malfunction or destruction of electronic circuits.**
- **All wiring must comply with all local and National Electric Codes.**



FIGURE 2: WIRING

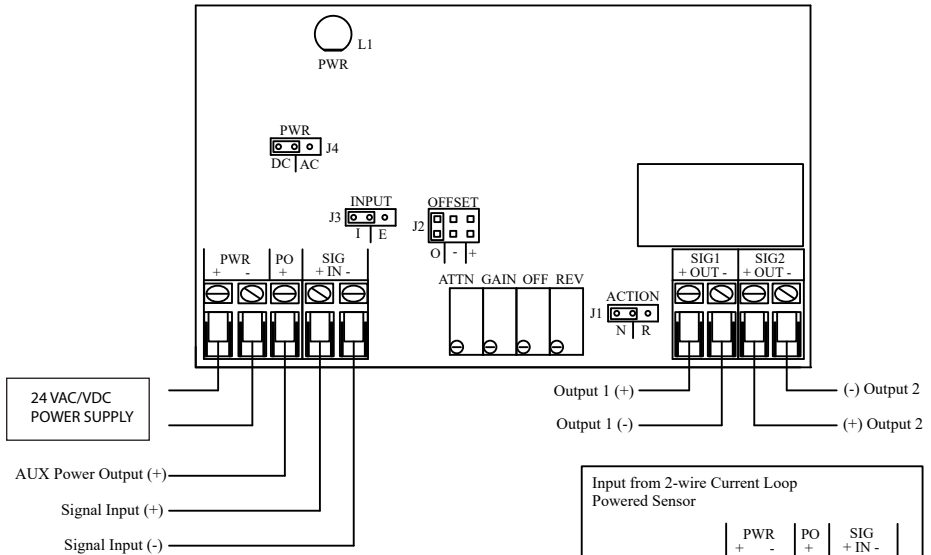

Note: The ARM2 does NOT isolate the input signals from the output signals. Use the Analog Isolation Module (AIM1, AIM2) if you need to isolate the input signals from output signals.

FACTORY CALIBRATION

The ARM2 is set as follows:

- No Attenuation to the Input Signal
- Voltage Input Signal
- Current Output Signal
- Normal Acting Output Signal
- No Offset to the Output Signal
- Gain of 1 to the Output Signal (1:1). All four (4) pots should be full counterclockwise (you can check them as they may make a slight clicking sound at the end of their range).

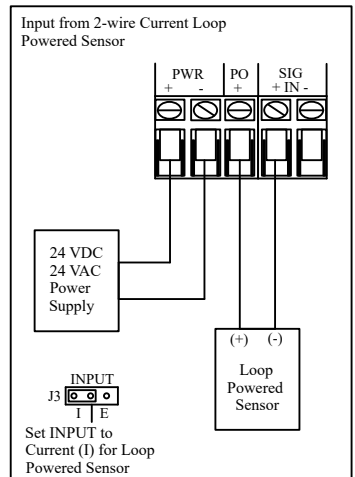

The ARM2 can be ordered calibrated to your specifications or you may follow the procedure below to set your own calibration.

Be sure to check the input, output, GAIN and OFFSET specifications of the ARM2. It is possible that the ARM2 cannot re-scale to your requirements.

Calibration

Complete the following steps to change the calibration of the ARM2. You will need a digital volt/current meter, a 24 VDC power supply and a voltage input signal simulator. (A 5K ohm or greater trim pot can be used as a voltage input signal simulator by connecting one end of the trim pot resistance winding to the (+) 24 of the power supply, the other end of the trim pot resistance winding to the (-) 24 of the power supply and the wiper end of the trim pot to the "IN" terminal of the ARM2).



EQUIVALENT CALIBRATION VOLTAGE

Use a voltage signal for your input signal during calibration: this makes both the procedure and the explanation easier. If you will require a current input when you are finished, use the equation below to find the equivalent calibration voltage to use during the calibration procedure:

Equivalent Calibration Voltage = Required Input Signal Amps x 250

Example: 1 VDC is the equivalent calibration voltage for a 4 milliamp input signal ($1 = .004 \times 250$) or 5 VDC is the equivalent calibration voltage for a 20 milliamp input signal ($5 = .020 \times 250$).

Step 1) Trim Pot Presets:

Set all pots as follows to start (These are 25 turn trim pots with no hard stops; they may make a slight clicking sound at either end of their range):

Turn the following pots full counter clockwise (25 turns):

GAIN = gain of 1

OFFSET = 0 volts offset

REV = 0 volts reverse

ATTN = (no input signal attenuation)

FIGURE 3: JUMPER SHUNTS

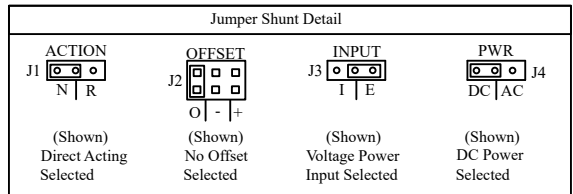

Step 2) Jumper Shunt Presets

J1- NORMAL OR REVERSE ACTING: Set in "N" position for direct acting output signal. (If you require a reverse acting output signal, you will set this shunt in the "R" position in Step 7).

J2 - OFFSET: Set in the "O" position for no offset to the output. (If you will require a "+" or "-" offset, you will set this shunt in the appropriate position in Step 6).

J3 INPUT - INCOMING SIGNAL: Set in "E" position for voltage input. (If you require a current input, you will set this shunt in the "I" position AFTER you are finished with the calibration procedure).

Step 3) Wiring Connections

Make the following connections with the power OFF.

Connect a 24 volt AC or DC power supply to the ARM2 terminals "PWR" (+) and "PWR" (-).

Connect the input signal common (-) to the "SIG IN" (-) terminal. Connect (+) input signal lead to the "SIG IN" (+) terminal. To read input signal at ARM2 terminals connect (+) meter lead to the "SIG IN" (+) terminal and the (-) meter lead to the "SIG IN" (-) terminal (or in parallel). To read mA signal on either output, connect the meter in series with connections to the SIG1 and SIG2 output terminals. That is meter (+) to "SIG 1 or 2 OUT" (-) terminal and meter (-) to wire going to device being controlled.

Step 4) Power Up

Turn on the 24 volt power supply: the POWER indicator will light.

Step 5) Input/Output Signal Adjustments

In this step you will figure the desired voltage input signal span and the desired current output signal span (see the section on Equivalent Calibration Voltage) and calibrate the ARM2 to these input and output signal spans.

EQUIVALENT CALIBRATION VOLTAGE (Continued)

To calculate the voltage input signal span, subtract the minimum voltage input signal from the maximum input signal (i.e. a 0 to 5 volt input signal will give you a 5 volt input signal span: $5-0=5$).

To calculate the current output signal span, subtract the minimum output signal from the maximum output signal (i.e. a 4 to 20 mA output signal will give you a 16 mA output signal span: $20-4=16$).

Take the number for the voltage input signal span and apply this voltage to "IN" terminal.

Compare the output reading on your meter with the current output signal span you calculated above. If the meter reading is higher, adjust the "ATTN" trim pot until the meter reading drops to the calculated output span. If the meter reading is lower, adjust the "GAIN" trim pot until the meter reading increases to the calculated output signal span.

Step 6) Offset Adjustments

The offset adjustments simply shift the output signal range up or down from a "no offset" condition.

Example: An output signal range in a "no offset" condition is 8 to 16mA. Adding an offset of 4mA will now make the output signal range 4 to 12mA.

Apply the minimum voltage input signal and read the minimum output signal on the meter. With the "OFFSET" jumper shunt "J2" in the "O" position (from Step 6), no offset voltage will be added or subtracted from the output signal range.

If you need to shift the output signal range up, set the "OFFSET" jumper shunt "J2" in the "+" position and adjust the "OFFSET" trim pot until you increase the voltage reading on the meter to match the desired minimum output voltage. (Remember, this also increases the maximum output signal by the same amount).

If you need to shift the output signal range down, set the "OFFSET" jumper shunt "J2" in the "-" position and adjust the "OFFSET" trim pot until you decrease the voltage reading on the meter to match the desired minimum output voltage. (Remember, this also decreases the maximum output by the same amount.)

Step 7) Reverse Action Adjustments

If you will require your output signal to reverse act, set jumper shunt "J1" in the "R" position. Apply the minimum voltage input signal and adjust the "REV" trim pot for the highest desired output signal. Check the low, mid-scale and high signal points to insure proper calibration.

Step 8) Final Adjustments

If you require a current input, set the "J3" IN jumper shunt in the "I" position. Check operation of the ARM for desired signal re-scaling and operation.

PRODUCT SPECIFICATIONS

| NON-SPECIFIC INFORMATION | |
|--|--|
| Supply Voltage: | 22.8 to 30 VDC, 21.6 to 26.4 VAC |
| Supply Current: | 100 mA maximum |
| Input Voltage Signal Range (@ Impedance): | 0-35 VDC @ 1,000,000Ω |
| Input Current Signal Range (@ Impedance): | 0 to 44 mA @ 250Ω |
| Input Resistance Signal Range: | 0 to 500,000Ω |
| Field Adjustable Ranges: | Multi-turn potentiometers |
| Output Current Signal Range: | Signal Gain 1 to 20 times (nominal) depending on input value |
| Signal Output Accuracy: | Less than or equal to 1% of output span over full temperature range when using 1:1 input to output Accuracy is calibration dependent over full temperature range |
| Output Signal Attenuation: | 0 to 100% |
| Output Signal Offset: | 0.25 to 20 VDC |
| Output Signal Inversion (RA): | 20 to 0 mA (nominal) |
| Output Current Load Impedance: | 750Ω @ 20 mA |
| Regulated Power Output: | 23 VDC nominal @ 24 VAC Power Supply, 30 mA maximum |
| Connections: | 45° Captive screw Terminal Blocks |
| Wire Size: | 12 (3.31 mm ²) to 22 AWG (0.33 mm ²) |
| Terminal Block Torque Rating: | 0.5 Nm (Minimum); 0.6 Nm (Maximum) |
| Operating Temperature Range: | 35 to 120°F (1.7 to 48.9°C) |
| Operating Humidity Range: | 10 to 95% non-condensing |

WARRANTY

The ARM2 Series is covered by ACI's Two (2) Year Limited Warranty, which is located in the front of ACI'S SENSORS & TRANSMITTERS CATALOG or can be found on ACI's website: www.workaci.com.

W.E.E.E. DIRECTIVE

At the end of their useful life the packaging and product should be disposed of via a suitable recycling centre. Do not dispose of with household waste. Do not burn.



NOTES

NOTES



NOTES

NOTES



NOTES



Automation Components, Inc.

2305 Pleasant View Road

Middleton, WI 53562

Phone: 1-888-967-5224

Website: workaci.com

