



INTERFACE SERIES

Installation & Operation Instructions
EPC

Phone: 1-888-967-5224
Website: workaci.com

GENERAL INFORMATION

The EPC Series are electric to pneumatic transducers which convert an analog input signal to a proportional pneumatic output, modulating its control valve(s) to regulate the branch line pressure to the set point determined by the input signal. The EPC series offers four selectable input ranges. Output pressure ranges are jumper shunt selectable and adjustable in all ranges. A feedback signal indicating the resultant branch line pressure is also provided. EPC Series is designed with electrical terminals on one end and pneumatic connections on the other, allowing for maximum convenience in wiring and tubing installation when panel mounted. The EPC is a constant bleed interface with branch exhaust response time determined by the bleed orifice size and pressure differentials. If power fails to the EPC, it will continue to bleed through the bleed orifice until branch pressure is zero psig.

FIGURE 1: DIMENSIONS

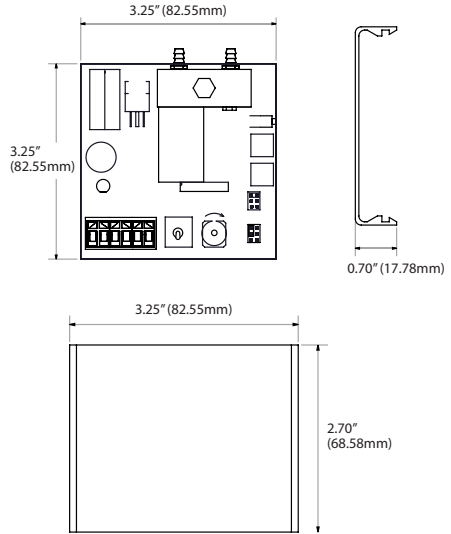

MOUNTING INSTRUCTIONS

Circuit board may be mounted in any position. If circuit board slides out of snap track, a non-conductive "stop" may be required. Use only fingers to remove board from snap track. Slide out of snap track or push against side of snap track and lift that side of the circuit board to remove. Do not flex board or use tools.

WIRING INSTRUCTIONS

PRECAUTIONS

- **Remove power before wiring. Never connect or disconnect wiring with power applied.**
- **When using a shielded cable, ground the shield only at the controller end. Grounding both ends can cause a ground loop.**
- **It is recommended you use an isolated UL-listed class 2 transformer when powering the unit with 24 VAC. Failure to wire the devices with the correct polarity when sharing transformers may result in damage to any device powered by the shared transformer.**
- **If the 24 VDC or 24VAC power is shared with devices that have coils such as relays, solenoids, or other inductors, each coil must have an MOV, DC/AC Transorb, Transient Voltage Suppressor (ACI Part: 142583), or diode placed across the coil or inductor. The cathode, or banded side of the DC Transorb or diode, connects to the positive side of the power supply. Without these snubbers, coils produce very large voltage spikes when de-energizing that can cause malfunction or destruction of electronic circuits.**
- **All wiring must comply with all local and National Electric Codes.**



FIGURE 2: WIRING

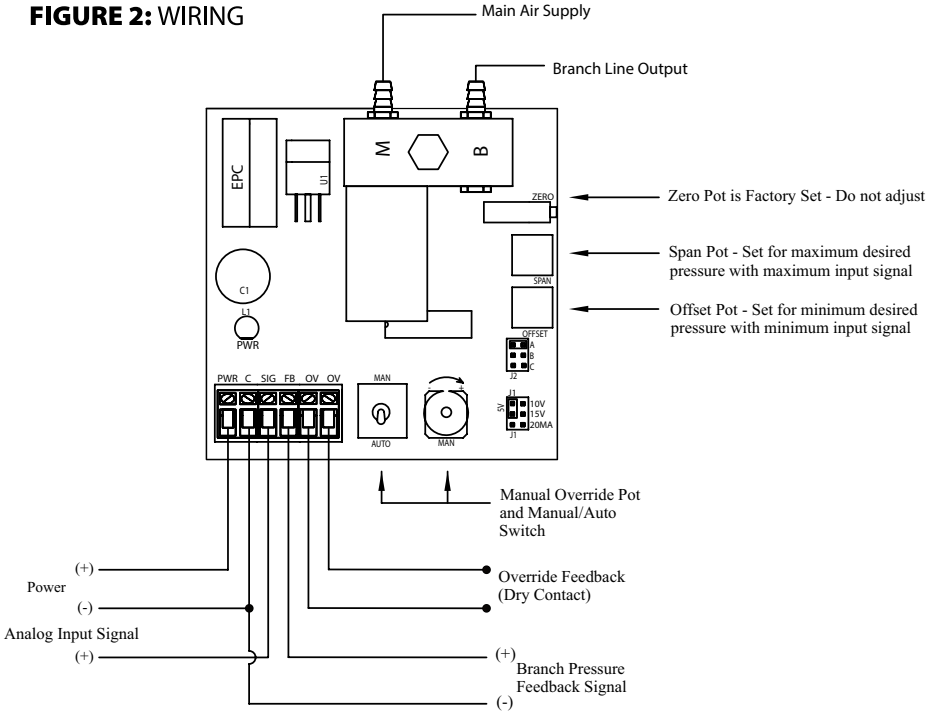

Pressure Output Range Selector

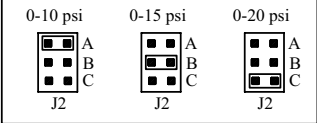

Signal Input Range Selector

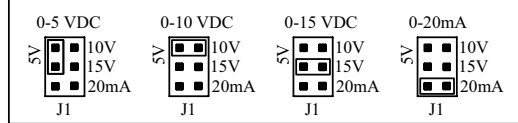
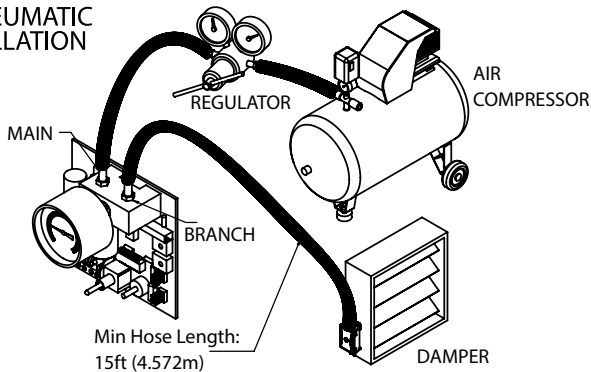

FIGURE 3: PNEUMATIC TUBING INSTALLATION



ADJUSTMENT OF GAUGES

If installation requires adjustment of the gauge for proper reading of the face, turn the gauge no more than ½ turn in either direction. O-rings in the bottom of the gauge port will allow this without leakage.

Warranty does not include malfunction due to clogged valve. Main air port on EPC is filtered with the supplied 80 – 100 micron integral-in-barb filter (Part # PN004). Periodically check the filter for contamination and flow reduction. Replace if needed (Part # PN004).

The surface between the manifold and pressure transducer is a pressure seal. Minimize stress between the circuit board and the manifold by holding the manifold in one hand while installing pneumatic tubing onto the fittings, and use care when removing tubing to avoid damaging fittings or moving manifold.

The bleed orifice can be unscrewed with a ¼" hex driver for cleaning or inspection. Do not lose the sealing gasket or insert anything into the precision bleed orifice. Clean by swabbing with a degreaser and blowing clean air through the orifice from the opposite direction.

This unit requires at least two cubic inches (minimum) of branch air line capacity (approx. 15 feet of ¼" O.D. polyethylene tubing) to operate without oscillation. Main air must be minimum of 2 psig above highest desired branch output pressure. Do not power without main air provided.

CHECKOUT

With power off, select one of the four input signal combinations by moving the jumper shunt J1 identified as "Input Signal Range Selector". Select a preset pressure output range by moving jumper shunt J2 identified as "Pressure Output Range Selector", or set custom range as described below.

SETTING CUSTOM OUTPUT PRESSURE RANGE

Verify the MAN/AUTO switch is in the AUTO position. In AUTO, the manual override pot is inactive, the override contacts are open, and the analog input signal is supplying the set-point. The offset pot may be adjusted to any desired offset between 0 and 14 psig. When in the MANUAL position, the override contacts are closed, the offset pot is inactive and the manual override pot is supplying the set point (the analog input signal is locked out). Supply power and the LED power indicator will light, but only measurement will verify proper voltage.

- 1. Setting the minimum pressure.** Make sure the signal connections are made and input is at minimum. Place the manual override switch to the AUTO position. Adjust the OFFSET pot to the desired pressure output, or until the actuator just starts to move. The adjustment range of the OFFSET pot is 0 to 9 psig (62.05 kPa), 0 to 14 psig (96.53 kPa), or 0 to 19 psig (131 kPa) depending on the range selected. Zero pot is factory set – DO NOT ADJUST.
- 2. Setting the maximum pressure.** Now place the manual override switch to the MANUAL position. Turn the MANUAL pot to produce the maximum branch line pressure available. Turn the SPAN pot for the maximum desired output pressure, or until the actuator just stops. Be sure the MAIN air pressure is at least 2 psig greater than the desired maximum branch output pressure.
- 3. Repeat.** Because the OFFSET and SPAN pots are slightly interactive, steps 1 and 2 must be repeated until the desired minimum and maximum pressures are repeatable. Since the MANUAL pot is set for maximum pressure, it is only required that you switch the manual override switch back and forth from MANUAL to AUTO when repeating steps 1 and 2. Calibration is usually accomplished in less than 3 iterations. Apply minimum and maximum input signals and measure response. Response between the minimum and maximum values will be linear, therefore software algorithms are easy to derive.

The feedback signal range on all selections is 0 to 5 VDC and is proportional to the output pressure range selected. The output and feedback signal will continue to vary proportionally if the input signal is increased

beyond its upper limit (if there is enough main air available).The EPC is a constant bleed interface and utilizes a precision bleed orifice to maintain a measured flow of air across the valve. The branch exhaust response time is determined by the combined exhaust air flow as well as pressure differentials. If power to the EPC is lost, it will continue to bleed through the orifice until branch pressure is 0 psig. To use the manual override, place the AUTO/MAN switch in the Man position. The potentiometer is now operable, and by turning the knob you may increase or decrease the pneumatic output.

PRODUCT SPECIFICATIONS

Supply Voltage:	24 VAC (+/-10%), 50 or 60Hz, 24 VDC (+10%/- 5%)
Supply Current:	500mAAC, 200mADC Maximum
Input Signal Source (@ Impedance):	0-5 VDC @ infinite Ω 0-10 VDC @ infinite Ω 0-15 VDC @ infinite Ω 0-20 mA / 250 Ω
Feedback Signal Output Range:	0-5 VDC = Output Span
Output Pressure Range:	Field Calibration Possible: 0 to 20 psig (0-138 kPa) maximum
Output Pressure Range-Jumper Selectable:	0-10 psig (0-68.95 kPa), 0-15 psig (0-103.43 kPa) or 0-20 psig (137.9 kPa)
Air Supply Pressure:	Maximum 25 psig (172.369 kPa), minimum 22 psig (151.69 kPa)
Air Consumption:	2300 SCIM (37.69 Liters)
Manual / Auto Override Switch:	MAN function = output can be varied AUTO function = output is controlled from input signal
Manual / Auto Override Feedback Output:	Dry Contacts: 24 VDC/VAC @ 1A maximum, N.O. in AUTO operation (Optional: N.O. in MAN operation)
Air Flow:	Supply valves @ 25 psig (172.38 kPa) main/20 psig (137.9 kPa) out, 2300 scim Branch Line requires 2 in3 / 33.78 cm3 (min.) Min. 15 ft of 1/4" O.D. poly branch tubing
Filtering:	Furnished with integral-in-barb 80-100 micron filter (Part # PN004)
Connections Wire Size:	90° Pluggable Screw Terminal Blocks 16 (1.31 mm2) to 26 AWG (0.129 mm2)
Terminal Block Torque Rating:	0.5 Nm (Minimum); 0.6 Nm (Maximum)
Connections Pneumatic Tubing Size-Type:	1/4" O.D. nominal (1/8" I.D.) polyethylene
Pneumatic Fitting:	Removeable brass fittings for Main & Branch in machined manifold, Plugged 1/8-27-FNPT gauge port
Operating Temperature Range:	35 to 120°F (1.7 to 48.9°C)
Operating Humidity Range:	10 to 95% non-condensing
Storage Temperature:	-20 to 150°F (-28.9 to 65.5°C)

WARRANTY

The EPC Series is covered by ACI's Two (2) Year Limited Warranty, which is located in the front of ACI'S SENSORS & TRANSMITTERS CATALOG or can be found on ACI's web site: www.workaci.com.

