



TO Series

Outdoor Temperature Sensor

Product Overview

The TO sensor has a weather-resistant housing suitable for monitoring outdoor temperature. The probe is protected from solar heating to improve accuracy. The TO has standard resistive output compatible with building control systems, and it is warranted for a period of five years.



NOTICE

- This product is not intended for life or safety applications.
- Do not install this product in hazardous or classified locations.
- Read and understand the instructions before installing this product.
- Turn off all power supplying equipment before working on it.
- The installer is responsible for conformance to all applicable codes.

If this product is used in a manner not specified by the manufacturer, the protection provided by the product may be impaired. No responsibility is assumed by the manufacturer for any consequences arising out of the use of this material.

Product Identification

<p>TO</p> <p>Sensor Type</p> <div style="border: 1px solid black; width: 20px; height: 20px; margin: 0 auto;"></div> <p>B = 100R platinum, RTD C = 1k platinum, RTD D = 10k T2, Thermistor E = 2.2k, Thermistor F = 3k, Thermistor H = 10k T3, Thermistor I = 1k Balco (Nickel-iron) RTD J = 10k Dale, Thermistor K = 10k w/11k shunt, Thermistor M = 20k NTC, Thermistor N = 1800 ohm, Thermistor W = 10k T2 high accuracy, Thermistor Y = 10k T3 high accuracy, Thermistor</p>	<p>Output</p> <div style="border: 1px solid black; padding: 2px; display: inline-block;">RØ</div> <p>= Resistive</p>	<p>Cal Certificate</p> <div style="border: 1px solid black; width: 20px; height: 20px; margin: 0 auto;"></div> <p>0 = None 2 = 3-point NIST calibration</p>
--	---	---

Specifications

Wiring	22 AWG; 2-wire RTD/Thermistor
Housing	Weatherproof
Mounting Location	For outdoor use
COMPLIANCE INFORMATION	
Approvals	CE

Dimensions

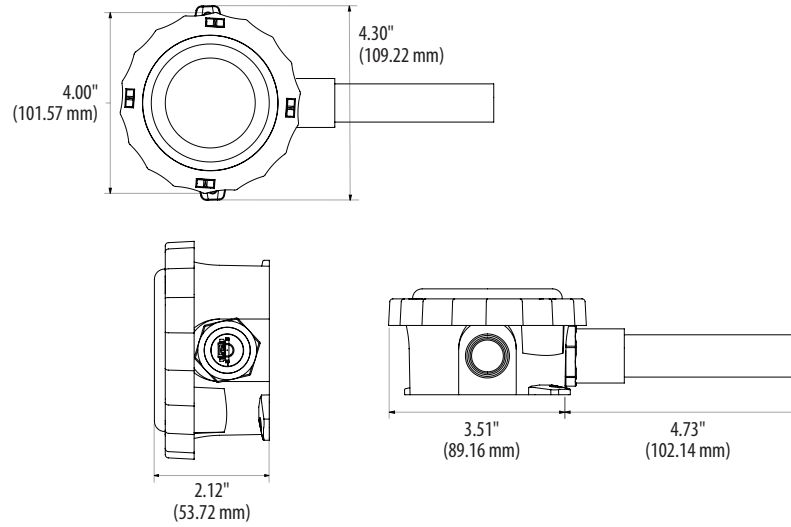

Installation

1. Choose a monitoring location that is sheltered and out of direct sunlight (e.g. under eaves, north side of building, etc.).
2. Connect the wires as shown.

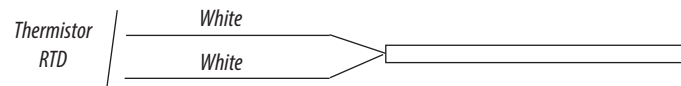

3. The sensor may be suspended from the conduit without damage to the unit. Do not obstruct the vent openings.